



YAMAHA

PARTS LIST



零件手冊

YP125D/C/A(5CA4/7/8)

※本圖僅供參考，顏色等以實車為準※

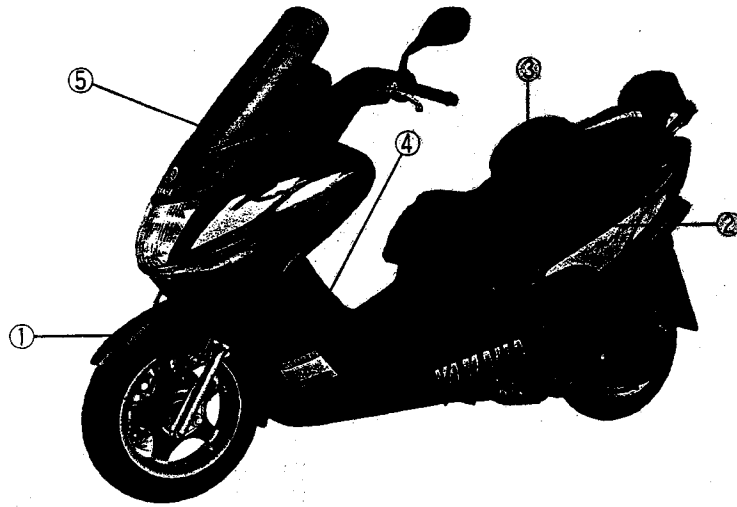

YP125D(5CA4)藍車

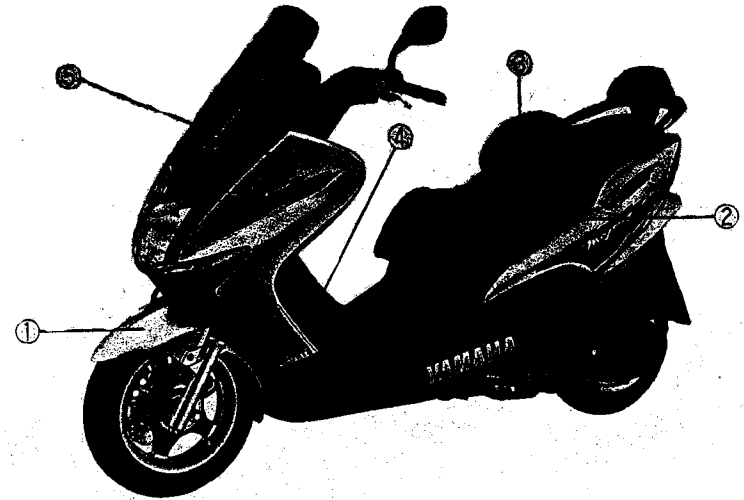

YP125D(5CA4)銀車

項次	部品番號	部品名稱	項次	部品番號	部品名稱
1.	5CA-F1511-01-P7	前擋泥蓋	1.	5CA-F1511-01-1V	前擋泥蓋
2.	5CA-X2171-00-P7	側蓋1	2.	5CA-X2171-20-1V	側蓋1
	5CA-X2172-00-P7	側蓋2		5CA-X2172-20-1V	側蓋2
3.	5CA-F4730-00	雙人座墊	3.	5CA-F4730-00	雙人座墊
4.	5CA-F8311-00	腳防護板1	4.	5CA-F8311-00	腳防護板1
5.	5CA-X283U-00-2X	前蓋1	5.	5CA-X283U-00-3X	前蓋1
	5CA-X283V-00-2X	前蓋2		5CA-X283V-00-3X	前蓋2

※本圖僅供參考，顏色等以實車為準※

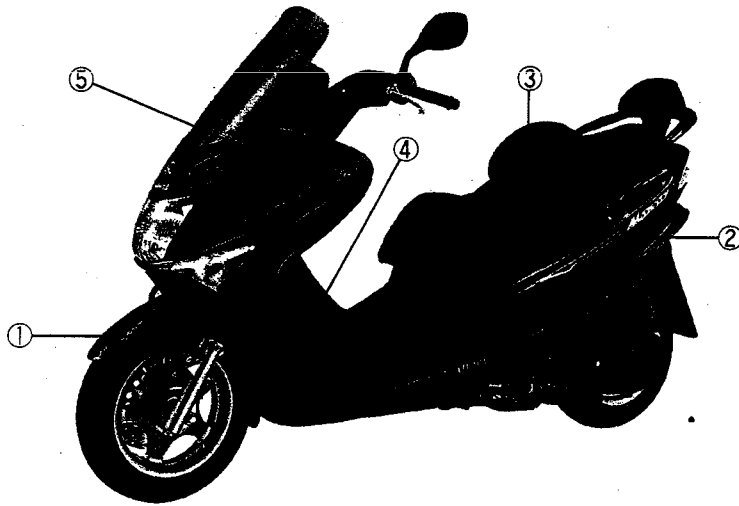

YP125A(5CA8)黑車

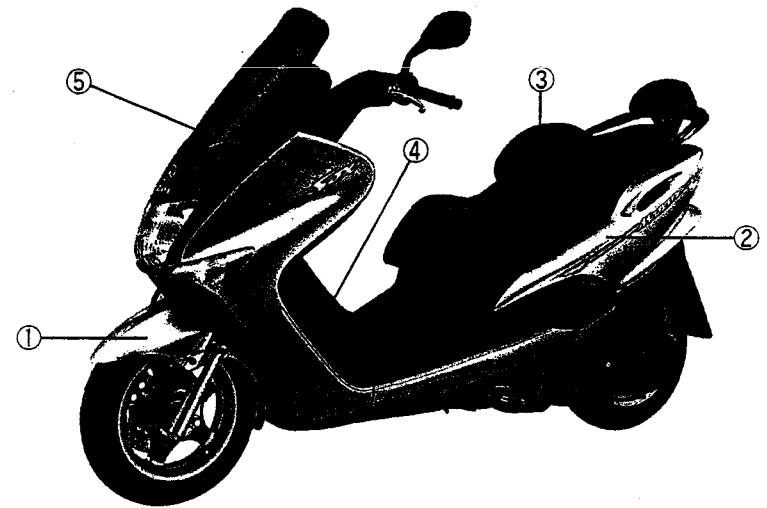

YP125A(5CA8)銀車

項次	部品番號	部品名稱
1.	5CA-F1511-01-4B	前擋泥蓋
2.	5CA-X2171-20-4B	側蓋1
	5CA-X2172-20-4B	側蓋2
3.	5CA-F4730-00	雙人座墊
4.	5CA-F8311-00	腳防護板1
5.	5CA-X283U-20-4B	前蓋1
	5CA-X283V-20-4B	前蓋2

項次	部品番號	部品名稱
1.	5CA-F1511-01-1V	前擋泥蓋
2.	5CA-X2171-40-1V	側蓋1
	5CA-X2172-40-1V	側蓋2
3.	5CA-F4730-00	雙人座墊
4.	5CA-F8311-00	腳防護板1
5.	5CA-X283U-10-1V	前蓋1
	5CA-X283V-10-1V	前蓋2

※本圖僅供參考，顏色等以實車為準※

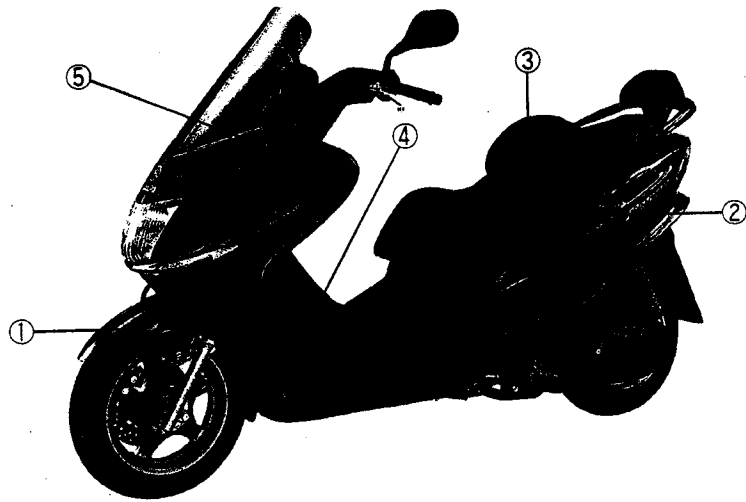

YP125C(5CA7)深綠車

項次	部品番號	部品名稱
1.	5CA-F1511-01-P4	前擋泥蓋
2.	5CA-X2171-30-P4	側蓋1
	5CA-X2172-30-P4	側蓋2
3.	5CA-F4730-00	雙人座墊
4.	5CA-F8311-00	腳防護板1
5.	5CA-F835U-00-P4	前蓋1
	5CA-F835V-00-P4	前蓋2

※本圖僅供參考，顏色等以實車為準※

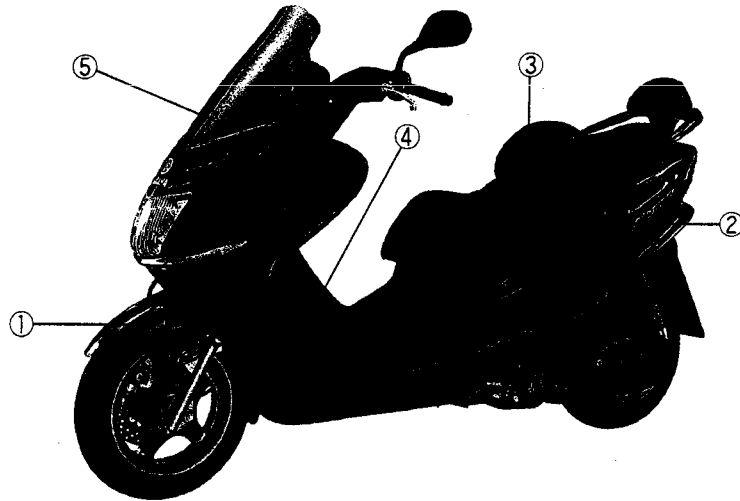

YP125C(5CA7)黑車

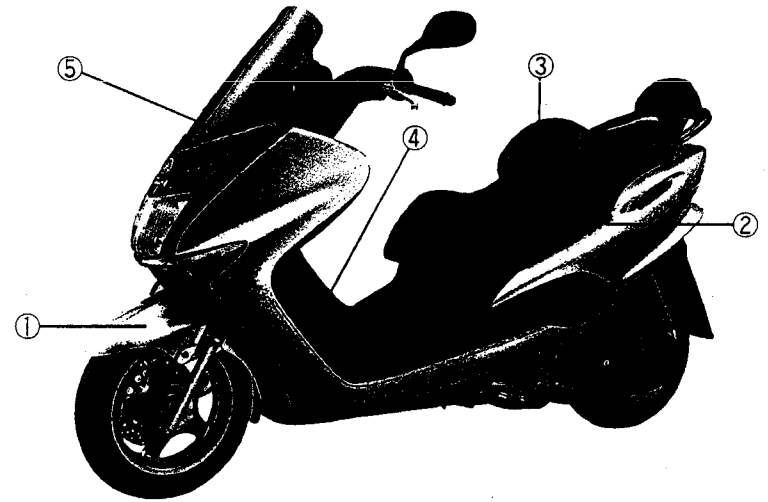

YP125C(5CA7)銀車

項次	部品番號	部品名稱	項次	部品番號	部品名稱
1.	5CA-F1511-01-P6	前擋泥蓋	1.	5CA-F1511-01-1V	前擋泥蓋
2.	5CA-X2171-00-P6	側蓋1	2.	5CA-X2171-30-1V	側蓋1
	5CA-X2172-00-P6	側蓋2		5CA-X2172-30-1V	側蓋2
3.	5CA-F4730-00	雙人座墊	3.	5CA-F4730-00	雙人座墊
4.	5CA-F8311-00	腳防護板1	4.	5CA-F8311-00	腳防護板1
5.	5CA-F835U-00-P6	前蓋1	5.	5CA-F835U-00-1V	前蓋1
	5CA-F835V-00-P6	前蓋2		5CA-F835V-00-1V	前蓋2

序 言

這本零件手冊適用於 YAMAHA YP125(5CA4/7/8)的機種，當您要訂購 YAMAHA YP125(5CA4/7/8)之零件時，請參考這本零件手冊，並正確的引用部品番號和部品名稱。

一、 在本零件手冊發行後，若有修改、增訂或價格調整時，將會發佈部品通報，關於部品通報，請您必須及時的依通報更正您手中的零件手冊，以保持準確度。

二、 縮寫：

下列是使用在本零件手冊內的縮寫代號

U.R. 依需要使用尺寸（厚度）及／或數 V. 燈泡伏特

U.N. 依實際需要而訂 W. 燈泡瓦特

T. 齒數 L.M. 台灣製造

三、 以組立總成形態供銷之零件，在零件名稱前空一個字母之空間，在此空間印有一個“.”字號來表示。

四、 組立總成構成零件數之指示，登載在每一個構成零件右邊之用量欄內。是每一獨立組立總成單位中之數量。

(例) 部品番號 英文名稱 中文名稱 用量 備註

3XG-X8575-00 SENDER UNIT ASSY 汽油油面感應器 1

53X-H5753-00 .GASKET, sender unit 墊片 1

五、 引擎編號及色彩種類

型式	顏色	引擎編號
5CA4-A	藍	5CA-400101 ~
5CA4-B	銀	5CA-400101 ~
5CA7-A	黑	5CA-700101 ~
5CA7-B	銀	5CA-700101 ~
5CA7-C	深綠	5CA-700101 ~
5CA8-A	黑	5CA-800101 ~
5CA8-B	銀	5CA-800101 ~

六、 圖案色彩之選購：在註記欄內寫出選用之色彩全名

(例) 部品番號	英文名稱	中文名稱	用量	備註
3XG-X2151-00-0X	FENDER, front	前擋泥蓋	1	用於白／藍車
3XG-X2151-00-1X	FENDER, front	前擋泥蓋	1	用於黑／紫車

七、 細小之零件以本公司之最小販賣單位為購買單位(價格另以單位價計)。

八、 本冊內所列價格，是建議零售價格，如遇成本變動，將做適度之調整。

九、 價格之異動以本公司通知書類為準

目錄

引擎部品

Fig 1	汽缸頭	2
Fig 2	曲軸	6
Fig 3	閘門	8
Fig 4	冷卻泵浦	12
Fig 5	散熱裝置	14
Fig 6	潤滑油泵	18
Fig 7	空氣吸入口	20
Fig 8	化油器	24
Fig 9	排氣裝置	28
Fig 10	曲軸箱	34
Fig 11	起動機構	42
Fig 12	離合器	46
Fig 13	傳動機構	50

車體部品

Fig 14	車架	52
Fig 15	前擋泥蓋	54
Fig 16	前擋泥蓋	56
Fig 17	前擋泥蓋	58
Fig 18	側蓋	60
Fig 19	側蓋	64
Fig 20	側蓋	68
Fig 21	後臂，懸吊系統	72
Fig 22	前叉	74
Fig 23	汽油箱	80
Fig 24	座墊	84
Fig 25	前輪	90
Fig 26	前剎車卡鉗	92
Fig 27	後輪	94

Fig 28	轉向把手，鋼索	96
Fig 29	前主缸	100
Fig 30	支架，置腳踏	102
Fig 31	支架，置腳踏	106
Fig 32	支架，置腳踏	110
Fig 33	腳防護板	114
Fig 34	腳防護板	120
Fig 35	腳防護板	126

電裝部品

Fig 36	發電機	132
Fig 37	起動馬達	134
Fig 38	方向燈	136
Fig 39	計量表	138
Fig 40	前燈	140
Fig 41	後燈	142
Fig 42	把手開關，把手	144
Fig 43	電裝1	148

索引

部品番號索引	153
--------	-----

FIG. 1 汽缸頭 2

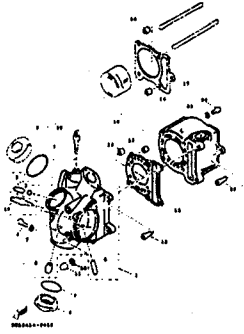

FIG. 2 曲軸 6

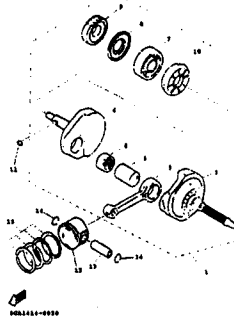

FIG. 3 閥門 8

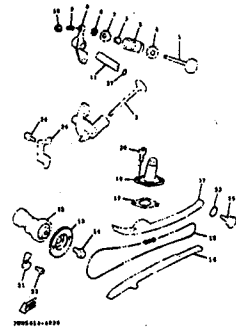

FIG. 4 冷卻泵浦 12

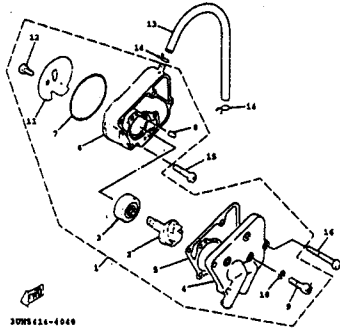

FIG. 5 散熱裝置 14

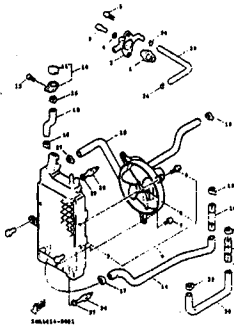

FIG. 6 潤滑油泵 18

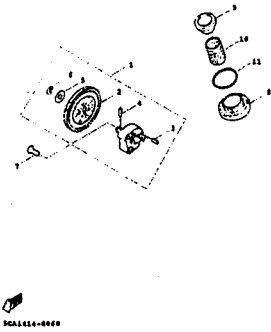

FIG. 7 空氣吸入口 20

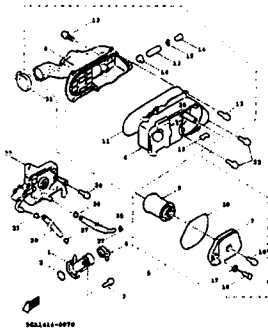

FIG. 8 化油器 24

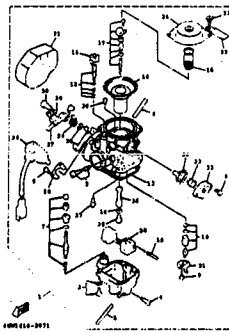

FIG. 9 排氣裝置 28

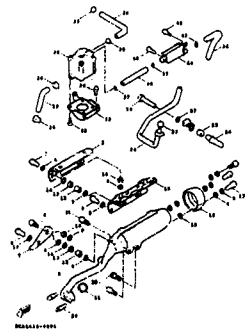

FIG. 10 曲軸箱 34

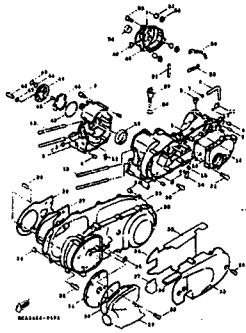

FIG. 11 起動機構 42

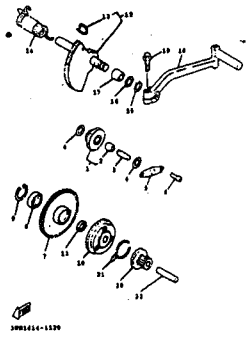

FIG. 12 離合器 46

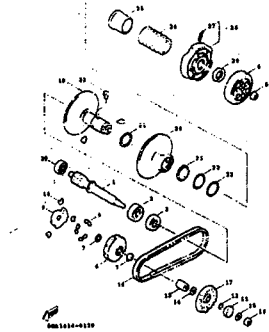

FIG. 13 傳動機構 50

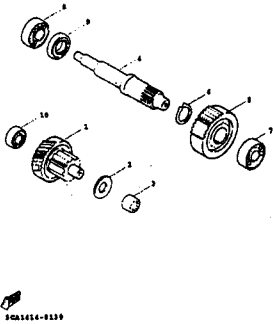

FIG. 14 車架 52

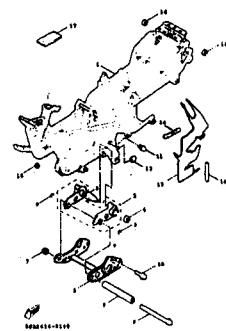

FIG. 15 擋泥蓋 54

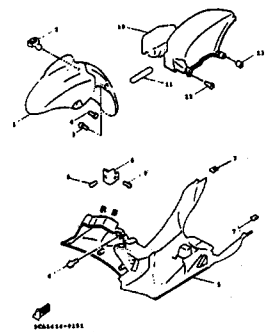

FIG. 16 前擋泥蓋 56

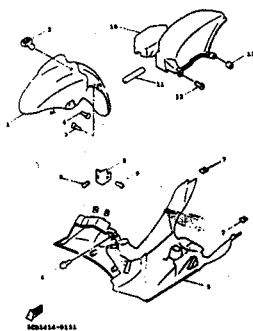

FIG. 17 擋泥蓋後架 58

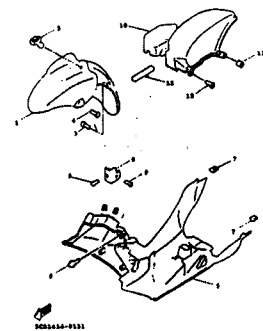

FIG. 18 側蓋 60

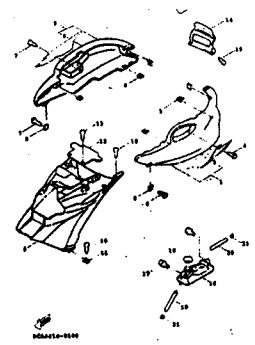

FIG. 19 潤滑油箱 64

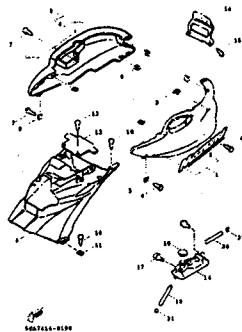

FIG. 20 側蓋潤滑油箱 68

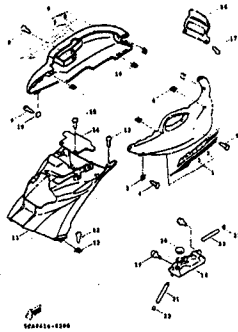

FIG. 21 後臂，懸吊系統 72

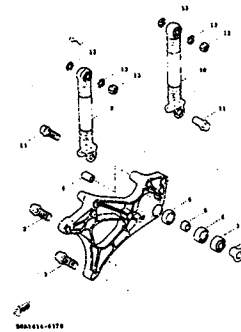

FIG. 22 前叉 74

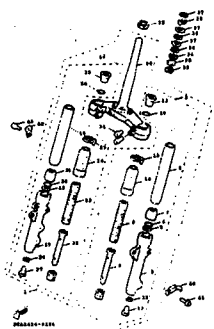

FIG. 23 汽油箱 80

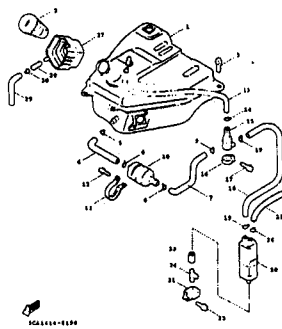

FIG. 24 座墊 84

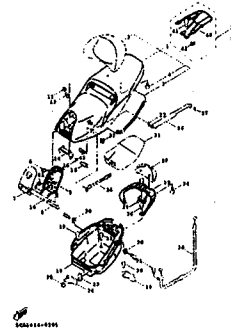

FIG. 25 前輪 90

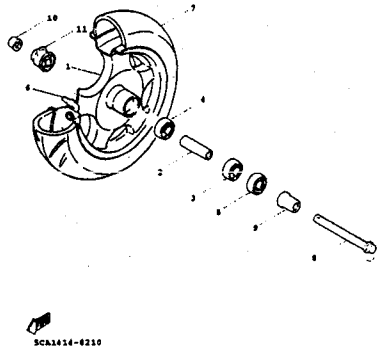

FIG. 26 前剎車卡鉗 92

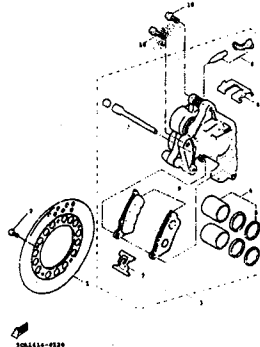

FIG. 27 後輪 94

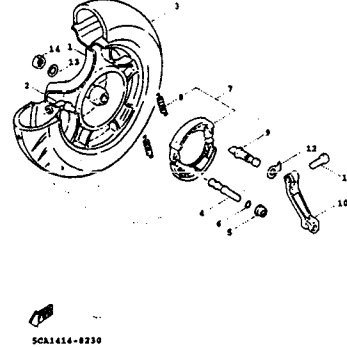

FIG. 28 轉向把手, 鋼索 96

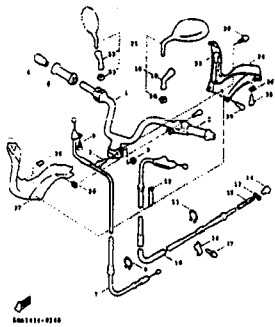

FIG. 29 前主缸 100

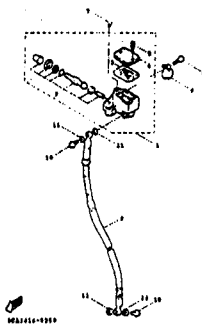

FIG. 30 支架 102

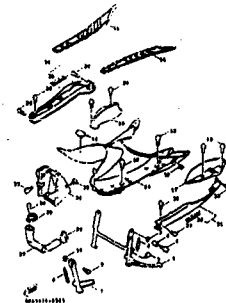

FIG. 31 支架, 置腳踏 106

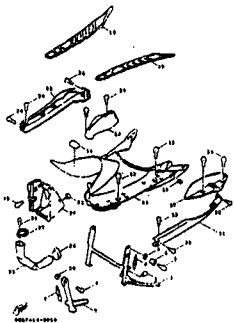

FIG. 32 後主缸 110

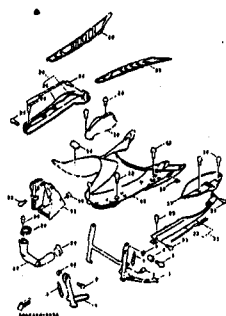

FIG. 33 腳防護板 114

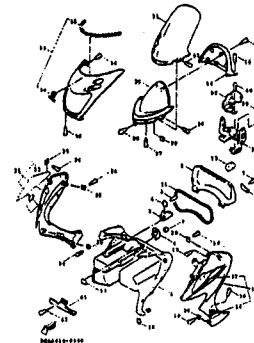

FIG. 34 腳防護板 120

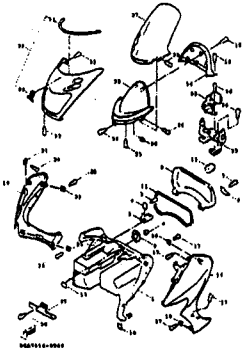

FIG. 35 腳防護板 126

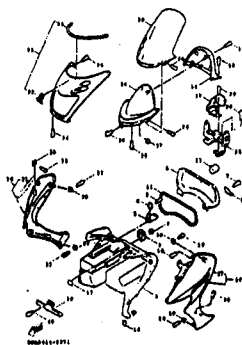

FIG. 36 發電機 132

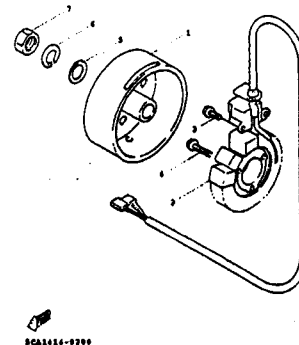
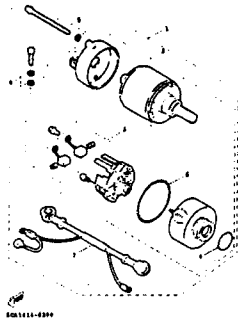
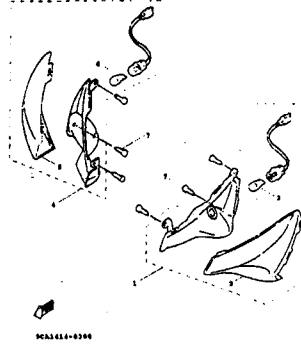

FIG. 37 起動馬達 134



SCA1414-0304

FIG. 38 方向燈 136



SCA1414-0306

FIG. 39 計量表 138

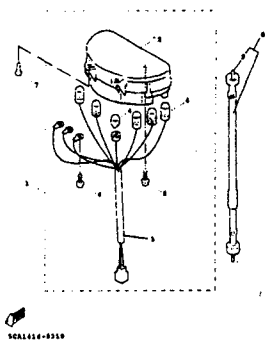

SCA1414-0310

FIG. 40 前燈 140

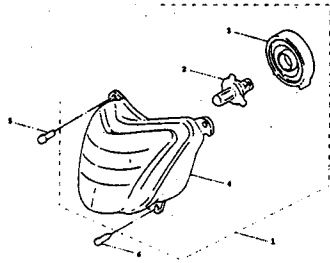

SCA1414-0321

FIG. 41 後燈 142

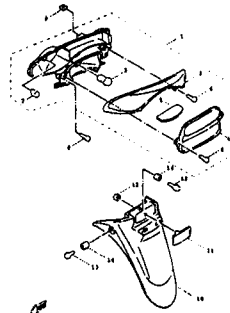

SCA1414-0320

FIG. 42 把手開關，把手 144

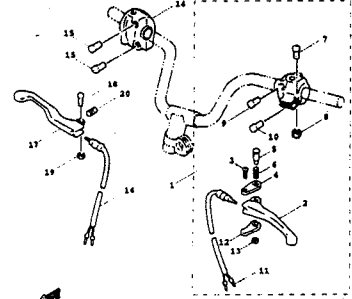

SCA1414-0303

FIG. 43 電裝1 148

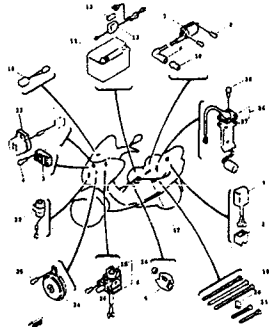

SCA1414-0325

FIG.

FIG.

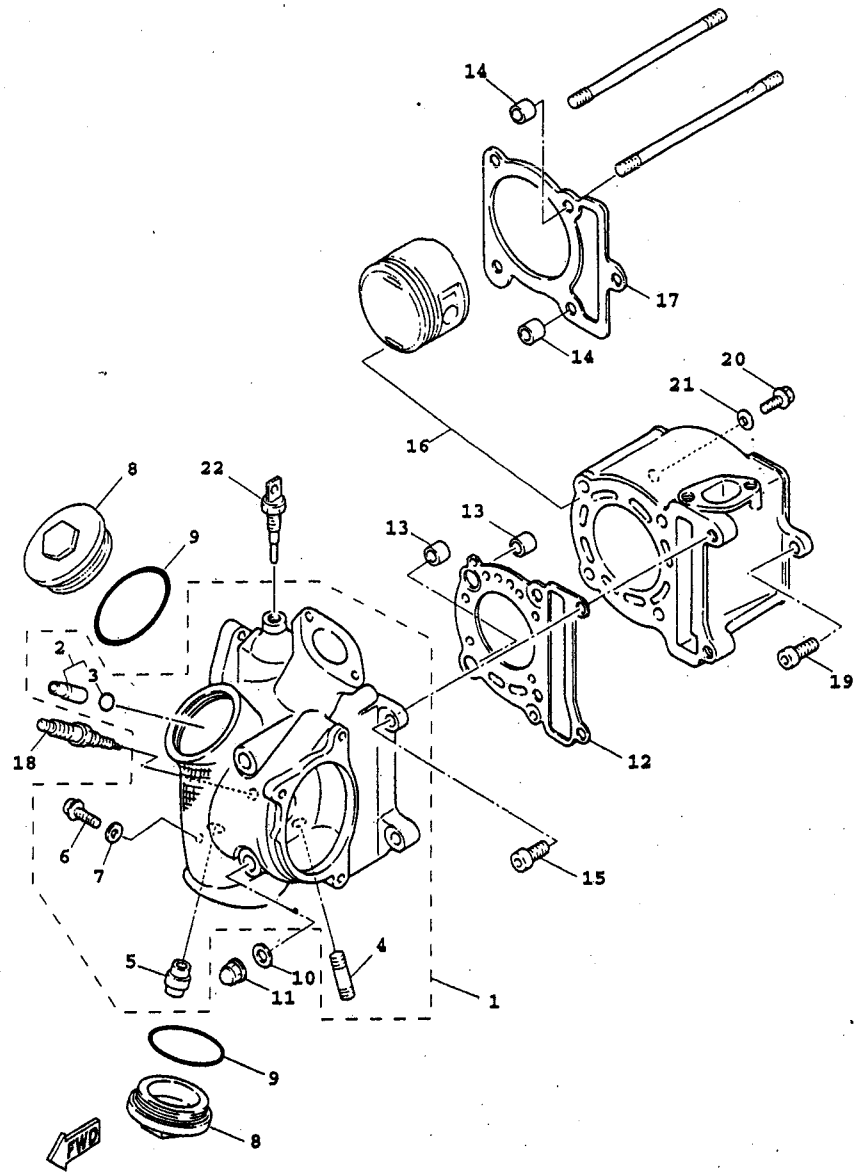

5CA1414-8010

FIG. 1 汽缸頭

項次	部品番號	英文名稱	中文名稱	用量	建議價格	備註	代碼	工時
1	5CA-E1102-00	CYLINDER HEAD ASSY	汽缸頭總成	1	3,200			
2	3UH-W1136-10	.INTAKE VALVE GUIDE SET	進氣閥導件組	2	450			
3	93440-10153	..CIRCLIP	夾環	1	5			
4	3UH-E4651-00	.BOLT	螺栓	2	5			
5	3UH-E4871-10	.PIPE 1	油管	1	90			
6	90153-06803	.SCREW, HEXAGON	六角十字螺絲	1	3			
7	90430-06014	.GASKET	墊片	1	5			
8	3KW-E1186-00	COVER, CYLINDER HEAD SIDE 2	汽缸頭側蓋	2	28			
9	93210-448C2	O-RING	護油圈	2	8			
10	90201-08609	WASHER, PLATE	平墊圈	4	5			
11	90176-08816	NUT, CROWN	有蓋螺帽	4	5			
12	5DS-11181-00	GASKET, CYLINDER HEAD 1	汽缸蓋墊片	1	300			
13	99530-10114	PIN, DOWEL	定位銷	2	10			
14	99530-10114	PIN, DOWEL	定位銷	2	10			
15	91317-06025	BOLT, HEX. SOCKET	六角套頭螺栓	2	5			
16	5CA-Y1310-00	CYLINDER PISTON SET	汽缸組	1	2,000			
17	5CA-E1351-00	GASKET, CYLINDER	汽缸墊片	1	20			
18	94700-00826	PLUG, SPARK	火星塞	1	180			
19	91317-06025	BOLT, HEX. SOCKET	六角套頭螺栓	1	5			

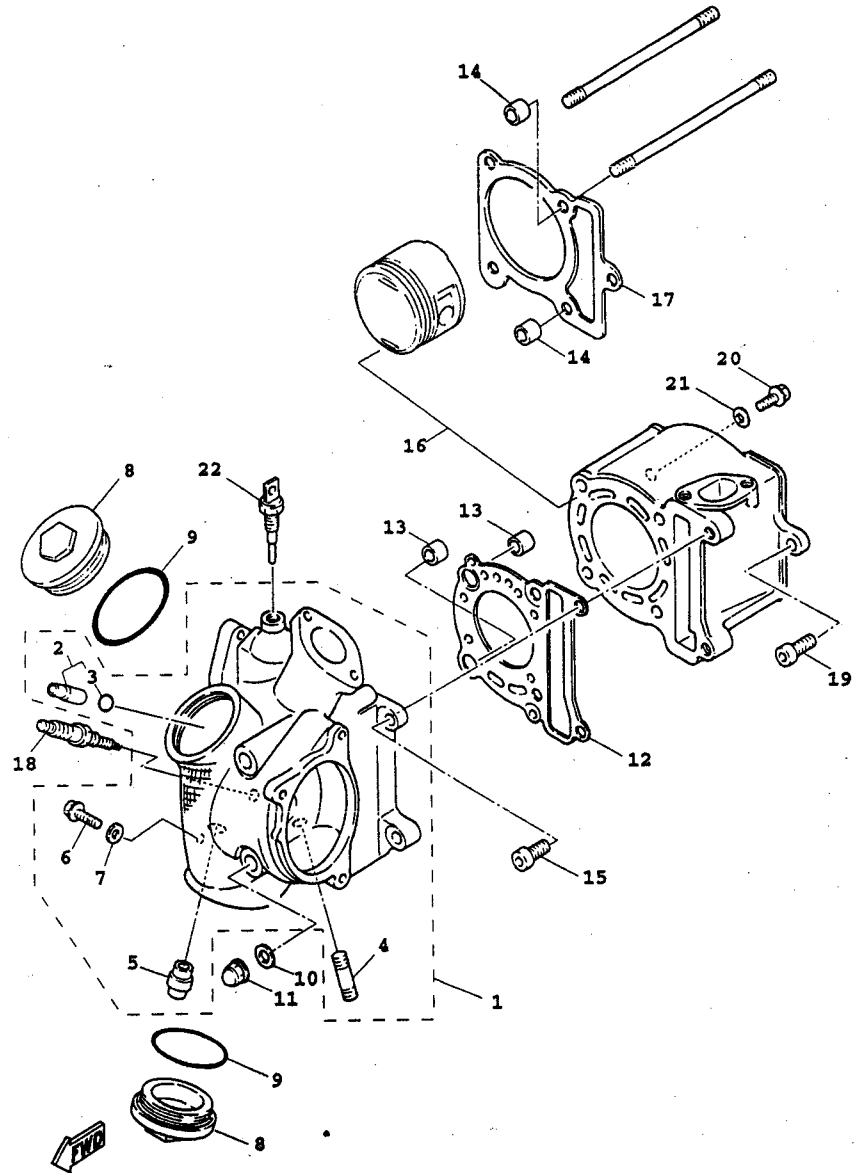

5CA1414-8010

FIG. 1 汽缸頭

項次	部品番號	英文名稱	中文名稱	用量	建議價格	備註	代碼	工時
20	95027-06010	BOLT, FLG	凸緣螺栓	1	5			
21	90430-06014	GASKET	墊片	1	5			
22	4BA-82560-00	THERMO SWITCH ASSY	感溫器	1	1,200			

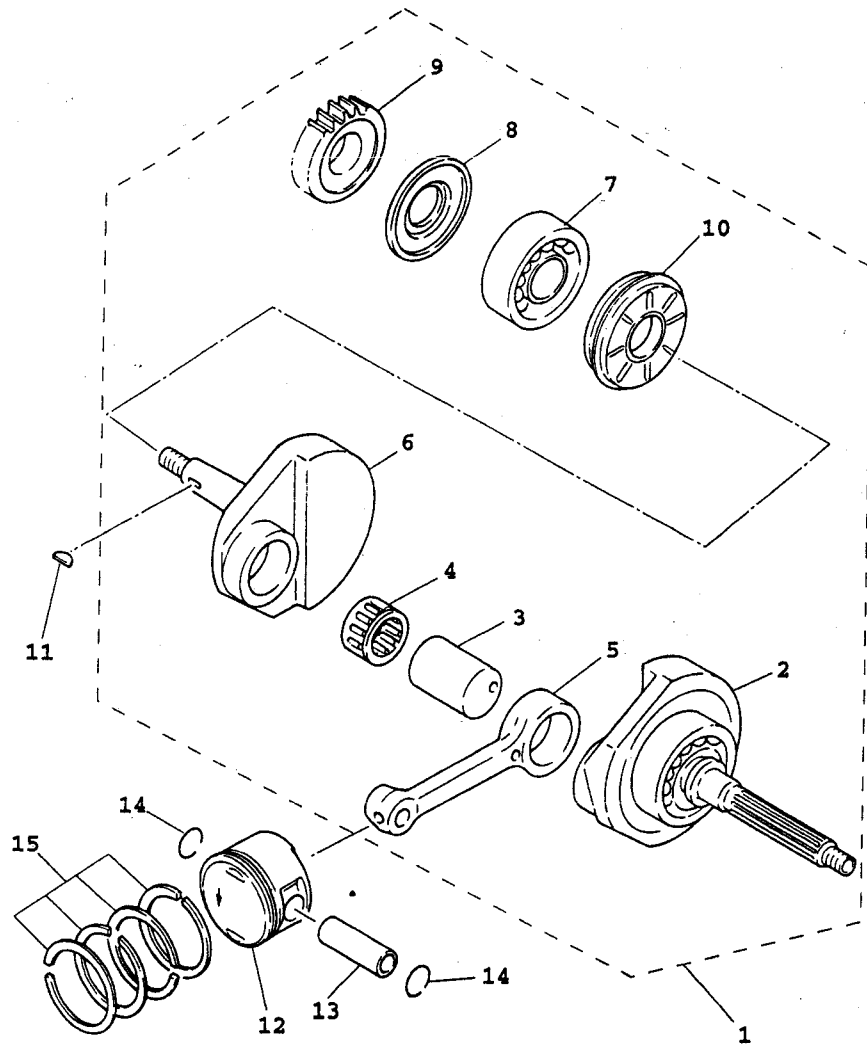

5CA1414-8020

FIG. 2 曲軸

項次	部品番號	英文名稱	中文名稱	用量	建議價格	備註	代碼	工時
1	5CA-E1400-00	CRANKSHAFT ASSY	曲軸總成	1	2,500			
2	5CA-W1141-00	.CRANK KIT	曲軸組	1	850			
3	5CA-E1681-00	.PIN, CRANK 1	曲軸銷	1	105			
4	93310-6290C	.BRG.	軸承	1	300			
5	5CA-E1651-00	.ROD, CONNECTING	連桿	1	200			
6	5CA-E1422-00	.CRANK 2	右曲軸	1	600			
7	93306-30536	.BEARING (B6305C3)	軸承	1	445			
8	3UH-E1445-00	.SPACER	隔筒	1	20			
9	3UH-E3324-00	.GEAR, PUMP DRIVE	驅動齒輪	1	135			
10	5CA-E3451-00	.FILTER, ROTARY	過濾器	1	140			
11	90280-03017	KEY, WOODRUFF	半圓鍵	1	13			
12	5CA-E1631-00	PISTON(STD)	活塞(STD)	1	300			
13	3UH-E1633-00	PIN, PISTON	活塞銷	1	45			
14	93450-16068	CIRCLIP	夾環	2	3			
15	5CA-E1603-00	PISTON RING SET (STD)	活塞環組(STD)	1	250			

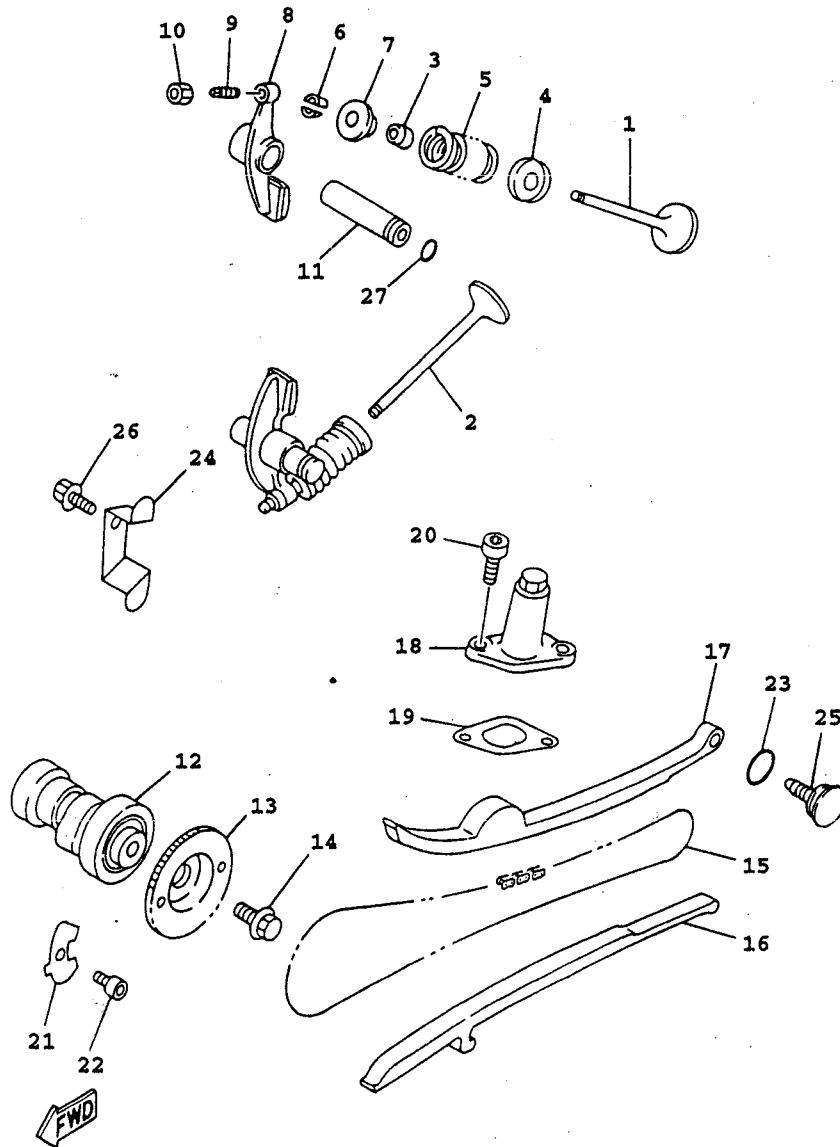

3UH5414-4030

FIG. 3 閥門

項次	部品番號	英文名稱	中文名稱	用量	建議價格	備註	代碼	工時
1	3UH-E2111-01	VALVE, INTAKE	進氣閥	1	113			
2	3UH-E2121-00	VALVE, EXHAUST	排氣閥	1	223			
3	4TE-12119-00	SEAL, VALVE STEM	氣門桿油封	2	55			
4	1WG-12116-00	SEAT, VALVE SPRING	閥門彈簧座	2	50			
5	1WG-12113-01	SPRING, VALVE INNER	彈簧	2	100			
6	1WG-12118-00	COTTER, VALVE	閥門銷	4	12			
7	3UH-12117-00	RETAINER, VALVE SPRING	閥門彈簧鎖扣	2	60			
8	3UH-12151-00	ARM, VALVE ROCKER	閥門搖臂	2	600			
9	22F-12159-00	SCREW, VALVE ADJUSTING	閥門調節螺絲	2	60			
10	90170-05302	NUT	六角螺帽	2	7			
11	3UH-E2156-00	SHAFT, ROCKER 2	搖臂軸	2	34			
12	5CA-E2170-01	CAMSHAFT ASSY 1	凸輪軸總成	1	1,100			
13	3UH-E2176-00	SPROCKET, CAM CHAIN	鏈輪	1	148			
14	90105-08825	BOLT, WASHER BASED	墊圈座帽螺栓	1	7			
15	94591-48094	CHAIN	鏈條	1	650			
16	5CA-E2231-00	GUIDE, STOPPER 1	停止器導件	1	50			
17	5CA-E2241-00	GUIDE, STOPPER 2	停止器導件	1	50			
18	4CW-E2210-01	TENSIONER ASSY, CAM CHAIN	鏈條張力器	1	215			
19	4DH-E2213-01	GASKET, TENSIONER CASE	張力器墊片	1	10			

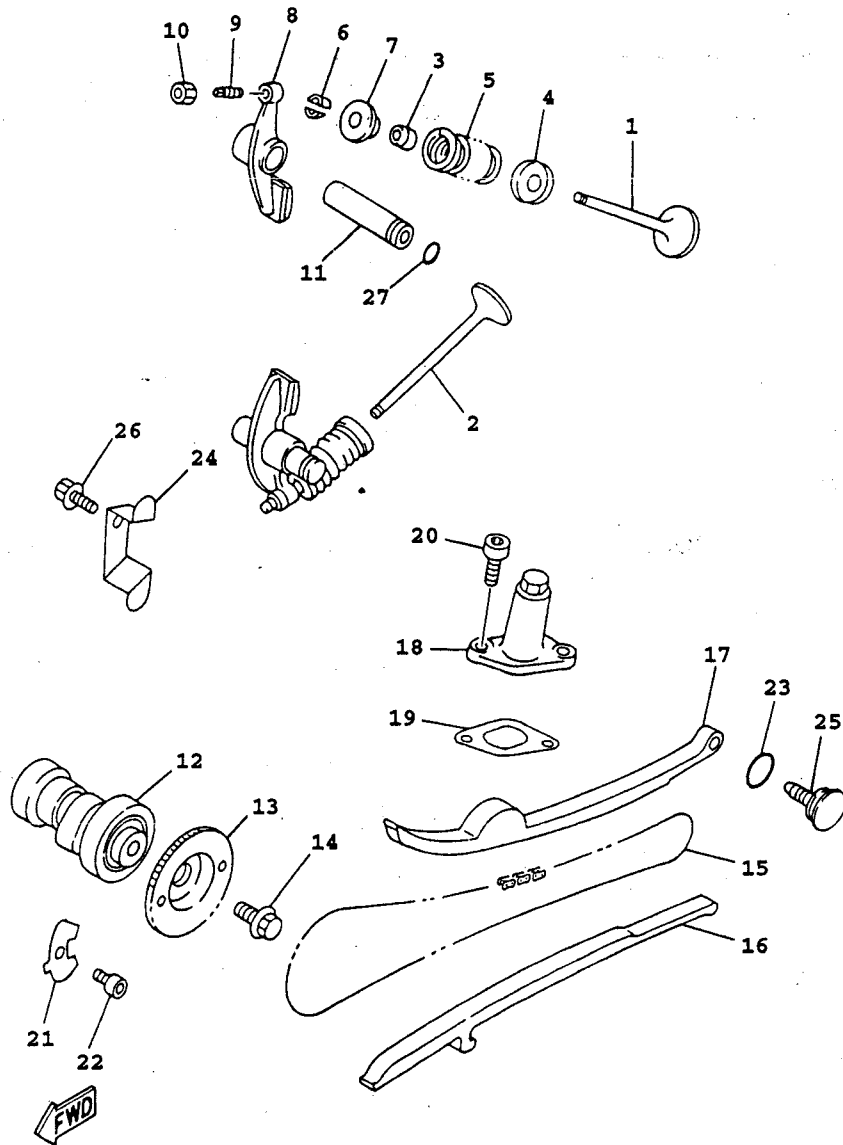

3UH5414-4030

FIG. 3 閥門

項次	部品番號	英文名稱	中文名稱	用量	建議價格	備註	代碼	工時
20	91317-06014	BOLT, HEX. SOCKET	六角套頭螺栓	2	5			
21	3UH-E111F-00	PLATE	板	1	5			
22	91317-06012	BOLT, HEX. SOCKET	六角套頭螺栓	1	3			
23	93210-15862	O-RING	護油圈	1	5			
24	5CA-E2279-00	PLATE	板	1	10			
25	4CW-E2157-00	NUT, LOCK	螺栓	1	10			
26	95827-06012	BOLT.FLG	凸緣螺栓	1	3			
27	93210-09884	O-RING	護油圈	2	5			

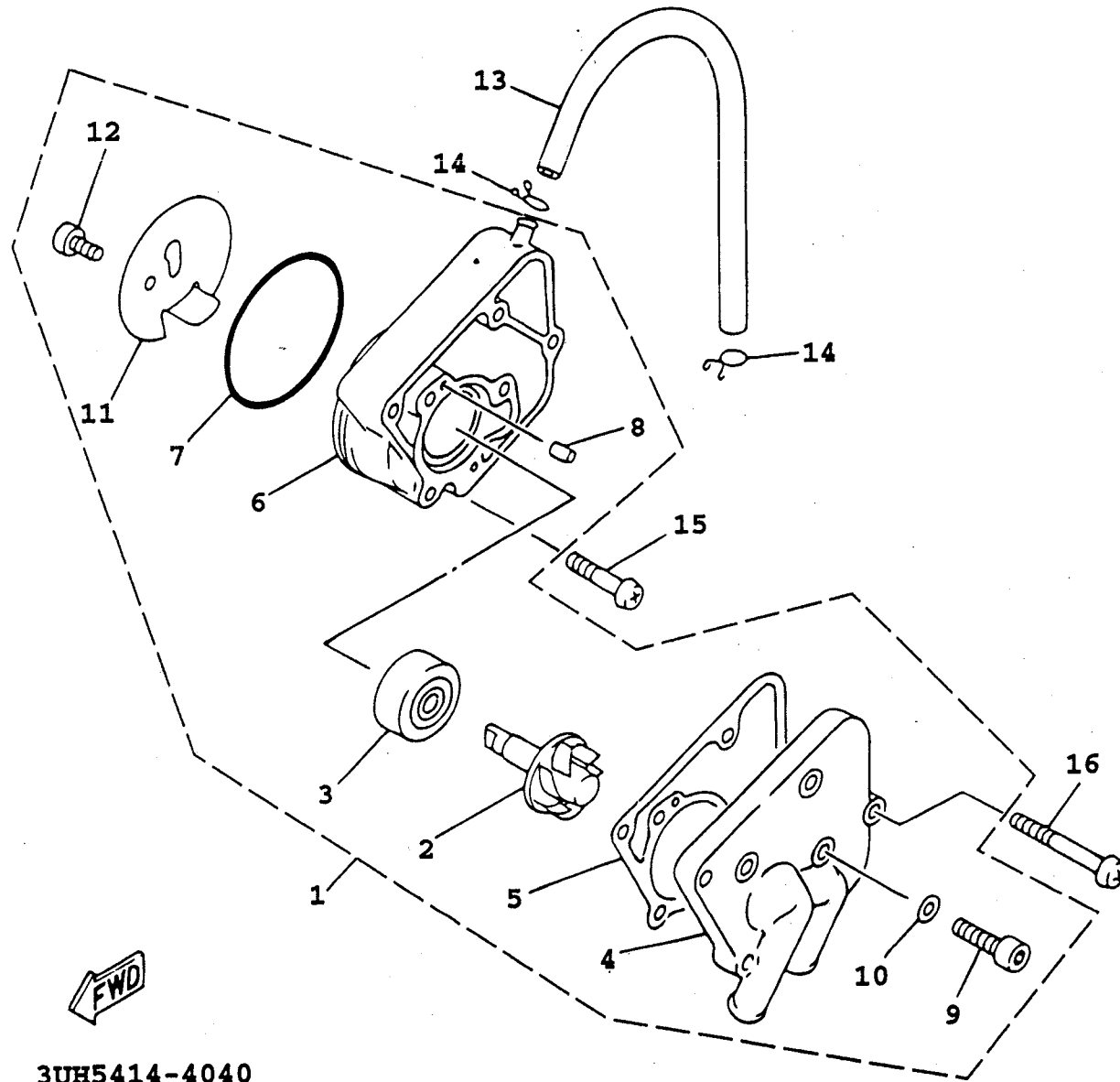

3UH5414-4040

FIG. 4 冷卻泵浦

項次	部品番號	英文名稱	中文名稱	用量	建議價格	備註	代碼	工時
1	5DS-E2420-00	WATER PUMP ASSY	冷卻泵浦總成	1	630			
2	3UH-E2450-00	.IMPELLER SHAFT ASSY	推進器	1	100			
3	93103-10168	.SEAL, OIL	油封	1	250			
4	5DS-E2422-00	.COVER, HOUSING	冷卻泵浦蓋	1	100			
5	4DH-E2428-00	.GASKET, HOUSING COVER 2	墊片	1	20			
6	5DS-E1185-00	.COVER, CYLINDER HEAD SIDE 1	汽缸頭側蓋	1	180			
7	93210-63881	.O-RING	護油圈	1	8			
8	93604-10011	.PIN	銷	2	23			
9	91317-06025	.BOLT, HEX. SOCKET	六角套頭螺栓	4	5			
10	90430-06166	.GASKET	墊片	1	5			
11	3UH-E1951-00	.PLATE	板	1	5			
12	98507-06012	.SCREW, PAN HEAD	盤頭螺絲	1	3			
13	5CA-E1166-00	PIPE, BREATHER 1	吸收器導管	1	15			
14	90467-10008	CLIP	止夾	2	5			
15	98507-06025	SCREW, PAN HEAD	盤頭螺絲	1	3			
16	98507-06050	SCREW, PAN HEAD	盤頭螺絲	2	3			

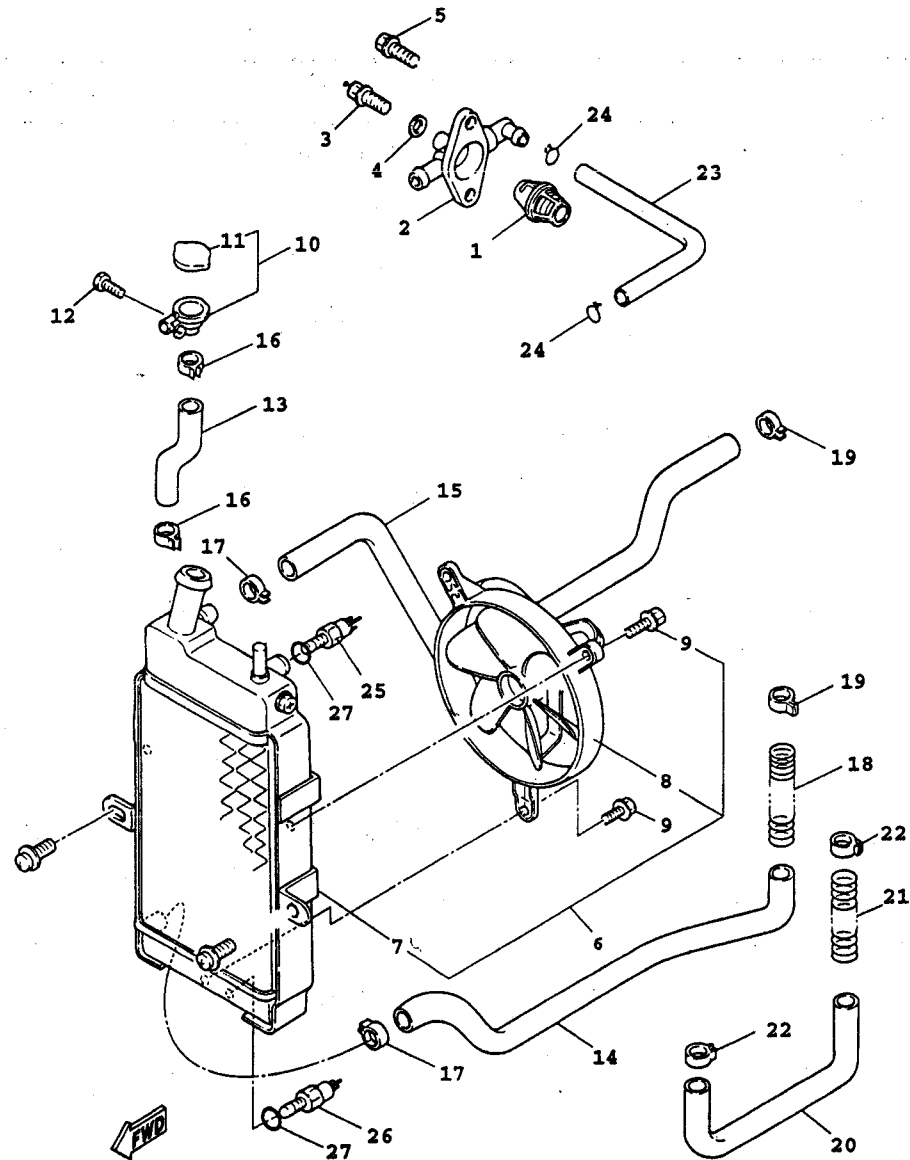

5CA1414-8051

FIG. 5 散熱裝置

項次	部品番號	英文名稱	中文名稱	用量	建議價格	備註	代碼	工時
1	4HC-12411-00	THERMOSTAT	恆溫器	1	620			
2	5CA-E2413-00	COVER, THERMOSTAT	恆溫器蓋	1	150			
3	91317-06010	BOLT, HEX. SOCKET	六角套頭螺栓	1	5			
4	90430-06166	GASKET	墊片	1	5			
5	95027-06020	BOLT, FLG	凸緣螺栓	2	5			
6	5CA-E240A-00	RADIATOR ASSY 2	散熱器總成	1	2,200			
7	5CA-E2460-00	.RADIATOR ASSY	水箱	1	1,160			
8	5CA-E2405-00	.BLOWER ASSY	鼓風機	1	1,040			
9	95027-06016	.BOLT, FLG	凸緣螺栓	3	3			
10	5CA-E2590-00	CONDUCTION ASSY	導流管	1	150			
11	5CA-E2462-00	.CAP, RADIATOR	水箱蓋	1	85			
12	97007-06012	BOLT, HEX	六角螺栓	1	3			
13	5CA-E2481-00	PIPE 1	管 1	1	50			
14	5CA-E2482-00	PIPE 2	管 2	1	90			
15	5CA-E2483-00	PIPE 3	管 3	1	110			
16	90467-21860	CLIP	止夾	2	10			
17	90467-20810	CLIP	止夾	2	7			
18	90501-10827	SPRING, COMPRESSION	壓力彈簧	1	28			
19	90450-25826	HOSE CLAMP ASSY	軟管夾	2	50			

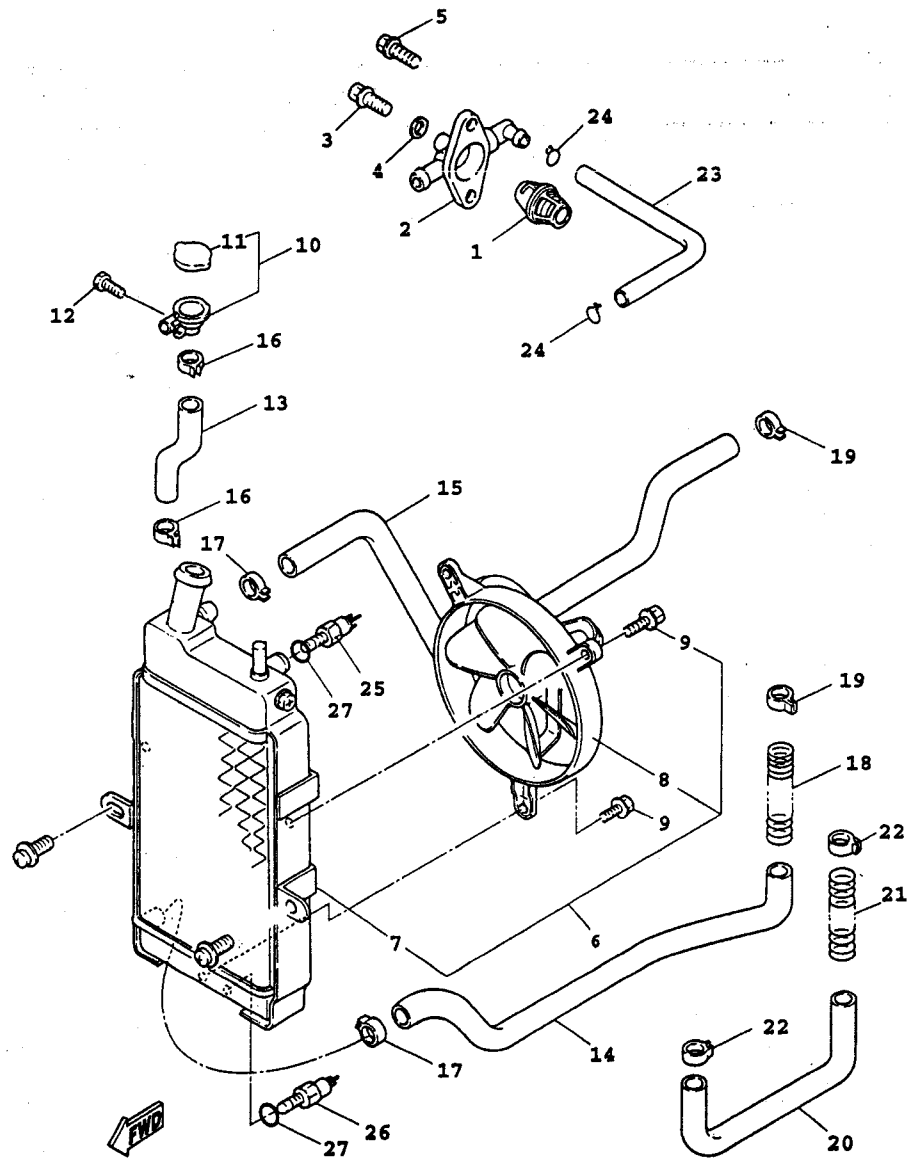

5CA1414-8051

FIG. 5 散熱裝置

項次	部品番號	英文名稱	中文名稱	用量	建議價格	備註	代碼	工時
20	5CA-E2477-00	PIPE 7	管 7	1	40			
21	90501-10826	SPRING, COMPRESSION	壓力彈簧	1	18			
22	90467-20810	CLIP	止夾	2	7			
23	5CA-E2576-00	HOSE 1	管	1	20			
24	90467-10857	CLIP	止夾	2	5			
25	5CA-82560-10	THERMO SWITCH ASSY	感溫器	1	800			
26	5CA-82560-01	THERMO SWITCH ASSY	感溫器	1	850			
27	93210-14801	O-RING	護油圈	2	5			

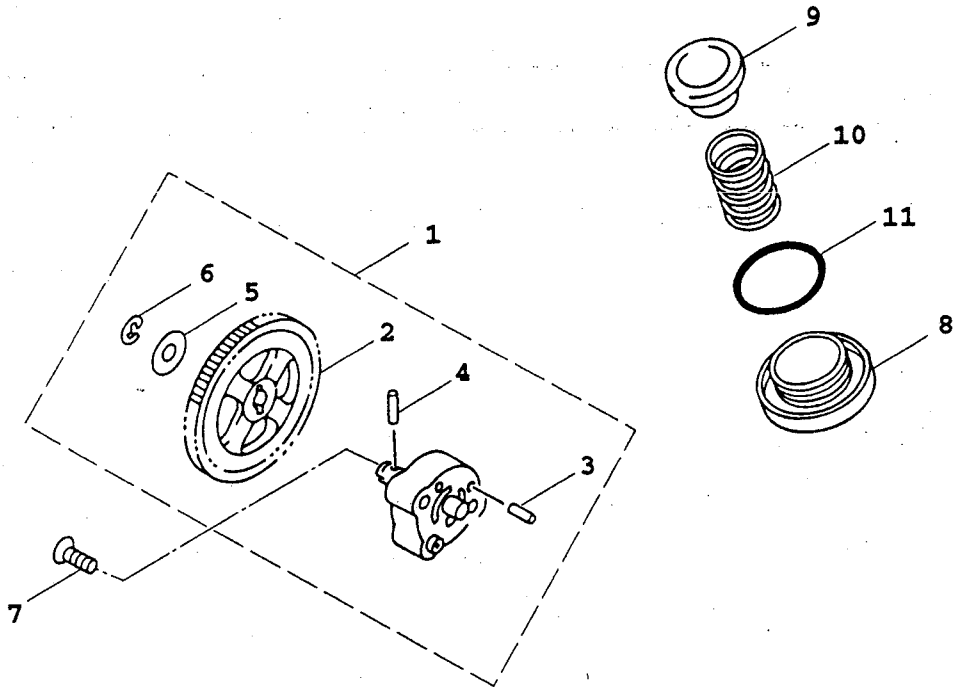

5CA1414-8060

FIG. 6 潤滑油泵

項次	部品番號	英文名稱	中文名稱	用量	建議價格	備註	代碼	工時
1	5CA-E3300-00	OIL PUMP ASSY	潤滑油泵總成	1	400			
2	3UH-E3325-00	.GEAR, PUMP DRIVEN	驅動齒輪	1	100			
3	93603-12833	.PIN DOWEL	定位銷	2	9			
4	93602-13832	.PIN, DOWEL	定位銷	1	5			
5	90201-077F5	.WASHER, PLATE	平墊圈	1	3			
6	99001-05600	.CIRCLIP	夾環	1	3			
7	98707-06020	SCREW, FLAT HEAD	平頭螺絲	2	3			
8	3UH-E5351-00	PLUG, DRAIN	排油塞	1	31			
9	3KW-E3411-00	STRAINER, OIL	過濾網	1	50			
10	90501-16829	SPRING, COMPRESSION	壓力彈簧	1	5			
11	93210-35879	O-RING	護油圈	1	5			

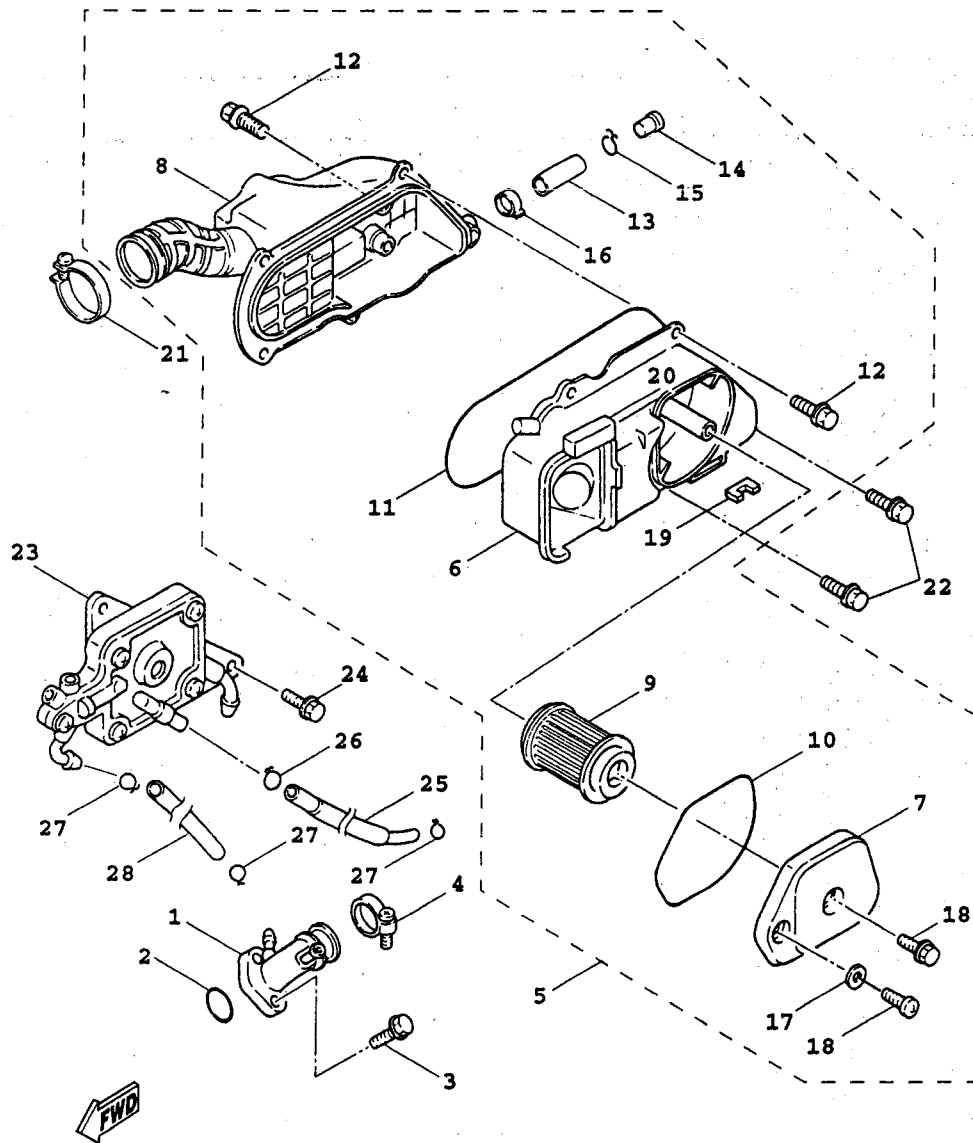

5CA1414-8070

FIG. 7 空氣吸入口

項次	部品番號	英文名稱	中文名稱	用量	建議價格	備註	代碼	工時
1	5CA-E3585-00	MANIFOLD	歧管	1	150			
2	93210-30611	O-RING	護油圈	1	10			
3	95027-06020	BOLT, FLG	凸緣螺栓	2	5			
4	5CA-E3575-00	BAND	束帶	1	20			
5	5CA-E4410-00	AIR CLEANER ASSY.	空氣濾清器總成	1	800			
6	5CA-W1441-00	.AIR CLEANER CASE COMP.	空氣濾清器箱組1	1	290			
7	5CA-E4412-00	.CAP, CLEANER CASE 1	空氣濾清器箱蓋	1	35			
8	5CA-W1442-00	.AIR CLEANER CASE COMP	空氣濾清器箱組2	1	260			
9	4TE-E4451-00	.ELEMENT, AIR CLEANER	空氣濾清網	1	100			
10	5CA-E4476-00	.SEAL	封圈	1	15			
11	5CA-E4452-00	.SEAL	封圈	1	20			
12	97607-06225	.SCREW, W/WASHER	六角螺栓附墊圈	7	3			
13	90446-13805	.HOSE	管	1	8			
14	90338-11820	.PLUG	塞	1	10			
15	90467-12052	.CLIP	止夾	1	5			
16	90467-13813	.CLIP	止夾	1	13			
17	90201-064H0	.WASHER, PLATE	平墊圈	2	3			
18	98507-06020	.SCREW, PAN HEAD	盤頭螺絲	2	3			
19	5CA-E4425-00	.DAMPER 1	防震墊	1	25			

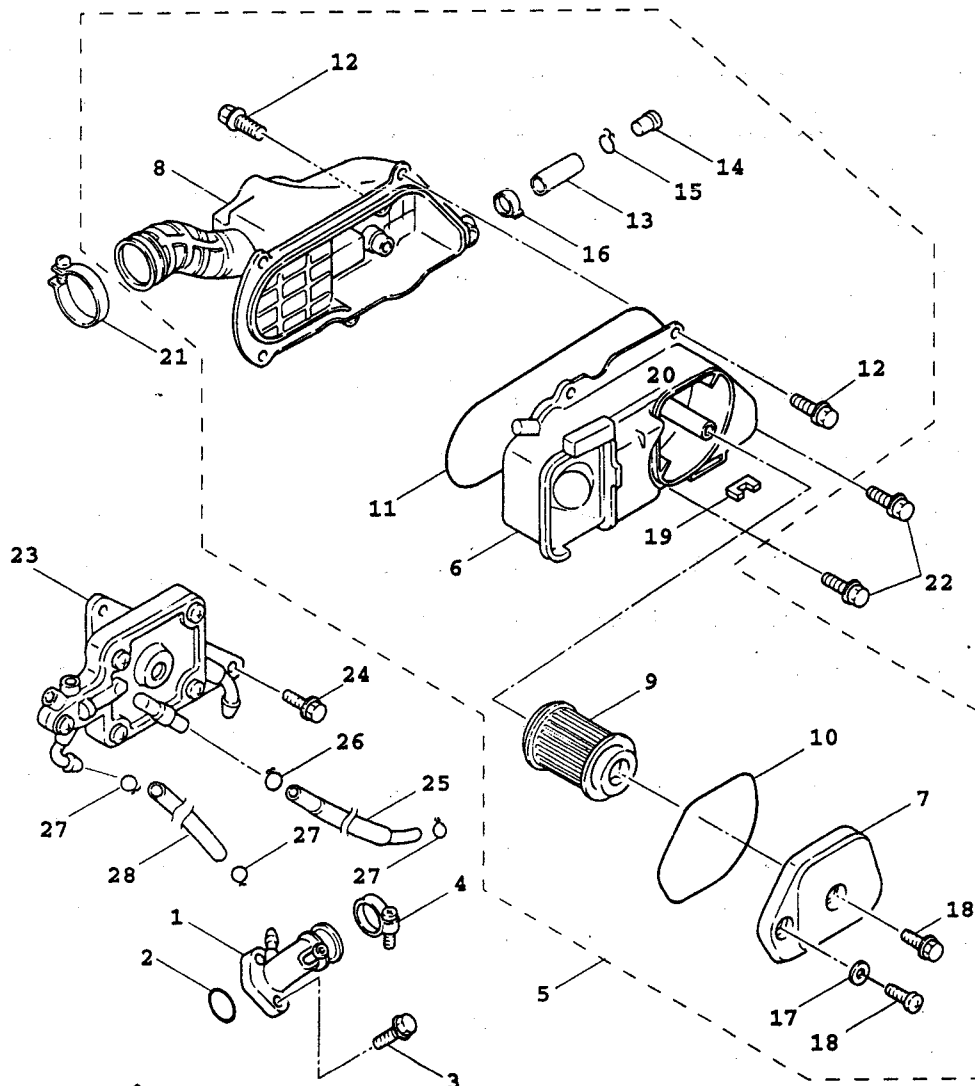

5CA1414-8070

FIG. 7 空氣吸入口

項次	部品番號	英文名稱	中文名稱	用量	建議價格	備註	代碼	工時
20	5CA-E4426-00	.DAMPER 2	防震墊	1	10			
21	90460-56287	CLAMP, HOSE	軟管夾	1	30			
22	97607-06225	SCREW, W/WASHER	六角螺栓附墊圈	2	3			
23	5CA-E3910-00	FUEL PUMP ASSY	汽油泵浦總成	1	650			
24	95027-06010	BOLT, FLG	凸緣螺栓	2	5			
25	5CA-E4294-00	HOSE	管	1	30			
26	90467-09006	CLIP	止夾	1	5			
27	90467-10008	CLIP	止夾	3	5			
28	5CA-E3929-00	PIPE, IMPULSE	管	1	10			

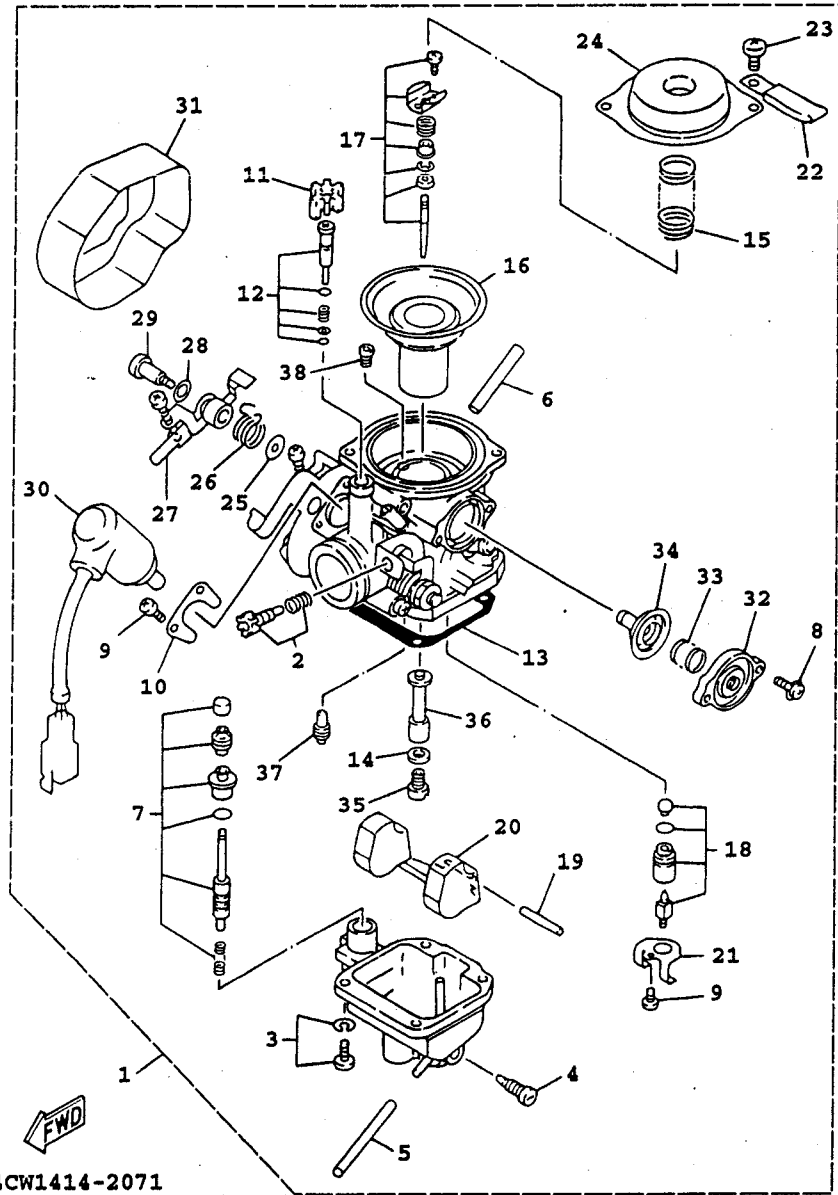

4CW1414-2071

FIG. 8 化油器

項次	部品番號	英文名稱	中文名稱	用量	建議價格	備註	代碼	工時
1	5CA-E4901-00	CARBURETOR ASSY 1	化油器總成	1	4,000			
2	4CW-14103-00	.THROTTLE SCREW SET	節流調整螺絲組	1	60			
3	97602-04114	.SCREW, PAN HEAD WITH WASHER	盤頭螺絲附墊圈	4	5			
4	12R-14191-00	.PLUG, DRAIN	排洩口塞	1	40			
5	3XV-14396-10	.PIPE	油管	1	45			
6	4CW-14197-00	.PIPE	油管	1	50			
7	4CW-14504-00	.ROD SET	節流螺絲組	1	228			
8	1UY-14565-00	.SCREW	螺絲	2	7			
9	98502-04006	.SCREW, PAN HEAD (+)	平頭螺絲	3	5			
10	4CW-14243-00	.PLATE	板	1	28			
11	1J7-14968-00	.CAP	蓋	1	8			
12	4CW-14105-00	.PILOT SCREW SET	螺絲組	1	78			
13	4CW-14959-00	.GASKET	墊片	1	30			
14	137-14153-00	.WASHER, MAIN JET	墊圈	1	15			
15	3UR-14933-00	.SPRING, DIAPHRAGM	彈簧	1	25			
16	4CW-14940-00	.DIAPHRAGM ASSY	節流閥	1	683			
17	5CA-1490J-00	.NEEDLE SET	油針組	1	150			
18	3KW-14107-20	.NEEDLE VALVE SET	針閥總成	1	150			
19	537-14186-00	.PIN, FLOAT	浮筒銷	1	18			

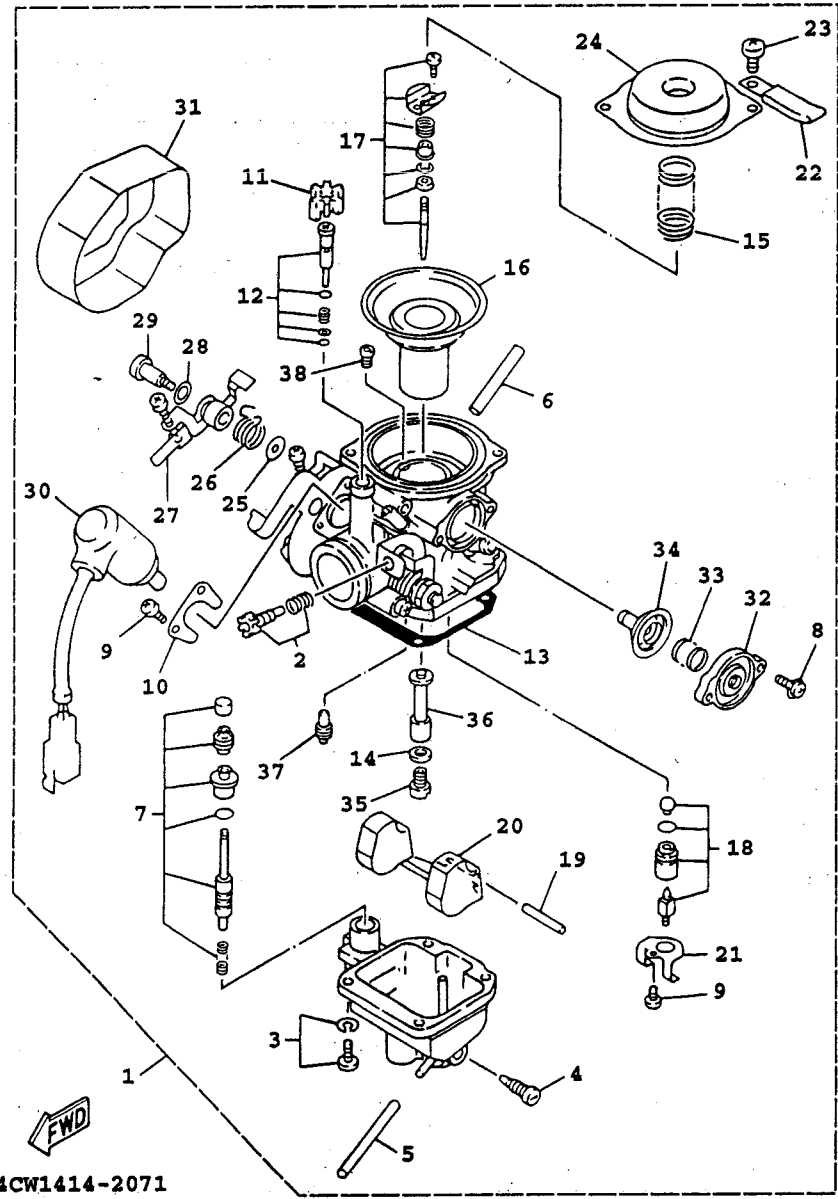

4CW1414-2071

FIG. 8 化油器

項次	部品番號	英文名稱	中文名稱	用量	建議價格	備註	代碼	工時
20	4G0-14985-00	.FLOAT	浮筒	1	75			
21	3UH-14945-00	.JET	板	1	10			
22	3UH-14146-00	.PLATE	板	1	7			
23	98702-04008	.SCREW, FLAT HEAD (+)	圓十字螺絲	2	5			
24	4CW-14958-00	.COVER, DIAPHRAGM	蓋	1	140			
25	4CW-14962-00	.WASHER	墊圈	1	13			
26	4CW-14589-00	.SPRING	彈簧	1	35			
27	4CW-14582-00	.LEVER	把手	1	143			
28	4CW-14117-00	.WASHER, PLUG SCREW	墊圈	1	7			
29	4CW-14115-00	.PLUG, SCREW	螺絲柱塞	1	18			
30	4CW-14171-00	.PLUNGER, STARTER	起動柱塞	1	1,150			
31	4CW-E4293-00	.COVER 1	蓋 1	1	25			
32	3LD-14958-00	.COVER, DIAPHRAGM	蓋	1	33			
33	26H-14275-00	.SPRING	彈簧	1	8			
34	620-14231-23	.JET, MAIN	主噴口	1				
35	22V-14940-00	.DIAPHRAGM ASSY	節流閥	1	15			
36	4TF-14141-34	.NOZZLE, MAIN	主噴嘴	1				
37	4G0-14142-50	.JET, PILOT	引導噴口	1	137			
38	3G2-14231-17	.JET, MAIN	主噴口	1				

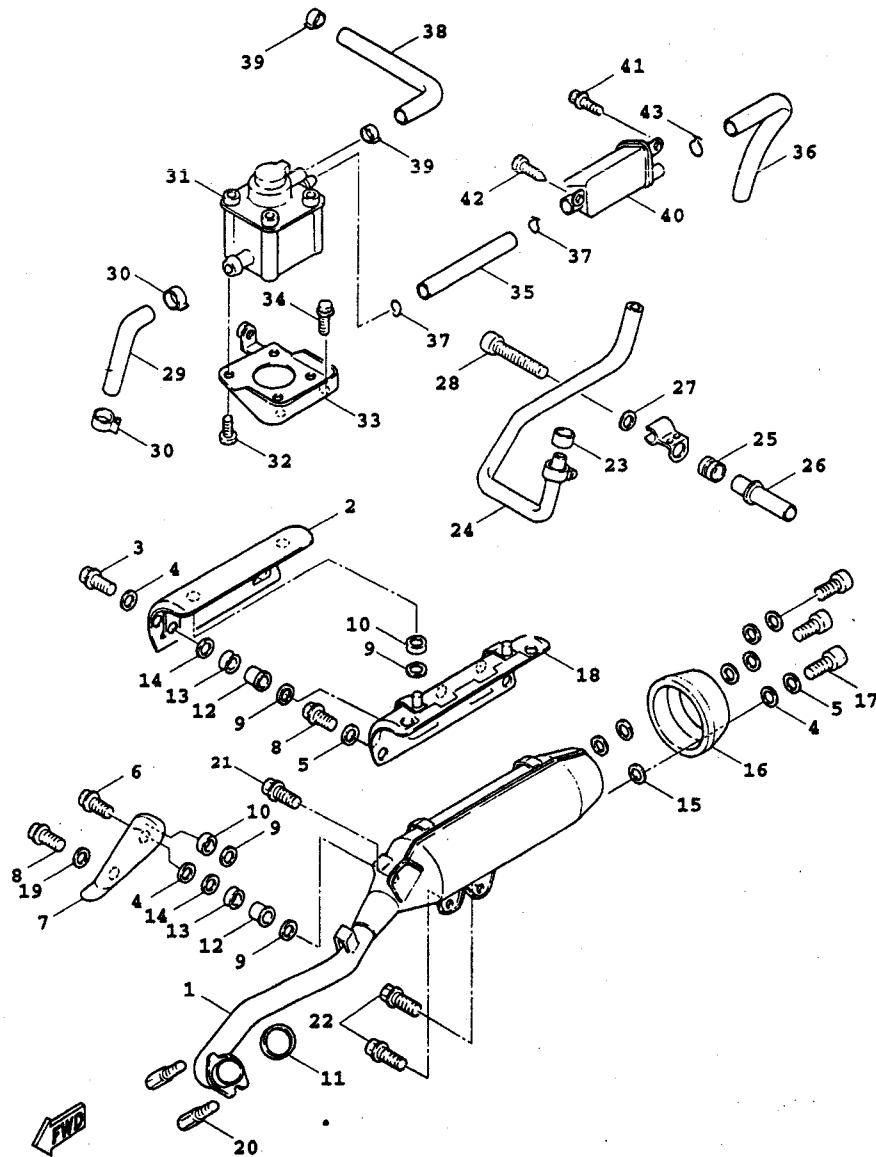

5CA1414-8091

FIG. 9 排氣裝置

項次	部品番號	英文名稱	中文名稱	用量	建議價格	備註	代碼	工時
1	5CA-E4610-00-98	EXHAUST PIPE ASSY 1	排氣管總成	1	4,000	平光黑色		
2	5CA-E4708-01	PROTECTOR ASSY	保護罩總成	1	500			
3	98980-06020	SCREW, BINDING HEAD (+)	有帽螺絲	2	5			
4	5CA-E4766-10	WASHER, PROTECTOR	墊圈	6	5			
5	92907-06200	WASHER, PLATE	平墊圈	9	3			
6	98907-06020	SCREW, BIND HEAD	有帽螺絲	1	3			
7	5CA-E4728-00	PROTECTOR, MUFFLER 2	消音筒護罩	1	180			
8	91317-06010	BOLT, HEX. SOCKET	六角套頭螺栓	7	5			
9	5CA-E4766-00	WASHER, PROTECTOR	墊圈	6	5			
10	90480-12887	GROMMET	索環	3	10			
11	3UH-E4613-00	GASKET, EXHAUST PIPE	排氣管墊片	1	11			
12	90387-068X3	COLLAR	軸環	3	10			
13	90480-14889	GROMMET	索環	3	10			
14	90201-067L0	WASHER, PLATE	平墊圈	3	5			
15	4CW-E4766-00	WASHER, PROTECTOR	墊圈	3	5			
16	5CA-E4799-00	CAP	蓋	1	110			
17	91380-06012	BOLT	螺栓	3	5			
18	5CA-E4627-00	EXHAUST COVER ASSY	排氣管蓋總成	1	210			
19	92907-06600	WASHER, PLATE	平墊圈	1	3			

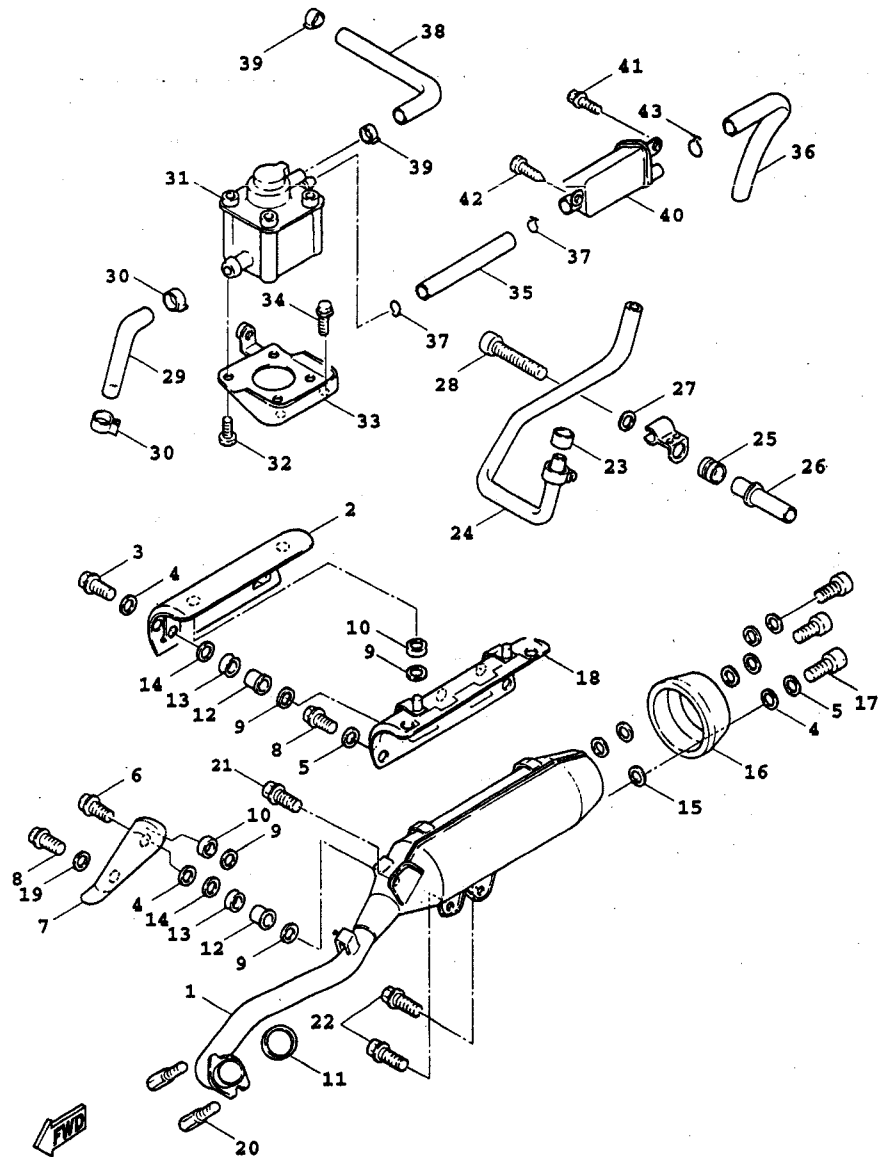

5CA1414-8091

FIG. 9 排氣裝置

項次	部品番號	英文名稱	中文名稱	用量	建議價格	備註	代碼	工時
20	90179-06850	NUT	螺帽	2	8			
21	95817-08020	BOLT, FLG	凸緣螺栓	1	5			
22	95817-08030	BOLT, FLG	凸緣螺栓	2	5			
23	42H-14714-10	GASKET, MUFFLER	消音筒接合墊片	1	115			
24	5CA-E4872-00	PIPE 2	管 2	1	350			
25	90480-15520	GROMMET	索環	1	7			
26	5CA-E4876-00	PIPE 6	管 6	1	40			
27	90201-06557	WASHER, PLATE	平墊圈	1	3			
28	91317-06070	BOLT, HEX. SOCKET	六角套頭螺栓	1	5			
29	5CA-E4883-00	HOSE, BEND 3	管	1	20			
30	90468-08812	CLIP	止夾	2	12			
31	5CA-E4803-00	AIS ASSY	二次空氣導入系統	1	1,500			
32	98507-05012	SCREW, PAN HEAD	盤頭螺絲	4	3			
33	5CA-E4849-00	BRACKET	支架	1	35			
34	95827-06012	BOLT, FLG	凸緣螺栓	2	3			
35	5CA-E4884-00	HOSE, BEND 4	管	1	40			
36	5CA-E4885-00	HOSE, BEND 5	管	1	25			
37	90467-16829	CLIP	止夾	2	7			
38	5CA-E3542-00	HOSE, VACUUM SENSING 1	管	1	15			

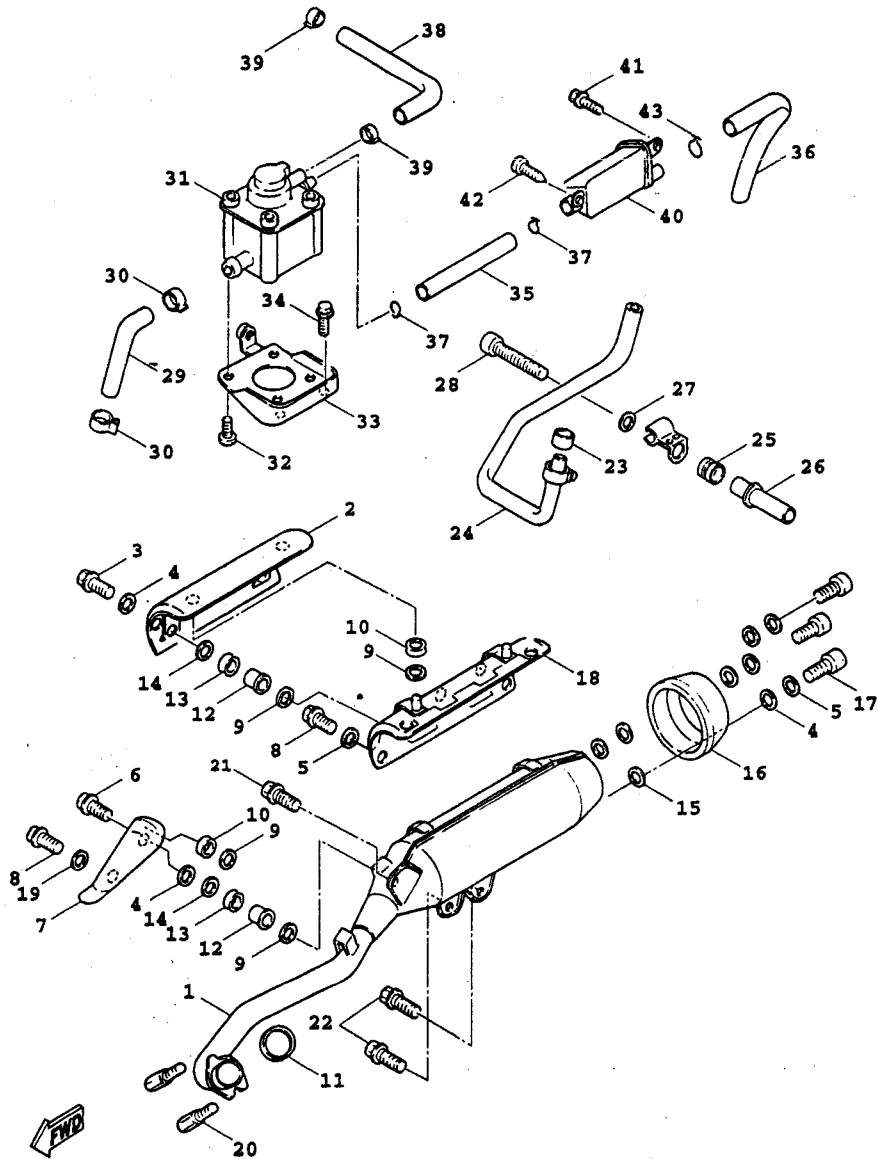

5CA1414-8091

FIG. 9 排氣裝置

項次	部品番號	英文名稱	中文名稱	用量	建議價格	備註	代碼	工時
39	90467-08092	CLIP	止夾	2	12			
40	4CW-E4806-00	AIR FILTER CASE ASSY.	空氣過濾器總成	1	96			
41	95807-06016	BOLT, FLG	凸緣螺栓	1	3			
42	97707-50016	SCREW, TAPPING	攻螺絲	1	3			
43	90467-16829	CLIP	止夾	1	7			

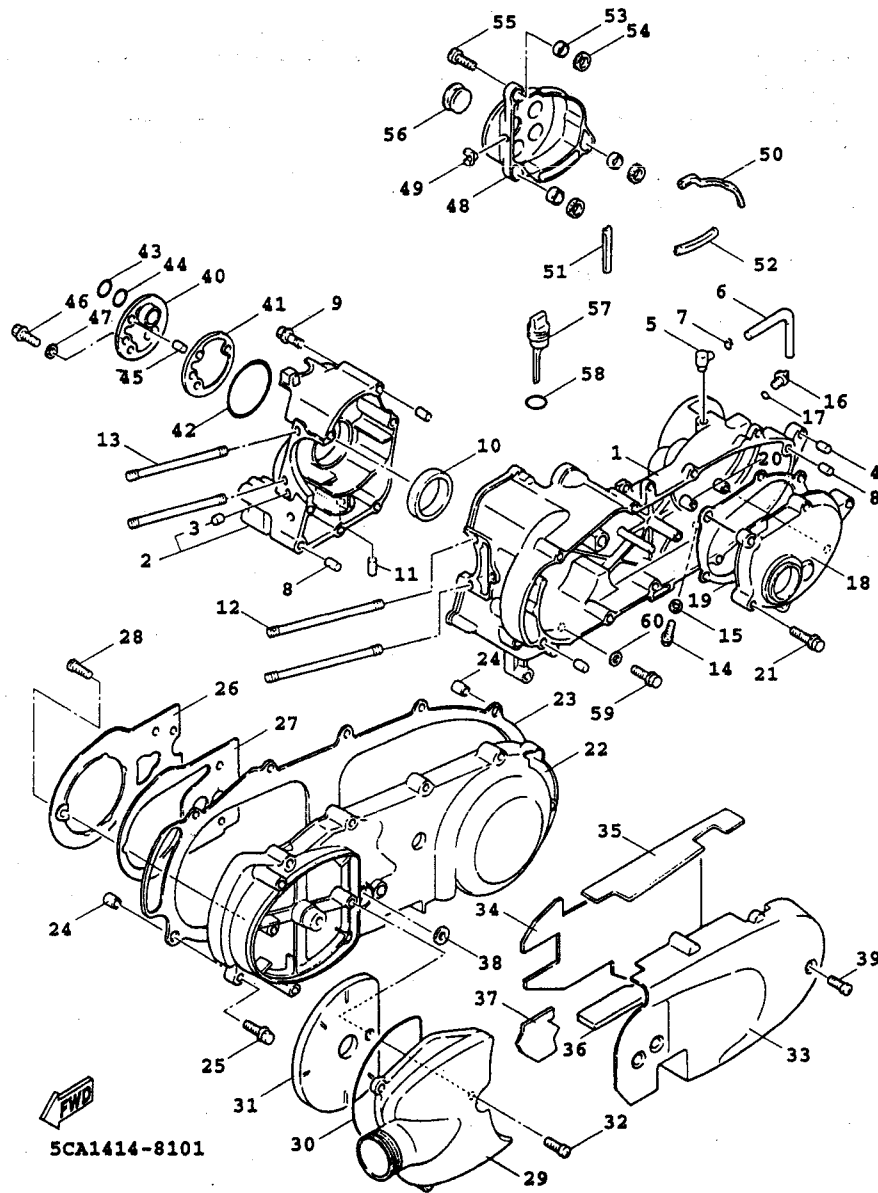

5CA1414-8101

FIG. 10 曲軸箱

項次	部品番號	英文名稱	中文名稱	用量	建議價格	備註	代碼	工時
1	5CA-E5111-00	CRANKCASE 1	左曲軸箱	1	1,500			
2	5CA-W1512-00	CRANKCASE 2	右曲軸箱總成	1	1,200			
3	5CA-E5138-00	.NOZZLE 1	噴嘴	1	20			
4	4X6-F2216-00	BUSH, REAR SHOCK ABSORBER	後緩衝器襯套	1	11			
5	5CA-E5371-00	BREATHER	溢氣管	1	35			
6	5CA-E5373-00	PIPE, BREATHER	通氣管	1	15			
7	90467-12052	CLIP	止夾	1	5			
8	99530-10114	PIN, DOWEL	定位銷	2	10			
9	95027-06080	BOLT, FLG	凸緣螺栓	8	5			
10	93102-22843	SEAL, OIL	油封	1	10			
11	3UH-E3416-00	PIPE, OIL 1	油管	1	7			
12	90116-08836	BOLT, STUD	雙頭螺栓	2	20			
13	90116-08839	BOLT, STUD	雙頭螺栓	2	20			
14	95817-08016	BOLT, FLG	凸緣螺栓	1	5			
15	90430-08816	GASKET	墊片	1	7			
16	4Y4-E5363-00	PLUG, OIL	油塞	1	5			
17	93210-14805	O-RING	護油圈	1	3			
18	5CA-E5421-00	COVER, CRANKCASE 2	曲軸箱蓋 2	1	400			
19	5CA-E5461-00	GASKET, CRANKCASE COVER 2	曲軸箱蓋墊片 2	1	15			

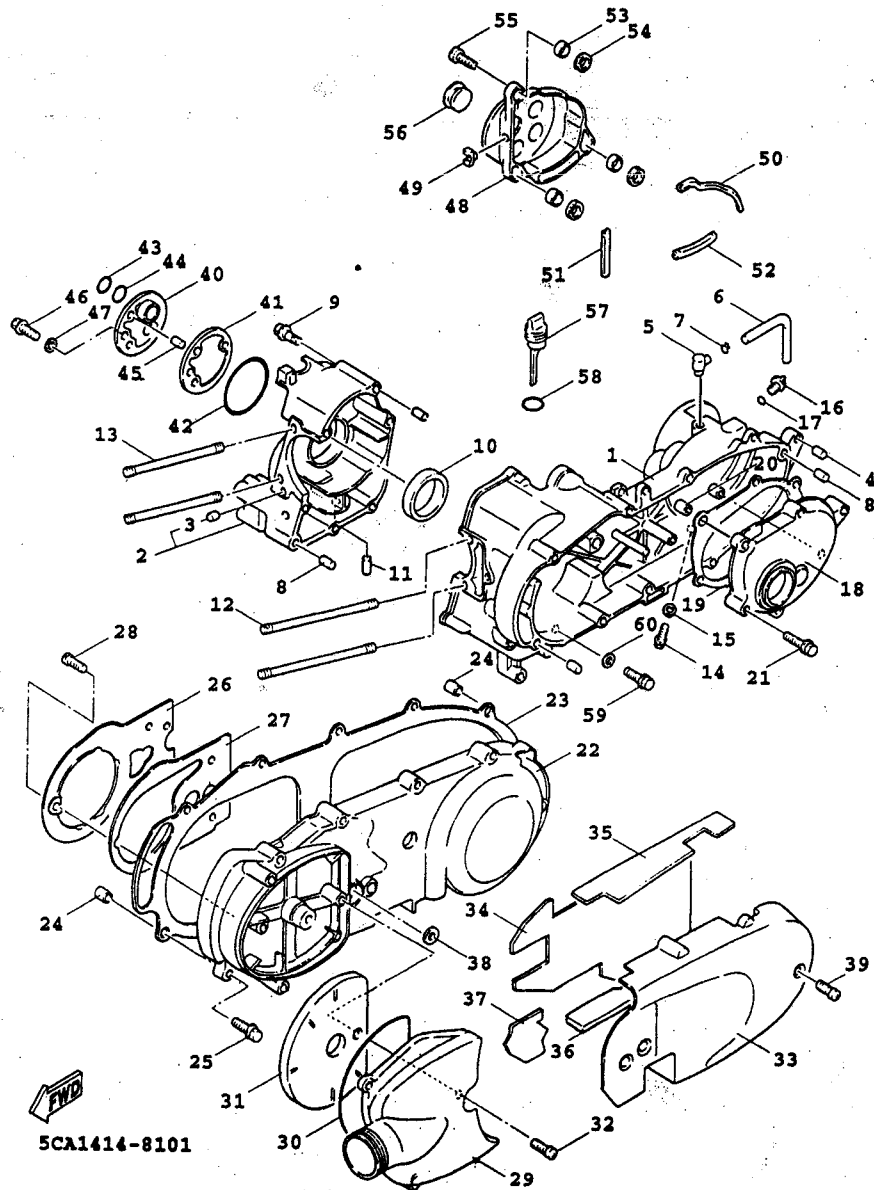

5CA1414-8101

FIG. 10 曲軸箱

項次	部品番號	英文名稱	中文名稱	用量	建議價格	備註	代碼	工時
20	99530-10114	PIN, DOWEL	定位銷	2	10			
21	95027-06030	BOLT, FLG	凸緣螺栓	6	5			
22	5CA-E5411-00	COVER, CRANKCASE 1	曲軸箱蓋 1	1	700			
23	5CA-E5451-00	GASKET, CRANKCASE COVER 1	曲軸箱蓋墊片 1	1	80			
24	99530-10114	PIN, DOWEL	定位銷	2	10			
25	95027-06035	BOLT, FLG	凸緣螺栓	11	5			
26	5CA-E5191-00	PLATE	板	1	40			
27	5CA-E5455-00	GASKET 1	墊片	1	25			
28	98907-06010	SCREW, BIND HEAD	有帽螺絲	3	3			
29	5CA-E5471-00	DUCT, AIR	導管	1	70			
30	5CA-E5472-00	SEAL, AIR DUCT	橡皮墊圈	1	10			
31	5CA-E5407-00	ELEMENT 1	過濾器	1	35			
32	98907-06020	SCREW, BIND HEAD	有帽螺絲	3	3			
33	5CA-E5431-00	COVER, CRANKCASE 3	曲軸箱蓋 3	1	50			
34	5CA-E5316-00	DAMPER, ENGINE MOUNT 1	防震墊	1	40			
35	5CA-E5326-00	DAMPER, ENGINE MOUNT. 2	防震墊	1	30			
36	5CA-E5335-00	DAMPER 3	防震墊	1	20			
37	5CA-E5337-00	DAMPER 4	防震墊	1	10			
38	4CW-E5379-00	SEAL, CRANKCASE	封圈	1	8			

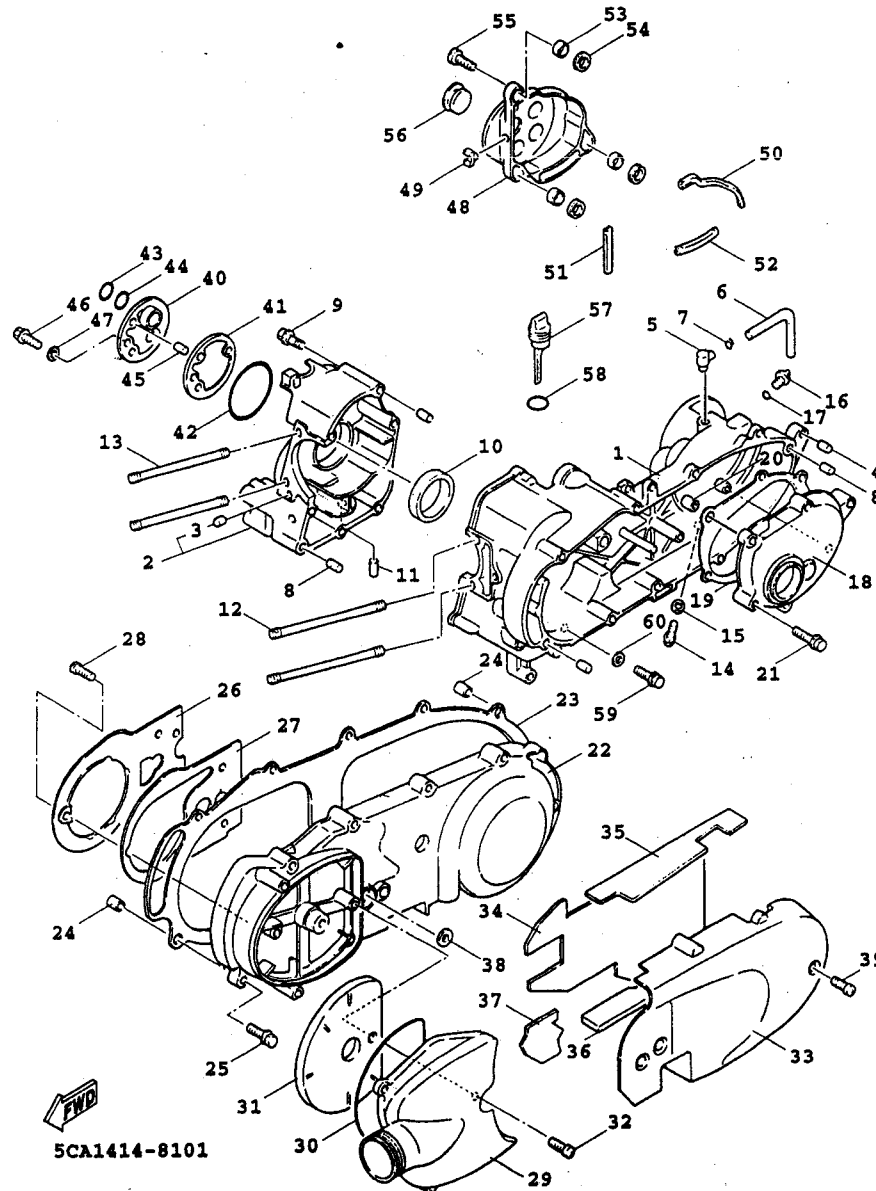

5CA1414-8101

FIG. 10 曲軸箱

項次	部品番號	英文名稱	中文名稱	用量	建議價格	備註	代碼	工時
39	4DM-E5481-00	BOLT 1	螺栓	2	12			
40	5CA-E5417-00	COVER, CAP	蓋	1	140			
41	5CA-E5453-00	GASKET, CARBURETOR COVER	墊片	1	10			
42	93211-077A5	O-RING	護油圈	1	45			
43	93101-19172	SEAL, OIL	油封	1	50			
44	93102-19477	SEAL, OIL	油封	1	150			
45	99530-08012	PIN, DOWEL	定位銷	1	7			
46	95027-06020	BOLT, FLG	凸緣螺栓	3	5			
47	90430-06014	GASKET	墊片	3	5			
48	5CA-E5426-00	COVER, OIL PUMP 2	蓋	1	50			
49	90464-08020	CLAMP	夾	1	5			
50	5CA-E542A-00	DAMPER, COVER 1	防震墊	1	10			
51	5CA-E542B-00	DAMPER, COVER 2	防震墊	1	5			
52	5CA-E542C-00	DAMPER, COVER 3	防震墊	1	5			
53	90387-068F9	COLLAR	軸環	3	5			
54	90480-12497	GROMMET	索環	3	5			
55	98507-06020	SCREW, PAN HEAD	盤頭螺絲	3	3			
56	90480-30167	GROMMET	索環	1	5			
57	5CA-E5363-00	PLUG, OIL	油塞	1	15			

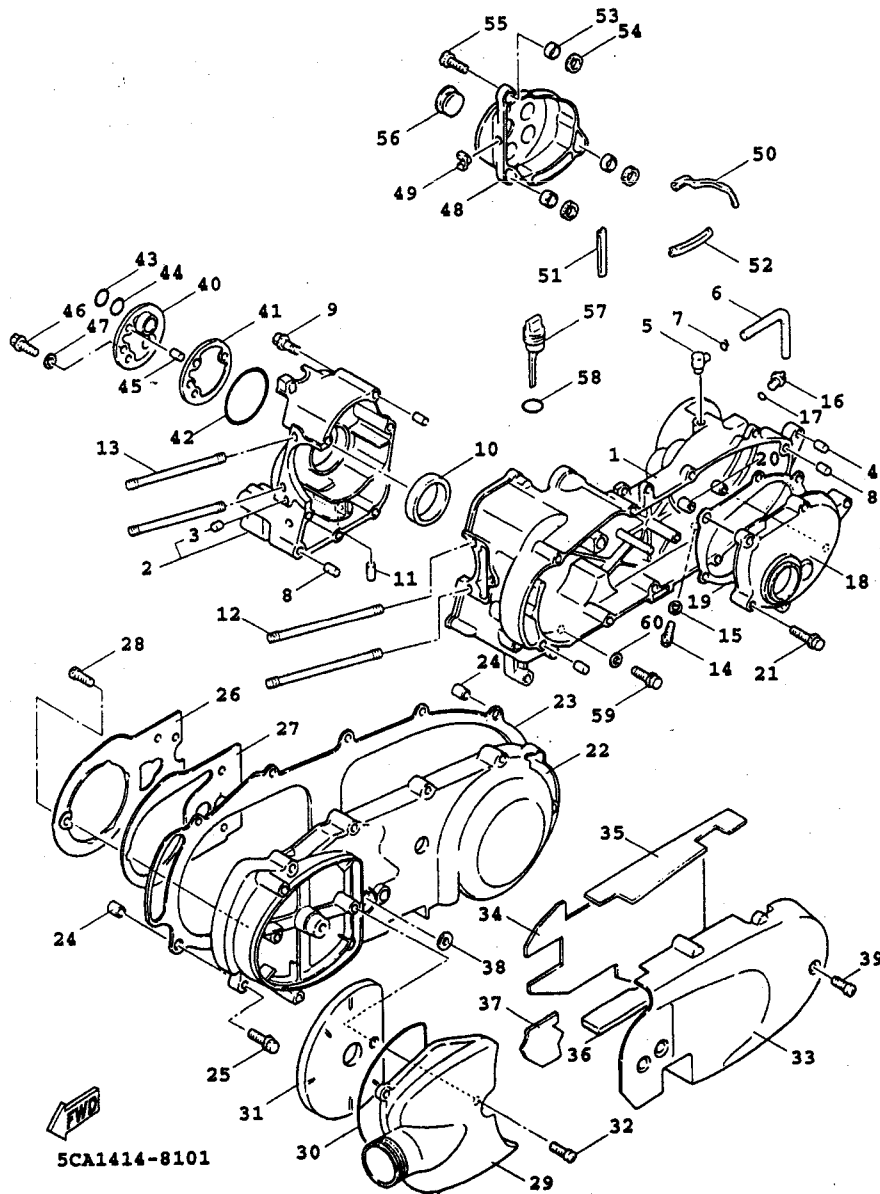

5CA1414-8101

FIG. 10 曲軸箱

項次	部品番號	英文名稱	中文名稱	用量	建議價格	備註	代碼	工時
58	93210-268H1	O-RING	護油圈	1	5			
59	95817-08016	BOLT, FLG	凸緣螺栓	1	5			
60	90430-08816	GASKET	墊片	1	7			

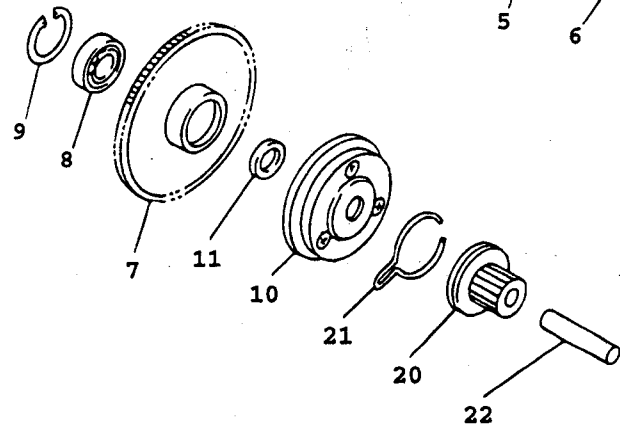
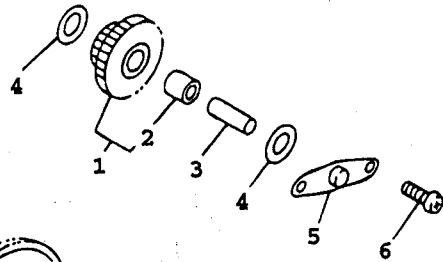
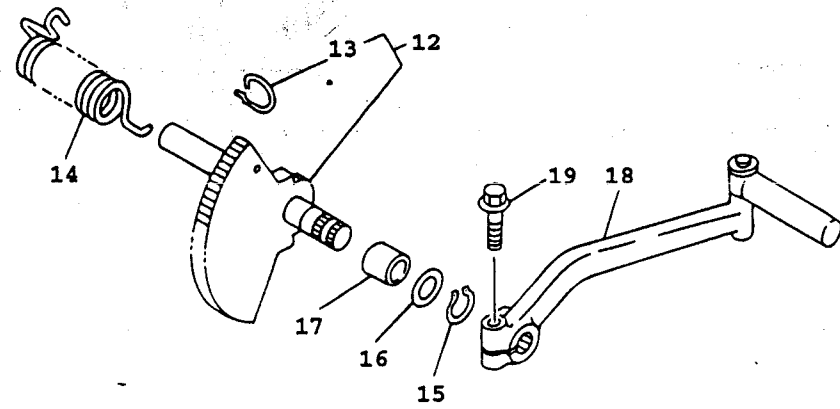

3UH1414-1120

FIG. 11 起動機構

項次	部品番號	英文名稱	中文名稱	用量	建議價格	備註	代碼	工時
1	5CA-E5650-00	IDLE GEAR ASSY	惰齒輪總成	1	500			
2	93315-110Y6	.BRG.	軸承	1	80			
3	5CA-E5521-00	SHAFT 1	軸1	1	15			
4	90201-108A3	WASHER, PLATE	平墊圈	2	5			
5	3UH-E5532-00	PLATE, IDLE GEAR	惰齒輪板	1	17			
6	98507-06012	SCREW, PAN HEAD	盤頭螺絲	2	3			
7	5CA-E5524-00	WHEEL, STARTER	起動輪	1	340			
8	93306-003Y4	BRG.	軸承	1	93			
9	93450-35015	CIRCLIP	夾環	1	7			
10	4CW-E5570-00	STARTER CLUTCH ASSY	起動離合器總成	1	600			
11	90387-168S2	COLLAR	軸環	1	10			
12	4CW-E5601-00	KICK SHAFT ASSY	腳踩軸總成	1	264			
13	4CW-E5687-00	.CLIP	止夾	1	7			
14	90508-40850	SPRING, TORSION	扭轉彈簧	1	60			
15	99009-17400	CIRCLIP	夾環	1	5			
16	90201-175F6	WASHER, PLATE	平墊圈	1	3			
17	90380-17806	BUSH, SOLID	實心襯套	1	7			
18	4CW-E5620-00	KICK CRANK ASSY	腳踩柄總成	1	134			
19	91317-08030	BOLT, HEX. SOCKET	六角套頭螺栓	1	7			

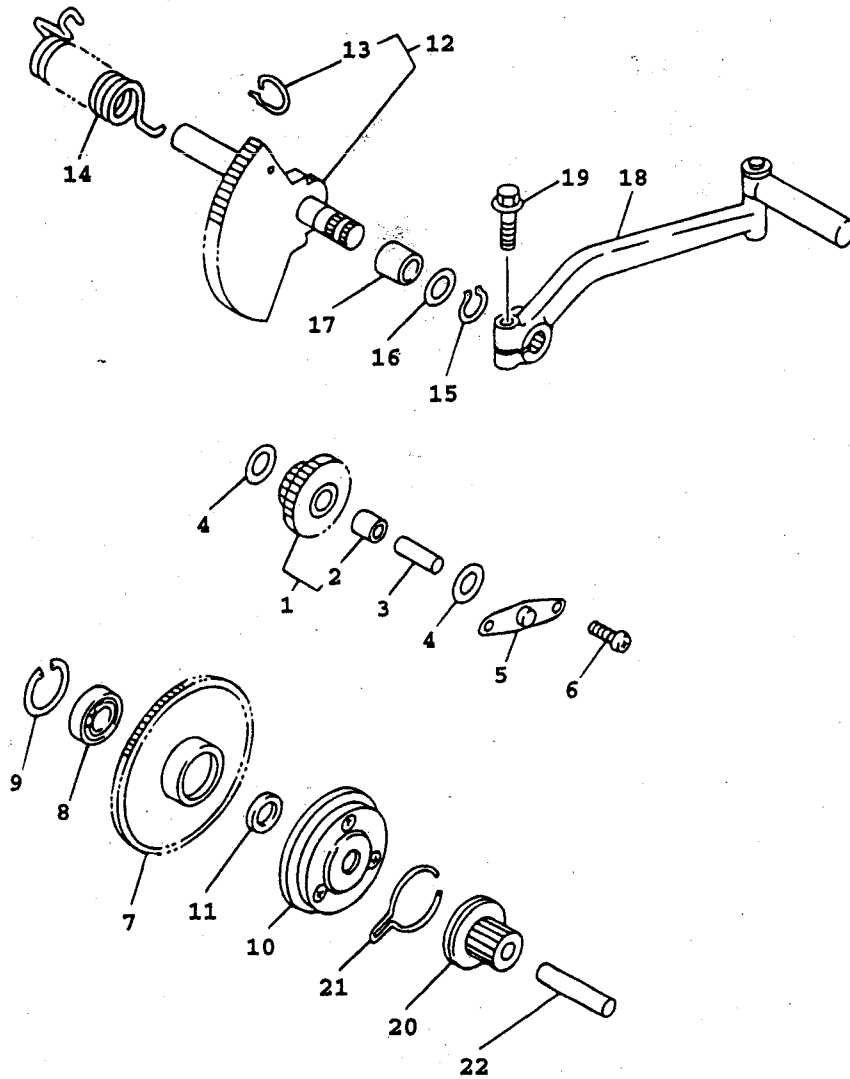

3UH1414-1120

FIG. 11 起動機構

項次	部品番號	英文名稱	中文名稱	用量	建議價格	備註	代碼	工時
20	4CW-E5630-00	KICK PINION ASSY	腳踩小齒輪	1	250			
21	4CW-E5673-00	CLIP	止夾	1	14			
22	4CW-E5659-00	SHAFT	軸	1	35			

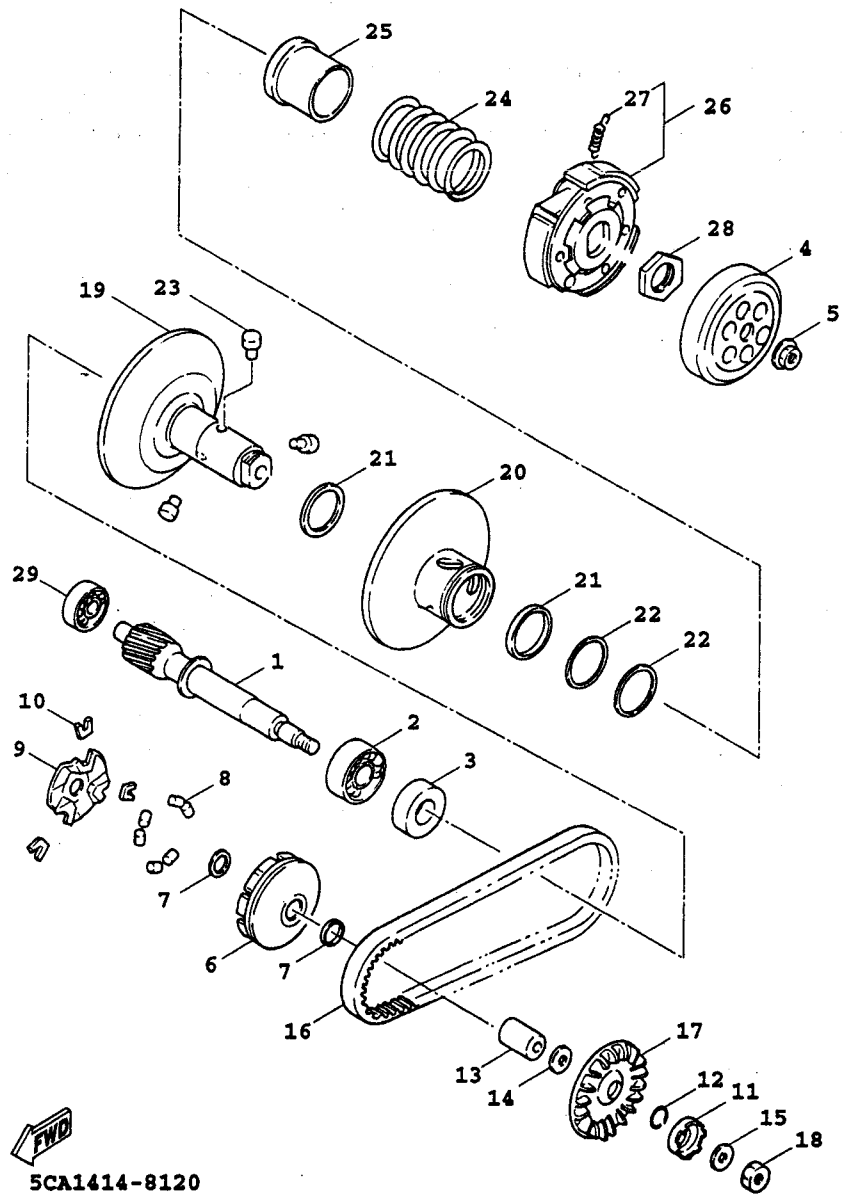

5CA1414-8120

FIG. 12 離合器

項次	部品番號	英文名稱	中文名稱	用量	建議價格	備註	代碼	工時
1	5CA-E6111-00	GEAR, PRIMARY DRIVE	主驅動齒輪	1	450			
2	93306-20427	BRG.	軸承	1	520			
3	93102-22800	SEAL, OIL	油封	1	50			
4	4CW-E6611-00	CLUTCH HOUSING COMP.	離合器殼整體	1	300			
5	90179-14427	NUT	螺帽	1	13			
6	5CA-E7620-00	PRIMARY SLIDING SHEAVE COMP.	主滑動槽輪整體	1	500			
7	93101-21170	SEAL, OIL	油封	2	145			
8	4TE-E7632-00	WEIGHT	滾珠	6	30			
9	4CW-E7623-00	CAM	凸輪	1	50			
10	4CW-17653-10	SLIDER	滑件	3	35			
11	3UH-E5657-00	CLUTCH, ONEWAY	單向離合器	1	135			
12	90208-12050	WASHER, CONICAL SPRING	錐形彈簧墊圈	1	5			
13	90387-168D2	COLLAR	軸環	1	100			
14	90201-163J6	WASHER, PLATE	平墊圈	1	16			
15	90201-164J0	WASHER, PLATE	平墊圈	1	5			
16	5DS-17641-00	V-BELT	皮帶	1	1,470			
17	4HP-E7611-00	SHEAVE, PRIMARY FIXED	主固定槽輪	1	300			
18	90170-12338	NUT	六角螺帽	1	7			
19	3UH-E7660-00	SECONDARY FIXED SHEAVE COMP.	副固定槽輪	1	1,000			

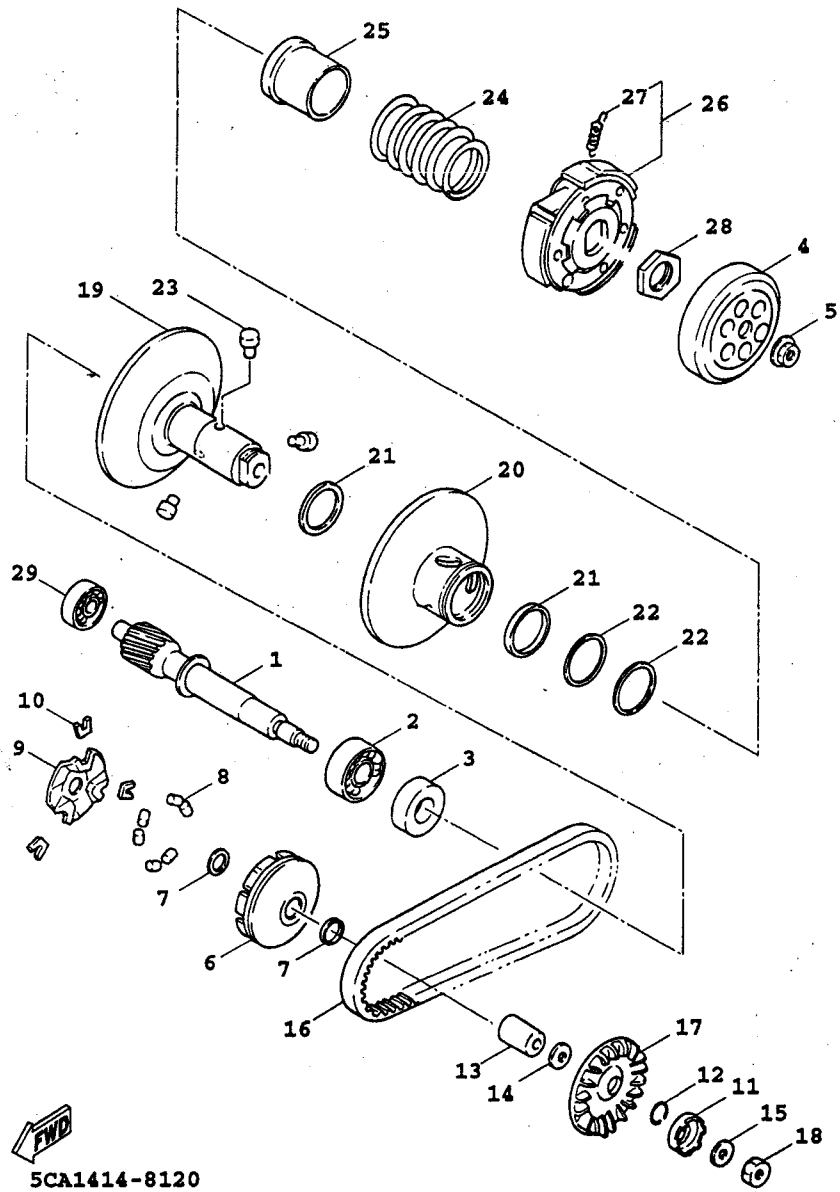

5CA1414-8120

FIG. 12 離合器

項次	部品番號	英文名稱	中文名稱	用量	建議價格	備註	代碼	工時
20	5CA-E7670-00	SECONDARY SLIDING SHEAVE	副滑動槽輪	1	500			
21	93104-41119	SEAL, OIL	油封	2	100			
22	93210-438H2	O-RING	護油圈	2	5			
23	4CW-E7664-00	PIN, GUIDE	導銷	3	10			
24	90501-452J8	SPRING, COMPRESSION	壓力彈簧	1	515			
25	3UH-E7684-00	SEAT, SECONDARY SPRING	副彈簧座	1	50			
26	4TE-E6620-00	CLUTCH CARRIER ASSY	離合器牽轉具總成	1	1,200			
27	4CW-E6626-00	.SPRING, CLUTCH WEIGHT	離合器回位彈簧	3	10			
28	90170-36279	NUT	六角螺帽	1	96			
29	93306-203Y0	BRG.	軸承	1	53			
30	4TE-W1763-10	WEIGHT	滾珠組	1	180			

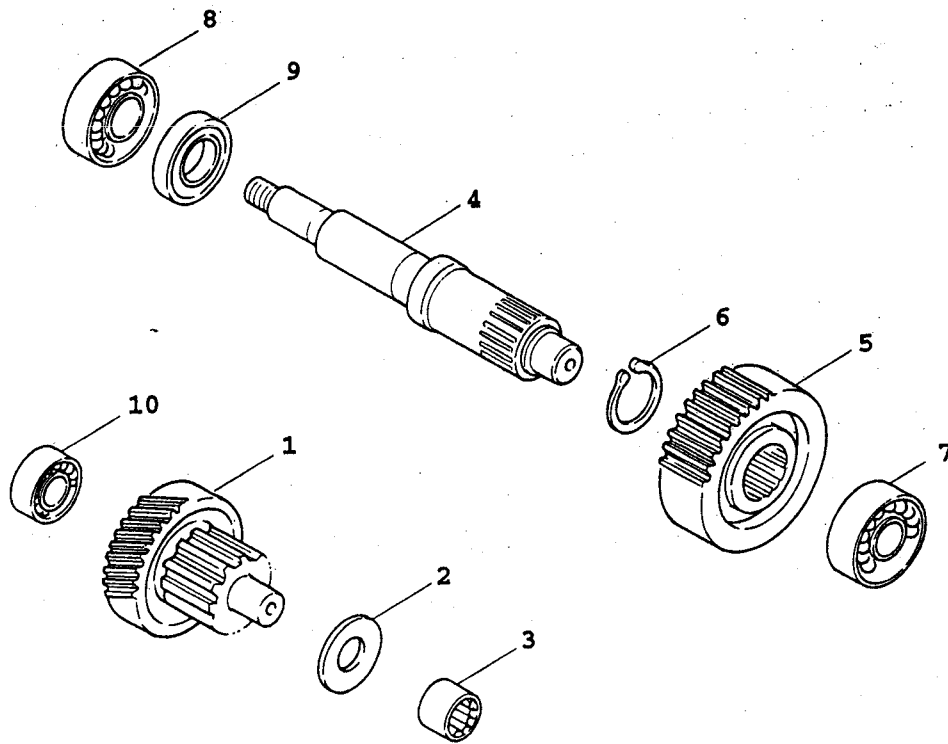

5CA1414-8130

FIG. 13 傳動機構

項次	部品番號	英文名稱	中文名稱	用量	建議價格	備註	代碼	工時
1	5CA-E7410-00	MAIN AXLE COMP.	主軸總成	1	500			
2	90201-158B8	WASHER, PLATE	平墊圈	0	7			
3	93311-315Y2	BRG.	軸承	1	100			
4	5CA-E7421-00	AXLE, DRIVE	驅動軸	1	400			
5	5CA-E7211-00	GEAR, 1ST WHEEL	1 檔從動齒輪	1	400			
6	99009-25400	CIRCLIP	夾環	1	5			
7	93306-303Y8	BRG.	軸承	1	70			
8	93306-272Y0	BRG.	軸承	1	120			
9	93102-32894	SEAL, OIL	油封	1	15			
10	93306-30101	BEARING (6301)	軸承	1	55			

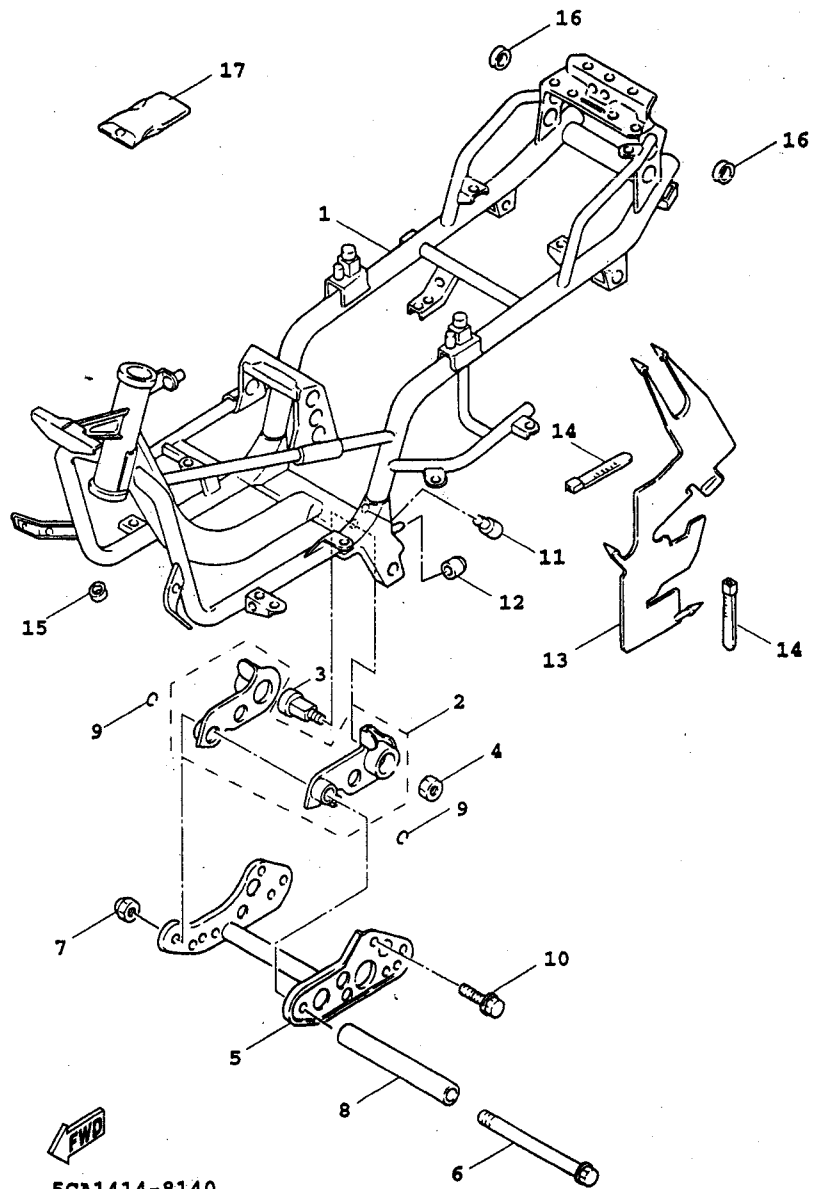

5CA1414-8140

FIG. 14 車架

項次	部品番號	英文名稱	中文名稱	用量	建議價格	備註	代碼	工時
1	5CA-F1110-00-33	FRAME COMP.	車架整體	1	6,000	山葉黑色 5CA4, 5CA7		
	5CA-F1110-10-33	FRAME COMP.	車架整體	1	6,000	山葉黑色 5CA8		
2	5CA-F1420-11	ENGINE BRACKET COMP	引擎支架整體	1	500			
3	4CW-F1481-00	BOLT, ENGINE MOUNTING 1	引擎裝置螺栓	2	10			
4	95607-10200	NUT, SELF-LOCKING	U型螺帽	2	5			
5	5CA-F1410-00	ENGINE BRACKET COMP.	引擎支架整體	1	240			
6	90105-10836	BOLT, WASHER BASED	墊圈座帽螺栓	1	28			
7	95607-10200	NUT, SELF-LOCKING	U型螺帽	1	5			
8	4CW-E5317-00	SPACER, ENGINE MOUNT	隔筒	1	70			
9	99009-17400	CIRCLIP	夾環	2	5			
10	95827-10025	BOLT.FLG	凸緣螺栓	4	5			
11	4CW-F7114-00	STOPPER, MAIN STAND	停止器	2	7			
12	5CA-F7114-00	STOPPER, MAIN STAND	停止器	1	10			
13	5CA-F1521-00	FLAP, FRONT FENDER	前檔泥蓋襟翼	1	100			
14	90464-15840	CLAMP	夾	2	15			
15	90480-18276	GROMMET	索環	1	7			
16	90480-01141	GROMMET	索環	2	3			
17	4TE-F8100-00	TOOL KIT	工具包	1	55			

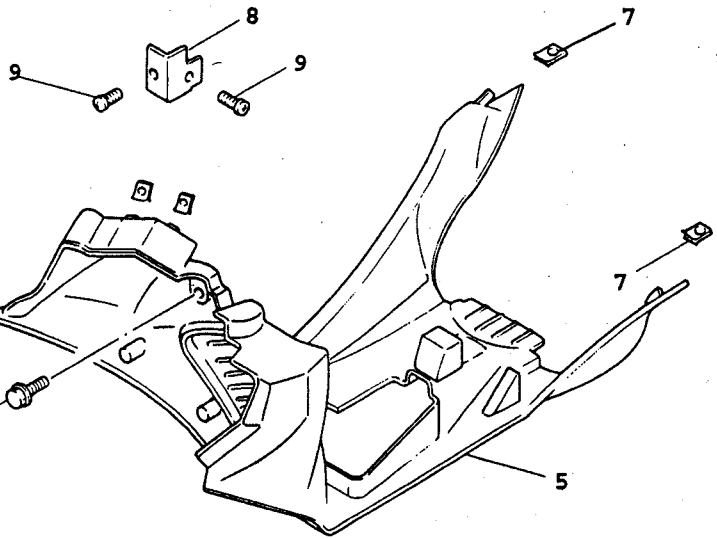
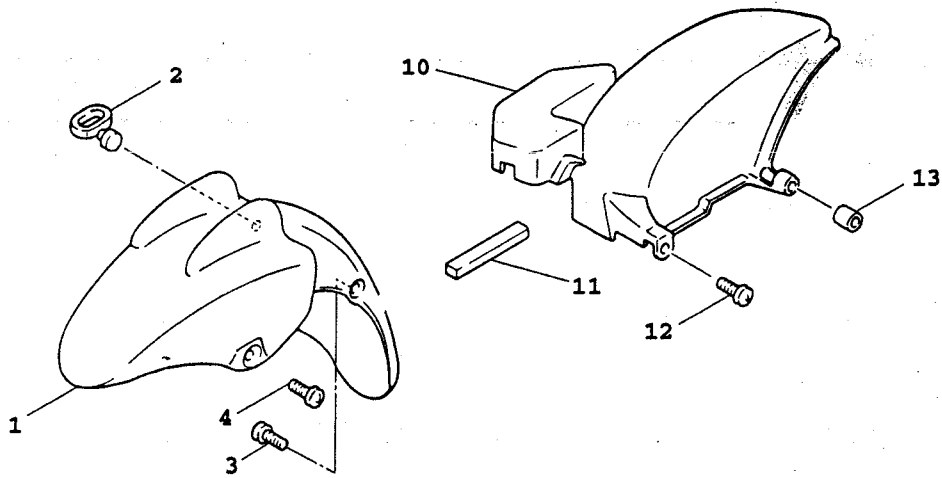

5CA1414-8151

FIG. 15 前擋泥蓋 YP125D(5CA4)

項次	部品番號	英文名稱	中文名稱	用量	建議價格	備註	代碼	工時
1	5CA-F1511-01-P7	FENDER, FRONT	前擋泥蓋	1	420	用於藍車 5CA4		
	5CA-F1511-01-1V	FENDER, FRONT	前擋泥蓋	1	420	用於銀車		
2	1MH-F1518-00	HOLDER, CABLE	鋼索固定環	1	20			
3	90154-06807	SCREW, BINDING	螺絲	2	5			
4	90109-06876	BOLT	螺栓	2	5			
5	5CA-F1552-00	FENDER, INNER	下前擋泥蓋	1	300			
6	90119-06821	BOLT, WITH WASHER	六角套頭螺栓	1	5			
7	90183-05807	NUT, SPRING	彈簧螺帽	4	5			
8	5CA-F1523-00	PLATE 1	擋泥蓋葉片	1	30			
9	97707-50016	SCREW, TAPPING	攻螺絲	2	3			
10	5CA-F1611-00	FENDER, REAR	後擋泥蓋	1	90			
11	5CA-F1639-00	DAMPER 2	防震墊	1	5			
12	98507-06014	SCREW, PAN HEAD	盤頭螺絲	2	3			
13	90387-062M9	COLLAR	軸環	2	5			

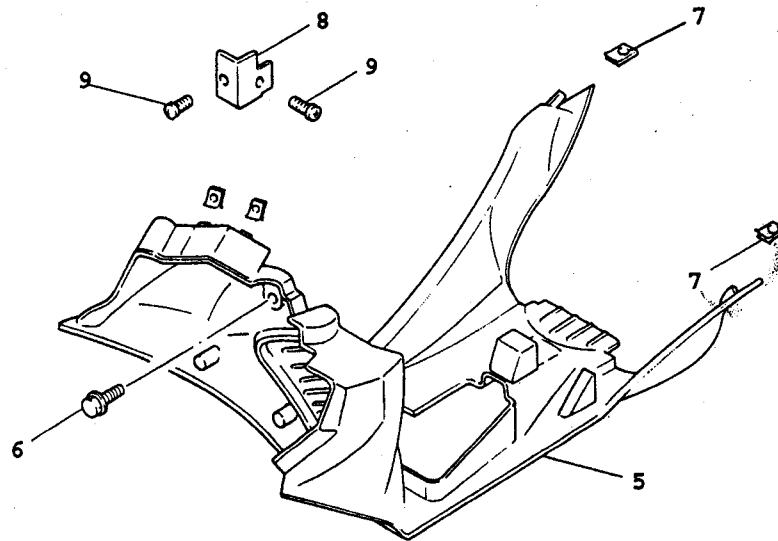
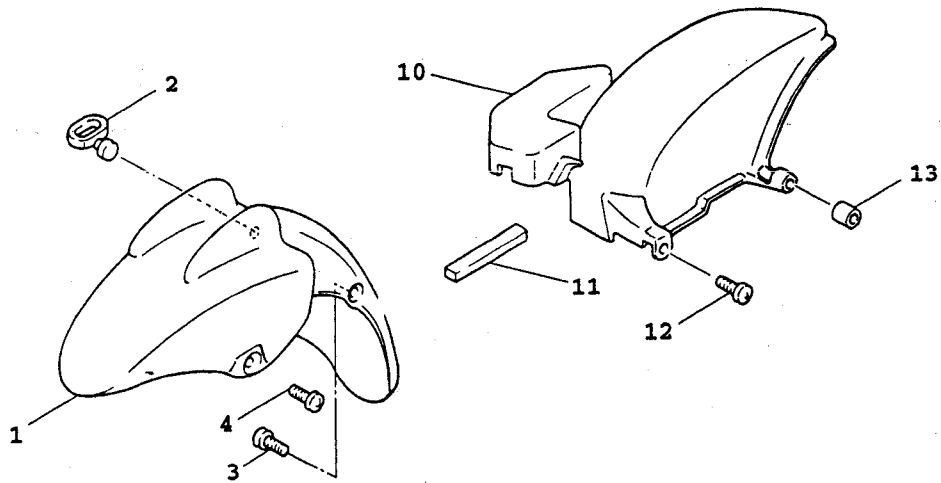

5CA1414-8151

FIG. 16 前擋泥蓋 YP125C(5CA7)

項次	部品番號	英文名稱	中文名稱	用量	建議價格	備註	代碼	工時
1	5CA-F1511-01-P6	FENDER, FRONT	前擋泥蓋	1	420	用於黑車	5CA7	
	5CA-F1511-01-1V	FENDER, FRONT	前擋泥蓋	1	420	用於銀車		
	5CA-F1511-01-P4	FENDER, FRONT	前擋泥蓋	1	420	用於深綠車		
2	1MH-F1518-00	HOLDER, CABLE	鋼索固定環	1	20			
3	90154-06807	SCREW, BINDING	螺絲	2	5			
4	90109-06876	BOLT	螺栓	2	5			
5	5CA-F1552-00	FENDER, INNER	下前擋泥蓋	1	300			
6	90119-06821	BOLT, WITH WASHER	六角套頭螺栓	1	5			
7	90183-05807	NUT, SPRING	彈簧螺帽	4	5			
8	5CA-F1523-00	PLATE 1	擋泥蓋葉片	1	30			
9	97707-50016	SCREW, TAPPING	攻螺絲	2	3			
10	5CA-F1611-00	FENDER, REAR	後擋泥蓋	1	90			
11	5CA-F1639-00	DAMPER 2	防震墊	1	5			
12	98507-06014	SCREW, PAN HEAD	盤頭螺絲	2	3			
13	90387-062M9	COLLAR	軸環	2	5			

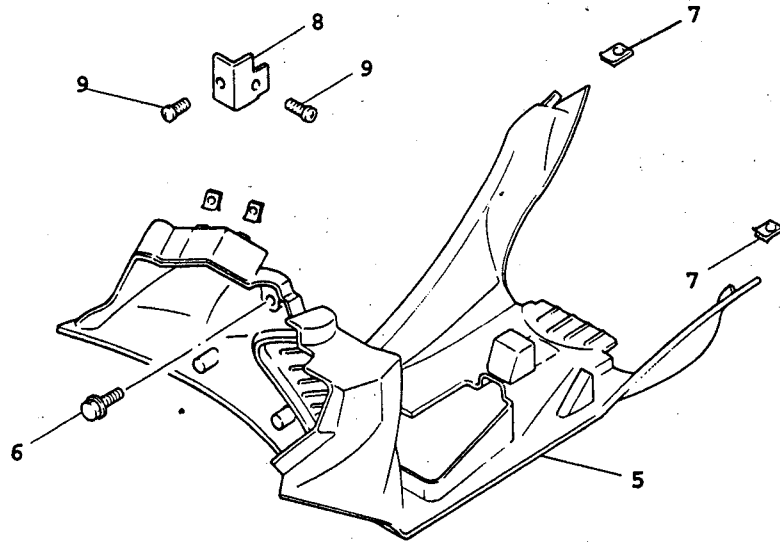
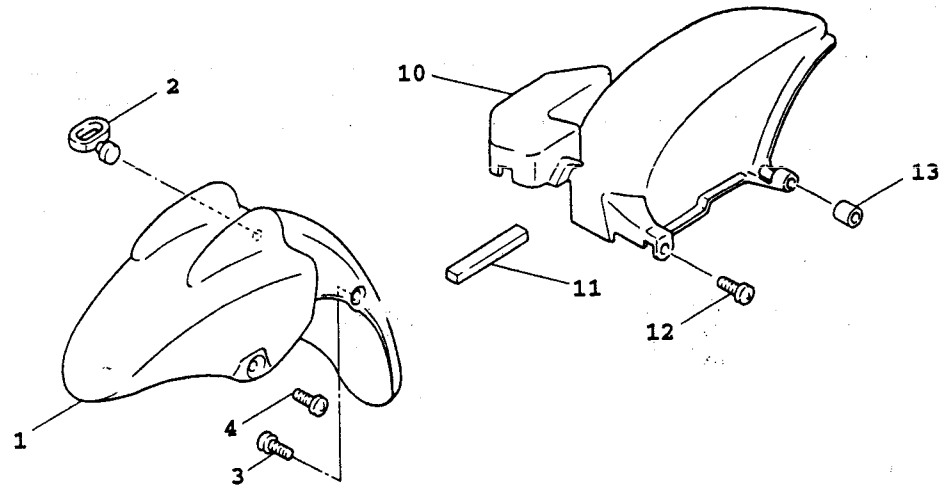

5CA1414-8151

FIG. 17 前擋泥蓋 YP125A(5CA8)

項次	部品番號	英文名稱	中文名稱	用量	建議價格	備註	代碼	工時
1	5CA-F1511-01-4B	FENDER, FRONT	前擋泥蓋	1	420	用於黑車	5CA8	
	5CA-F1511-01-1V	FENDER, FRONT	前擋泥蓋	1	420	用於銀車		
2	1MH-F1518-00	HOLDER, CABLE	鋼索固定環	1	20			
3	90154-06807	SCREW, BINDING	螺絲	2	5			
4	90109-06876	BOLT	螺栓	2	5			
5	5CA-F1552-00	FENDER, INNER	下前擋泥蓋	1	300			
6	90119-06821	BOLT, WITH WASHER	六角套頭螺栓	1	5			
7	90183-05807	NUT, SPRING	彈簧螺帽	4	5			
8	5CA-F1523-00	PLATE 1	擋泥蓋葉片	1	30			
9	97707-50016	SCREW, TAPPING	攻螺絲	2	3			
10	5CA-F1611-00	FENDER, REAR	後擋泥蓋	1	90			
11	5CA-F1639-00	DAMPER 2	防震墊	1	5			
12	98507-06014	SCREW, PAN HEAD	盤頭螺絲	2	3			
13	90387-062M9	COLLAR	軸環	2	5			

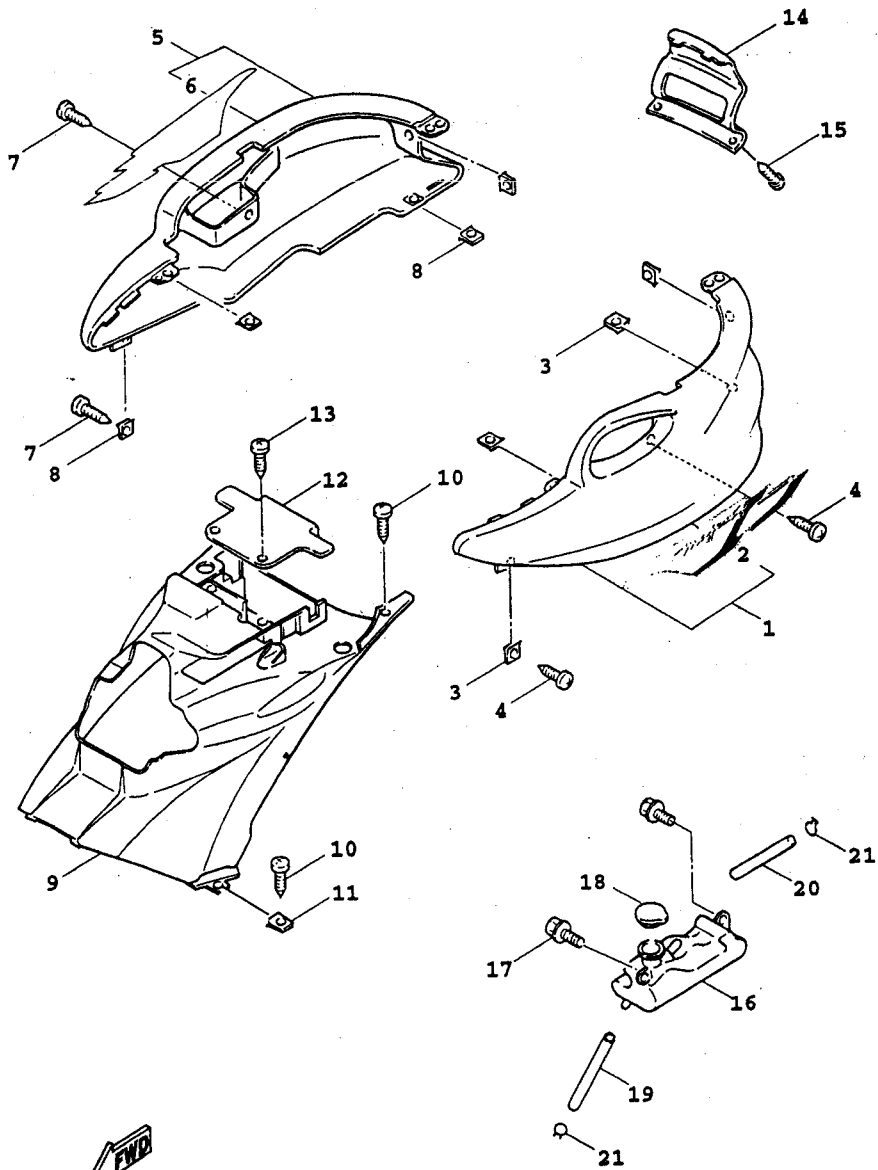

SCA4414-0180

FIG. 18 側蓋 YP125D(5CA4)

項次	部品番號	英文名稱	中文名稱	用量	建議價格	備註	代碼	工時
1	5CA-X2171-00-P7	SIDE COVER 1	側蓋 1	1	850	用於藍車	5CA4	
	5CA-X2171-20-1V	SIDE COVER 1	側蓋 1	1	850	用於銀車		
2	5CA-F1786-00	.EMBLEM 6	標誌	1		用於藍車		
	5CA-F1786-10	.EMBLEM 6	標誌	1		用於銀車		
3	90183-05807	NUT, SPRING	彈簧螺帽	4	5			
4	97707-50016	SCREW, TAPPING	攻螺絲	3	3			
5	5CA-X2172-00-P7	SIDE COVER 2	側蓋 2	1	850	用於藍車		
	5CA-X2172-20-1V	SIDE COVER 2	側蓋 2	1	850	用於銀車		
6	5CA-F1787-00	.EMBLEM 7	標誌	1		用於藍車		
	5CA-F1787-10	.EMBLEM 7	標誌	1		用於銀車		
7	97707-50016	SCREW, TAPPING	攻螺絲	2	3			
8	90183-05807	NUT, SPRING	彈簧螺帽	4	5			
9	5CA-F1731-00	COVER, SIDE 3	側蓋 3	1	160			
10	97707-50016	SCREW, TAPPING	攻螺絲	4	3			
11	90183-05807	NUT, SPRING	彈簧螺帽	2	5			
12	5CA-H2129-00	COVER, BATTERY	蓄電池蓋	1	30			
13	97707-50016	SCREW, TAPPING	攻螺絲	2	3			
14	5CA-F1741-00-P7	COVER, SIDE 4	側蓋 4	1	160	用於藍車		
	5CA-F1741-00-1V	COVER, SIDE 4	側蓋 4	1	160	用於銀車		

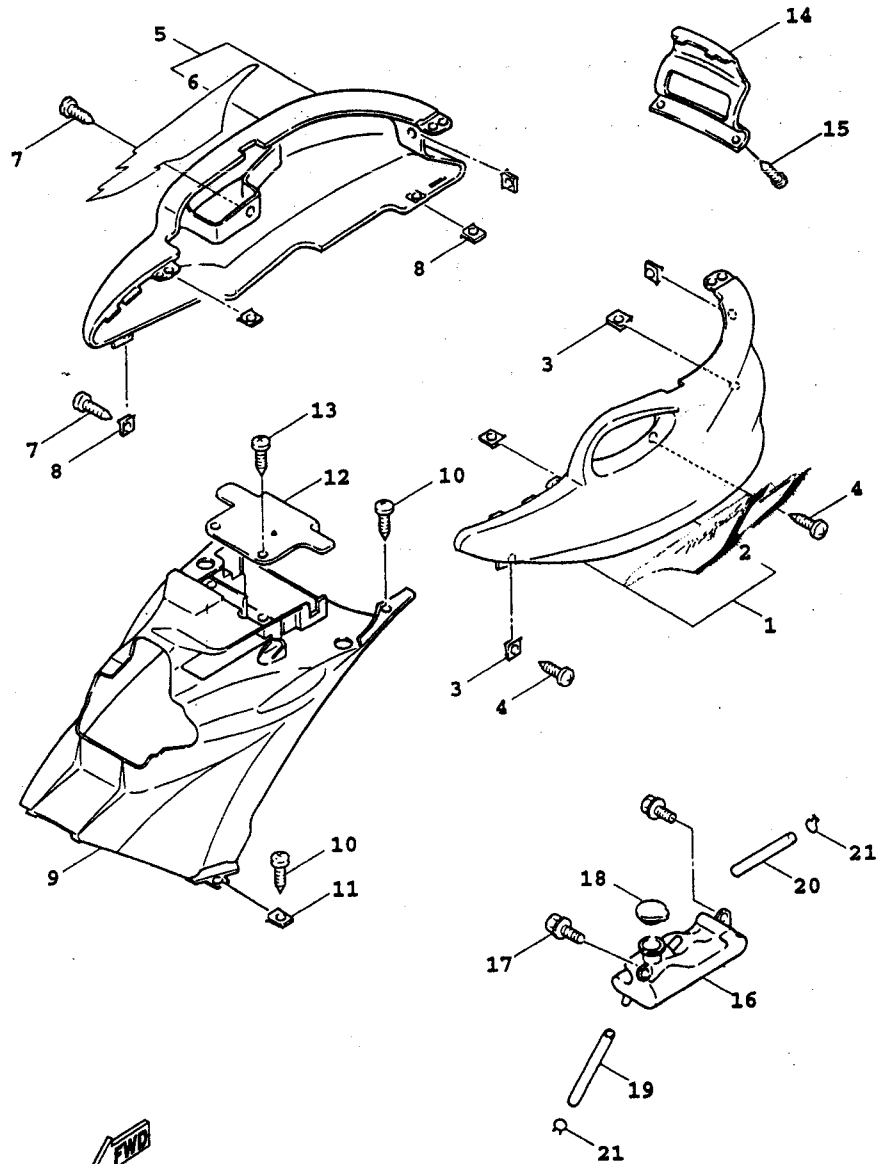

5CA4414-0180

FIG. 18 側蓋 YP125D(5CA4)

項次	部品番號	英文名稱	中文名稱	用量	建議價格	備註	代碼	工時
15	97707-50016	SCREW, TAPPING	攻螺絲	2	3			
16	5CA-F1871-00	TANK, RECOVERY	輔助水箱	1	75			
17	90159-06813	SCREW, WITH WASHER	螺絲附墊圈	2	3			
18	5CA-F1815-00	CAP	輔助水箱蓋	1	15			
19	90445-098B1	HOSE	管	1	20			
20	90445-09104	HOSE	管	1	10			
21	90467-09006	CLIP	止夾	2	5			

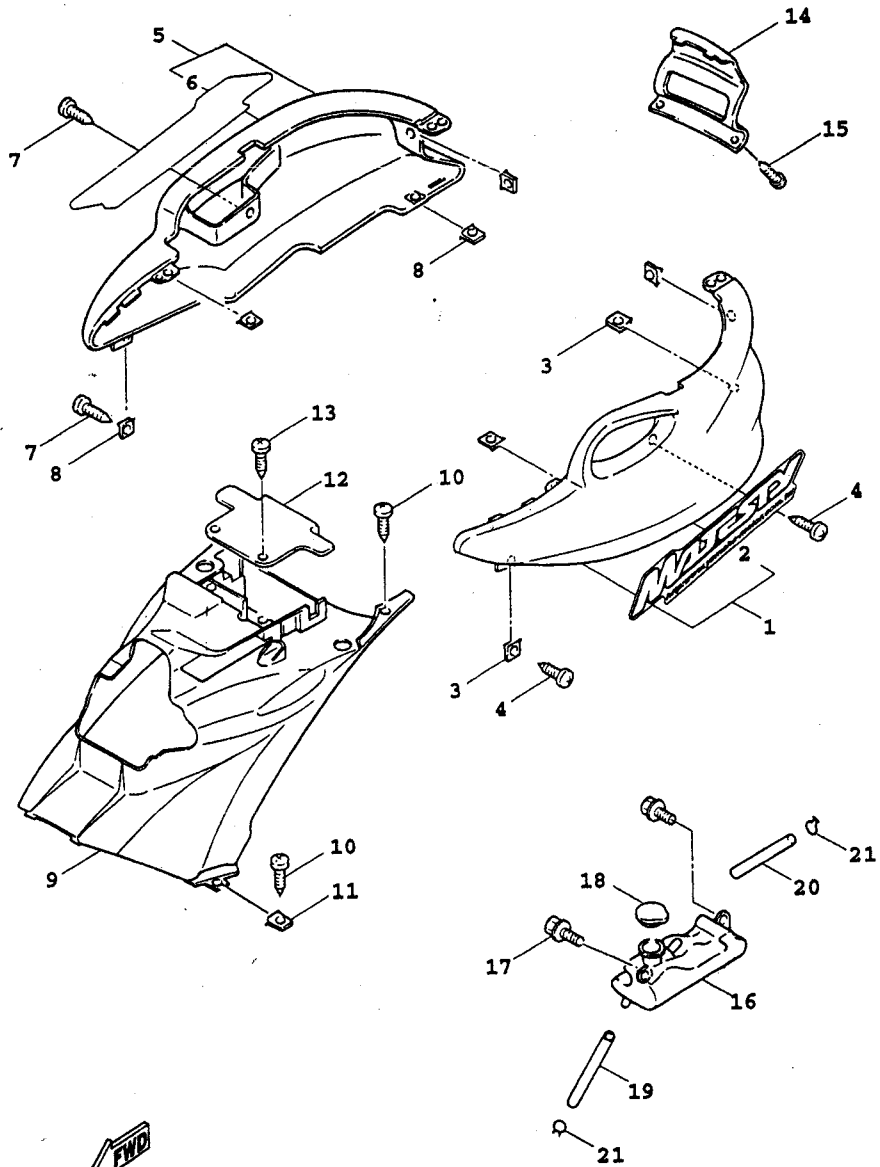

5CA7414-0190

FIG. 19 側蓋 YP125C(5CA7)

項次	部品番號	英文名稱	中文名稱	用量	建議價格	備註	代碼	工時
1	5CA-X2171-00-P6	SIDE COVER 1	側蓋 1	1	850	用於黑車	5CA7	
	5CA-X2171-30-1V	SIDE COVER 1	側蓋 1	1	850	用於銀車		
	5CA-X2171-30-P4	SIDE COVER 1	側蓋 1	1	850	用於深綠車		
2	5CA-F1785-00	.EMBLEM 5	標誌	1		用於黑車		
	5CA-F1785-10	.EMBLEM 5	標誌	1		用於銀車		
	5CA-F1785-20	.EMBLEM 5	標誌	1		用於深綠車		
3	90183-05807	NUT, SPRING	彈簧螺帽	4	5			
4	97707-50016	SCREW, TAPPING	攻螺絲	3	3			
5	5CA-X2172-00-P6	SIDE COVER 2	側蓋 2	1	850	用於黑車		
	5CA-X2172-30-1V	SIDE COVER 2	側蓋 2	1	850	用於銀車		
	5CA-X2172-30-P4	SIDE COVER 2	側蓋 2	1	850	用於深綠車		
6	5CA-F1785-00	.EMBLEM 5	標誌	1		用於黑車		
	5CA-F1785-10	.EMBLEM 5	標誌	1		用於銀車		
	5CA-F1785-20	.EMBLEM 5	標誌	1		用於深綠車		
7	97707-50016	SCREW, TAPPING	攻螺絲	2	3			
8	90183-05807	NUT, SPRING	彈簧螺帽	4	5			
9	5CA-F1731-00	COVER, SIDE 3	側蓋 3	1	160			
10	97707-50016	SCREW, TAPPING	攻螺絲	4	3			
11	90183-05807	NUT, SPRING	彈簧螺帽	2	5			

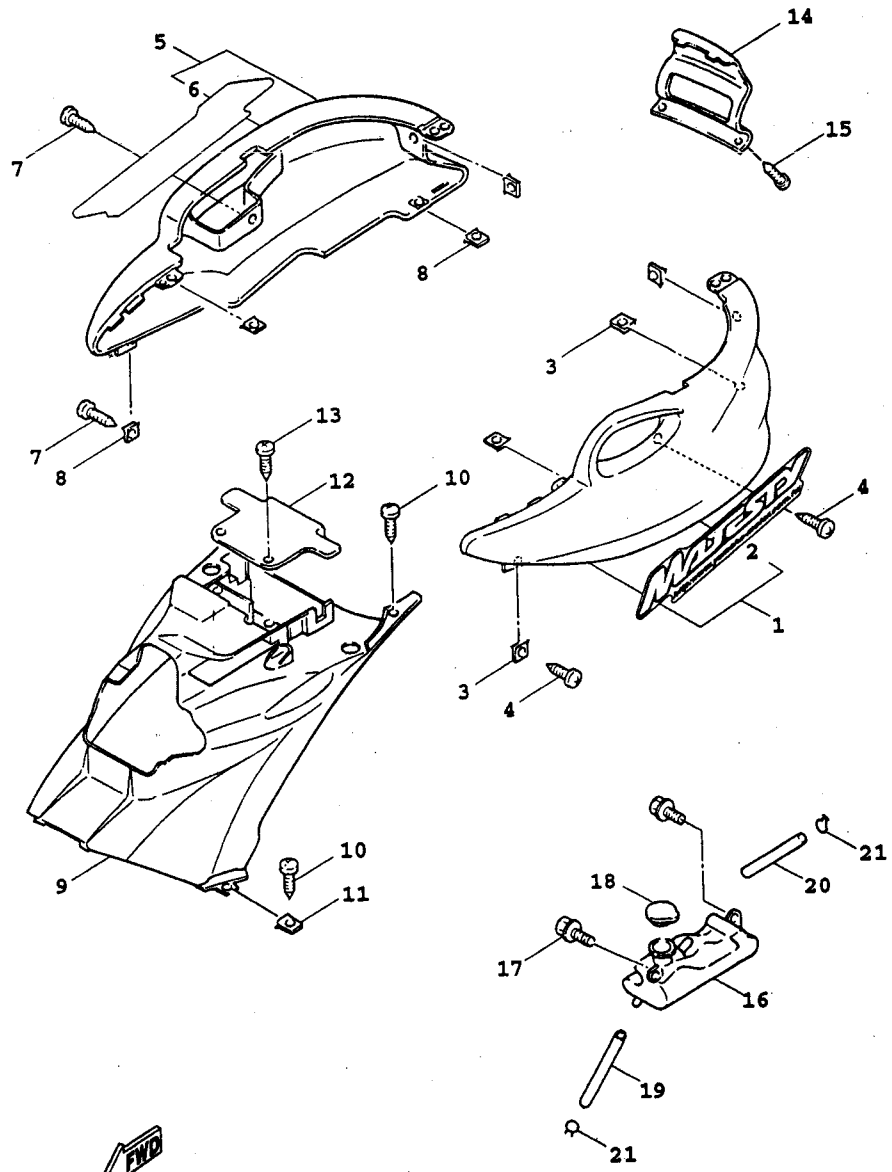

5CA7414-0190

FIG. 19 側蓋 YP125C(5CA7)

項次	部品番號	英文名稱	中文名稱	用量	建議價格	備註	代碼	工時
12	5CA-H2129-00	COVER, BATTERY	蓄電池蓋	1	30			
13	97707-50016	SCREW, TAPPING	攻螺絲	2	3			
14	5CA-F1741-00-P6	COVER, SIDE 4	側蓋 4	1	160	用於黑車		
	5CA-F1741-00-1V	COVER, SIDE 4	側蓋 4	1	160	用於銀車		
	5CA-F1741-00-P4	COVER, SIDE 4	側蓋 4	1	160	用於深綠車		
15	97707-50016	SCREW, TAPPING	攻螺絲	2	3			
16	5CA-F1871-00	TANK, RECOVERY	輔助水箱	1	75			
17	90159-06813	SCREW, WITH WASHER	螺絲附墊圈	2	3			
18	5CA-F1815-00	CAP	輔助水箱蓋	1	15			
19	90445-098B1	HOSE	管	1	20			
20	90445-09104	HOSE	管	1	10			
21	90467-09006	CLIP	止夾	2	5			

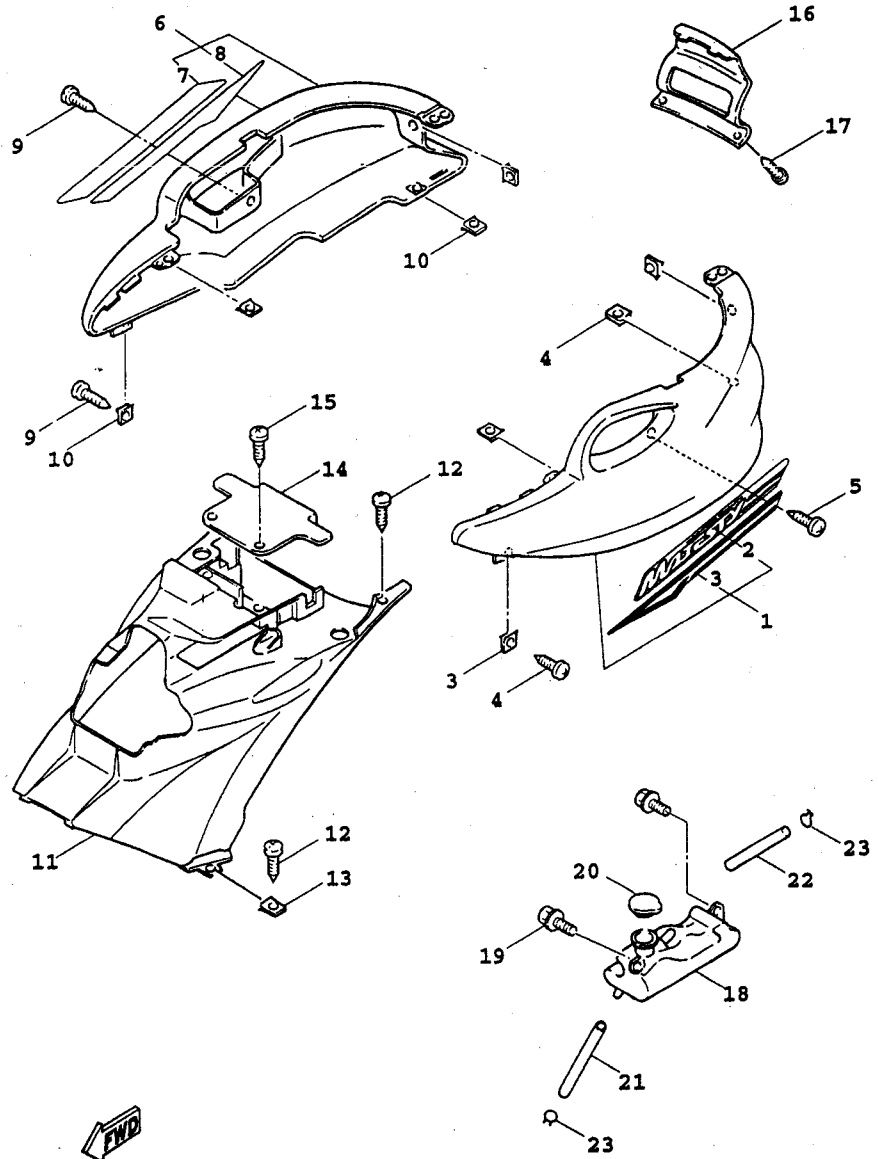

5CA8414-0200

FIG. 20 側蓋 YP125A(5CA8)

項次	部品番號	英文名稱	中文名稱	用量	建議價格	備註	代碼	工時
1	5CA-X2171-20-4B	SIDE COVER 1	側蓋 1	1	850	用於黑車	5CA8	
	5CA-X2171-40-1V	SIDE COVER 1	側蓋 1	1	850	用於銀車		
2	5CA-F174G-00	.GRAPHIC 3	圖案	1		用於黑車		
	5CA-F174G-10	.GRAPHIC 3	圖案	1		用於銀車		
3	5CA-F174H-00	.GRAPHIC 4	圖案	1		用於黑車		
	5CA-F174H-10	.GRAPHIC 4	圖案	1		用於銀車		
4	90183-05807	NUT, SPRING	彈簧螺帽	4	5			
5	97707-50016	SCREW, TAPPING	攻螺絲	3	3			
6	5CA-X2172-20-4B	SIDE COVER 2	側蓋 2	1	850	用於黑車		
	5CA-X2172-40-1V	SIDE COVER 2	側蓋 2	1	850	用於銀車		
7	5CA-F174J-00	.GRAPHIC 5	圖案	1		用於黑車		
	5CA-F174J-10	.GRAPHIC 5	圖案	1		用於銀車		
8	5CA-F174K-00	.GRAPHIC 6	圖案	1		用於黑車		
	5CA-F174K-10	.GRAPHIC 6	圖案	1		用於銀車		
9	97707-50016	SCREW, TAPPING	攻螺絲	2	3			
10	90183-05807	NUT, SPRING	彈簧螺帽	4	5			
11	5CA-F1731-00	COVER, SIDE 3	側蓋 3	1	160			
12	97707-50016	SCREW, TAPPING	攻螺絲	4	3			
13	90183-05807	NUT, SPRING	彈簧螺帽	2	5			

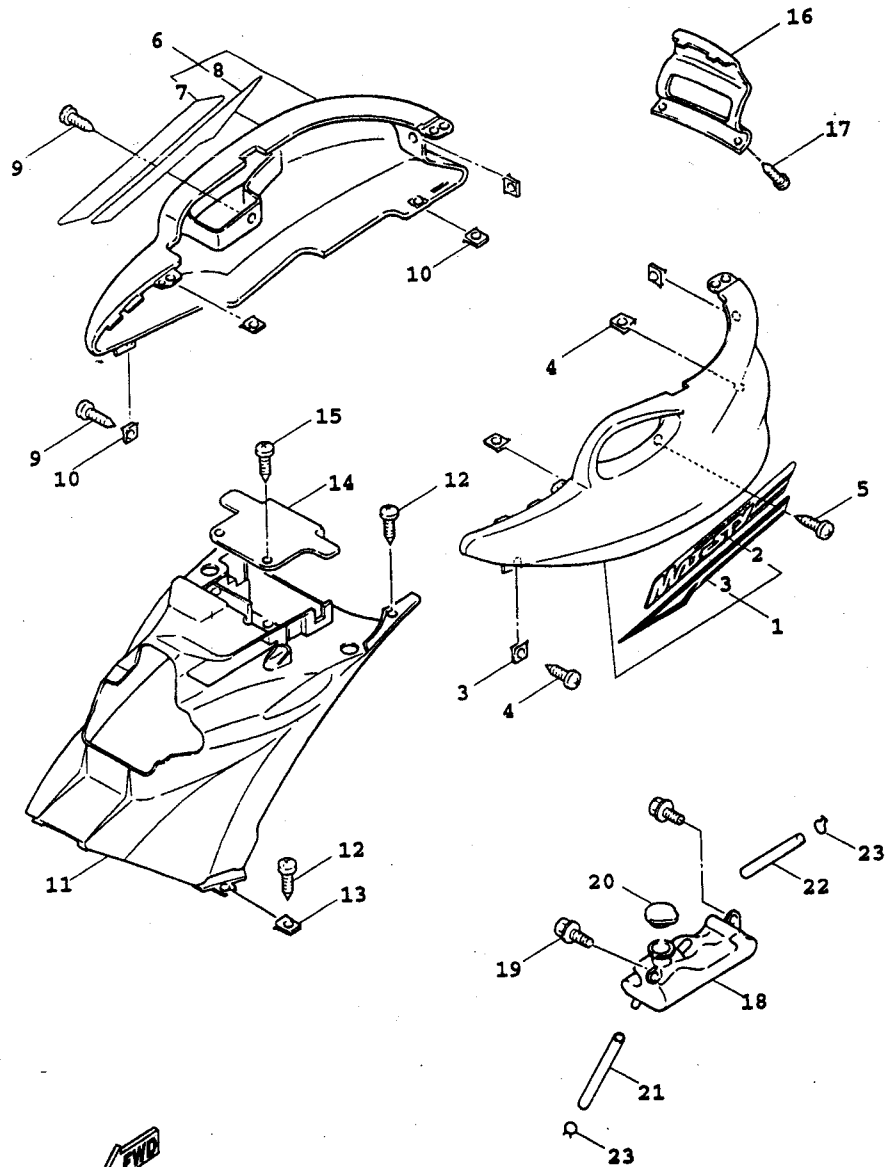

5CA8414-0200

FIG. 20 側蓋 YP125A(5CA8)

項次	部品番號	英文名稱	中文名稱	用量	建議價格	備註	代碼	工時
14	5CA-H2129-00	COVER, BATTERY	蓄電池蓋	1	30			
15	97707-50016	SCREW, TAPPING	攻螺絲	2	3			
16	5CA-F1741-00-4B	COVER, SIDE 4	側蓋 4	1	160	用於黑車		
	5CA-F1741-00-1V	COVER, SIDE 4	側蓋 4	1	160	用於銀車		
17	97707-50016	SCREW, TAPPING	攻螺絲	2	3			
18	5CA-F1871-00	TANK, RECOVERY	輔助水箱	1	75			
19	90159-06813	SCREW, WITH WASHER	螺絲附墊圈	2	3			
20	5CA-F1815-00	CAP	輔助水箱蓋	1	15			
21	90445-098B1	HOSE	管	1	20			
22	90445-09104	HOSE	管	1	10			
23	90467-09006	CLIP	止夾	2	5			

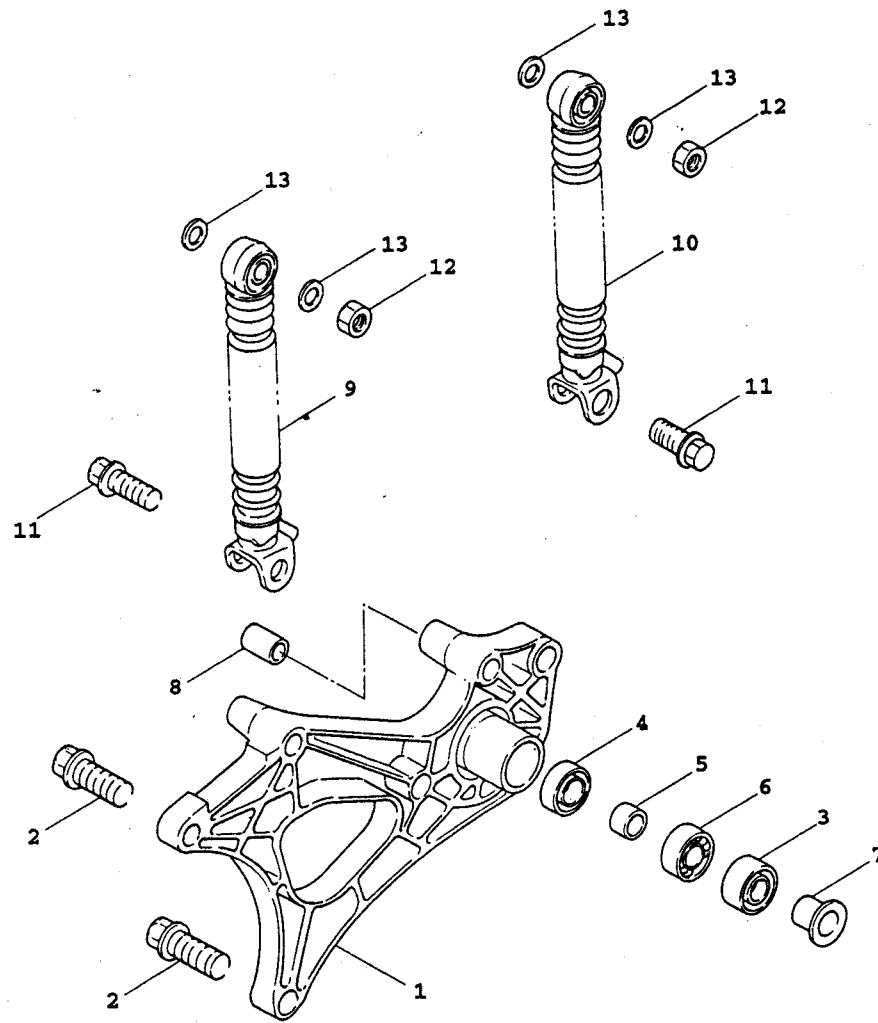

5CA1414-8170

FIG. 21 後臂，懸吊系統

項次	部品番號	英文名稱	中文名稱	用量	建議價格	備註	代碼	工時
1	5CA-F2171-10	ARM, REAR 1	後臂	1	650			
2	95827-08045	BOLT, FLG	凸緣螺栓	2	5			
3	93109-28811	SEAL, OIL	油封	1	8			
4	93106-26823	SEAL, OIL	油封	1	10			
5	90387-15423	COLLAR	軸環	1	15			
6	93306-302X1	BRG.	軸承	1	75			
7	90387-153N8	COLLAR	軸環	1	30			
8	4X6-F2216-00	BUSH, REAR SHOCK ABSORBER	後緩衝器襯套	1	11			
9	5CA-F2210-00	SHOCK ABSORBER ASSY, REAR	後緩衝器	1	600			
10	5CA-F2220-00	SHOCK ABSORBER ASSY, REAR	後緩衝器	1	600			
11	90105-08121	BOLT, WASHER BASED	墊圈座帽螺栓	2	5			
12	95707-10500	NUT, FLG	凸緣螺帽	2	5			
13	90201-105A2	WASHER, PLATE	平墊圈	4	5			

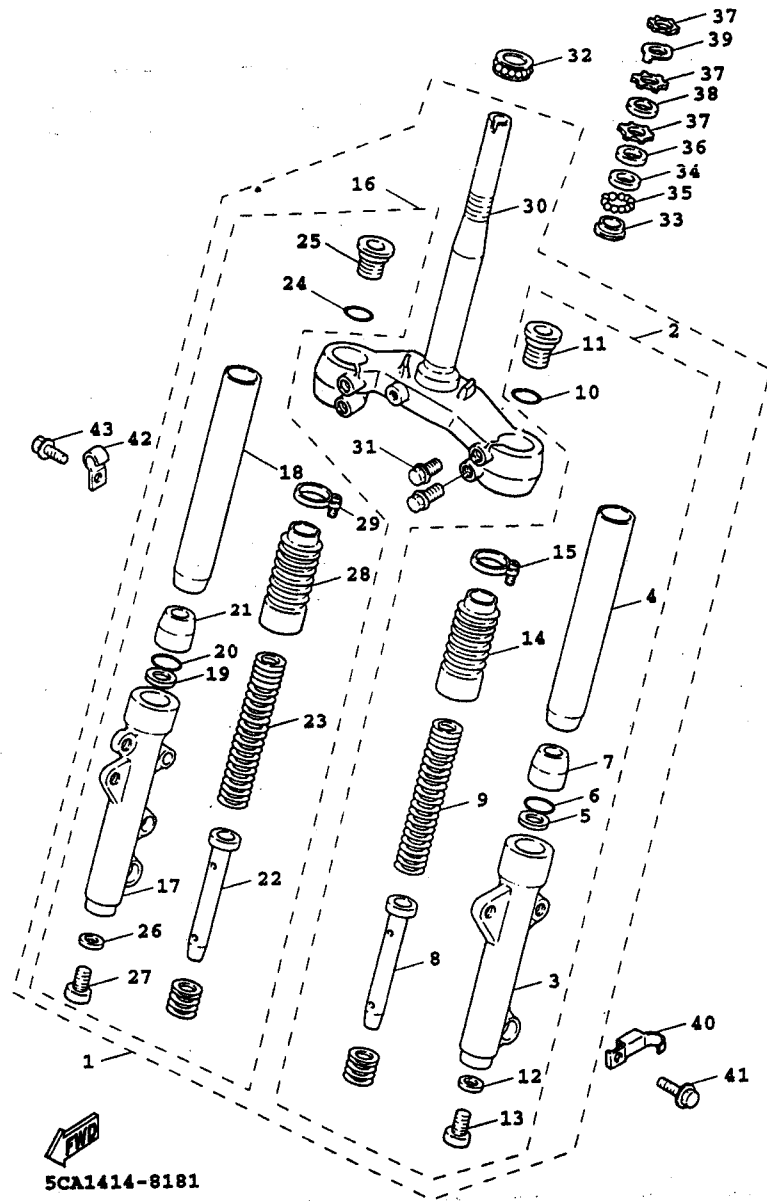

5CA1414-8181

FIG. 22 前叉

項次	部品番號	英文名稱	中文名稱	用量	建議價格	備註	代碼	工時
1	5CA-F3100-10-1V	FRONT FORK ASSY	前叉總成	1	4,300			
2	5CA-F3102-10-1V	.FRONT FORK ASSY (L.H)	左前叉內外管組	1	1,600			
3	5CA-F3126-10-1V	..TUBE, OUTER 1	左外管	1	650			
4	5CA-F3110-00	..INNER TUBE COMP.1	前叉內管	1	430			
5	3UH-F3145-00	..OIL SEAL	油封	1	40			
6	3UH-F3153-00	..RING, SNAP	環	1	7			
7	3UH-F3173-00	..SPINDLE, TAPER	錐形心軸	1	25			
8	5CA-F3170-00	..CYLINDER COMP.,	前叉接筒整體	1	145			
9	5CA-F3141-00	..SPRING, FRONT FORK	前叉彈簧	1	50			
10	3UR-F3147-00	..O-RING	護油圈	1	5			
11	4HP-F3111-00	..BOLT, CAP	頂蓋螺栓	1	74			
12	3UR-F3158-00	..GASKET	墊片	1	5			
13	3UR-F3181-00	..BOLT, HEXAGON SOCKET HEAD	螺栓	1	10			
14	3UH-F3191-00	..BOOT	保護罩	1	100			
15	3UH-F3192-00	..BAND	保護罩帶	1	9			
16	5CA-F3103-10-1V	.FRONT FORK ASSY (R.H)	右前叉內外管組	1	1,600			
17	5CA-F3136-10-1V	..TUBE, OUTER 2	右外管	1	650			
18	5CA-F3110-00	..INNER TUBE COMP.1	前叉內管	1	430			
19	3UH-F3145-00	..OIL SEAL	油封	1	40			

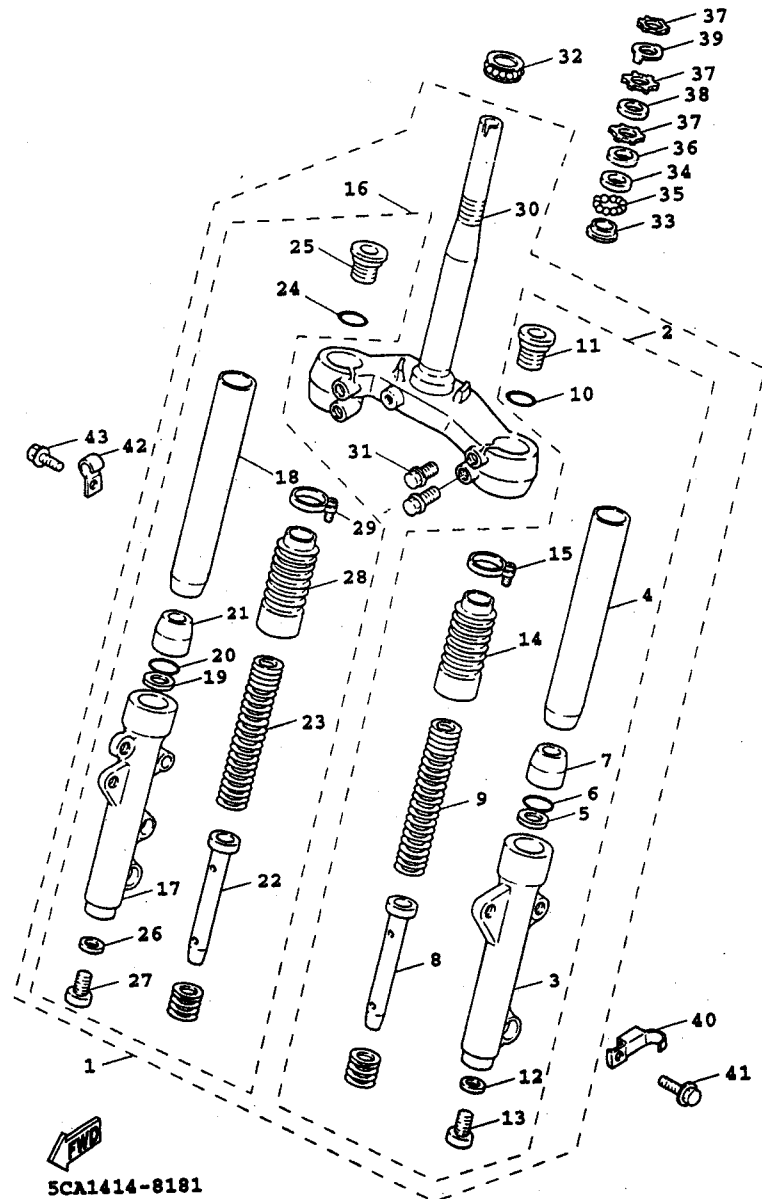

5CA1414-8181

FIG. 22 前叉

項次	部品番號	英文名稱	中文名稱	用量	建議價格	備註	代碼	工時
20	3UH-F3153-00	..RING, SNAP	環	1	7			
21	3UH-F3173-00	..SPINDLE, TAPER	錐形心軸	1	25			
22	5CA-F3170-00	..CYLINDER COMP.,	前叉接筒整體	1	145			
23	5CA-F3141-00	..SPRING, FRONT FORK	前叉彈簧	1	50			
24	3UR-F3147-00	..O-RING	護油圈	1	5			
25	4HP-F3111-00	..BOLT, CAP	頂蓋螺栓	1	74			
26	3UR-F3158-00	..GASKET	墊片	1	5			
27	3UR-F3181-00	..BOLT, HEXAGON SOCKET HEAD	螺栓	1	10			
28	3UH-F3191-00	..BOOT	保護罩	1	100			
29	3UH-F3192-00	..BAND	保護罩帶	1	9			
30	5CA-F3340-00	.UNDER BRACKET COMP.	下三角架	1	1,300			
31	5CA-F3346-00	.BOLT 1	螺栓	4	10			
32	93399-99940	BEARING	軸承	1	1,140			
33	22F-23412-01	RACE, BALL 2	珠碗 2	1	100			
34	22F-23411-01	RACE, BALL 1	珠碗 1	1	100			
35	93503-16003	BALL	鋼珠	22	3			
36	4TE-F3416-00	COVER, BALL RACE 2	珠碗蓋	1	5			
37	90179-25615	NUT	螺帽	3	20			
38	90202-26142	WASHER, PLATE	平墊圈	1	5			

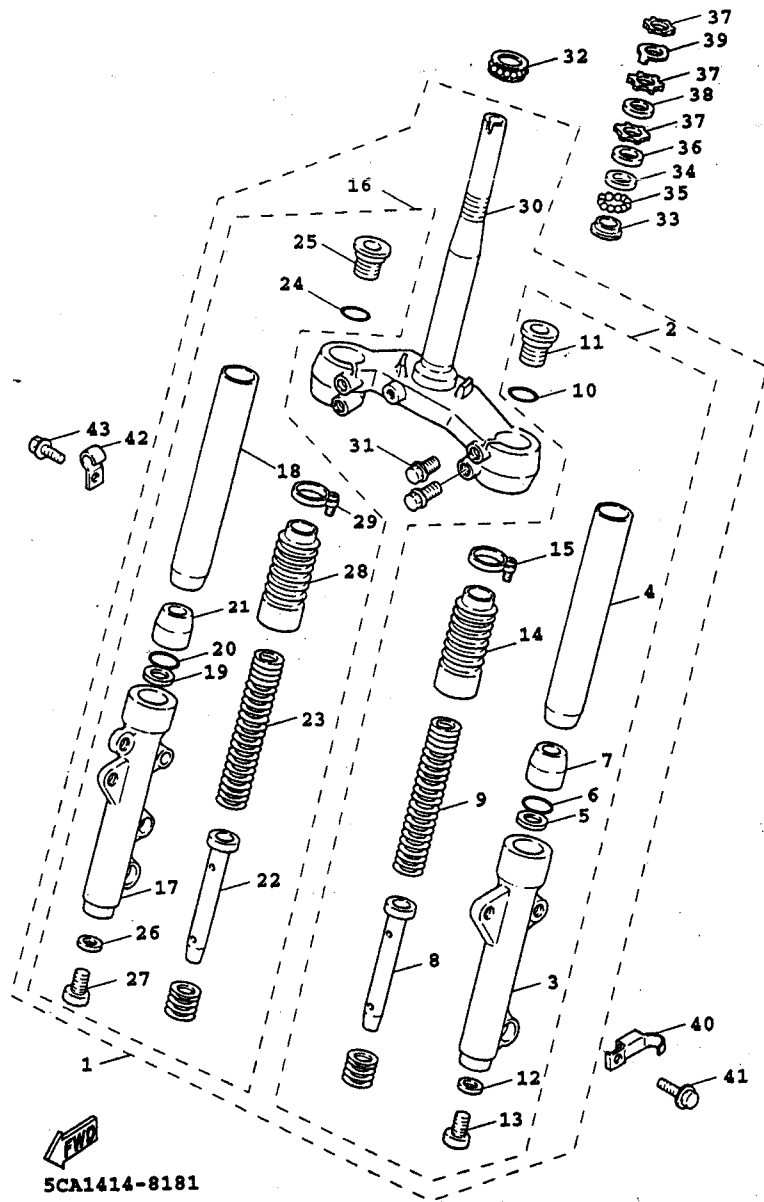

5CA1414-8181

FIG. 22 前叉

項次	部品番號	英文名稱	中文名稱	用量	建議價格	備註	代碼	工時
39	4VP-F3418-00	WASHER, SPECIAL	特殊墊圈	1	15			
40	5CA-F5875-00	HOLDER, BRAKE HOSE 1	剎車管座1	1	30			
41	95807-06012	BOLT, FLG	凸緣螺栓	1	3			
42	5CA-F5876-00	HOLDER, BRAKE HOSE 2	剎車管座2	1	15			
43	95807-06014	BOLT, FLG	凸緣螺栓	1	3			
44	5CA-W2341-00	RACE BALL KIT	珠碗組	1	1,340			

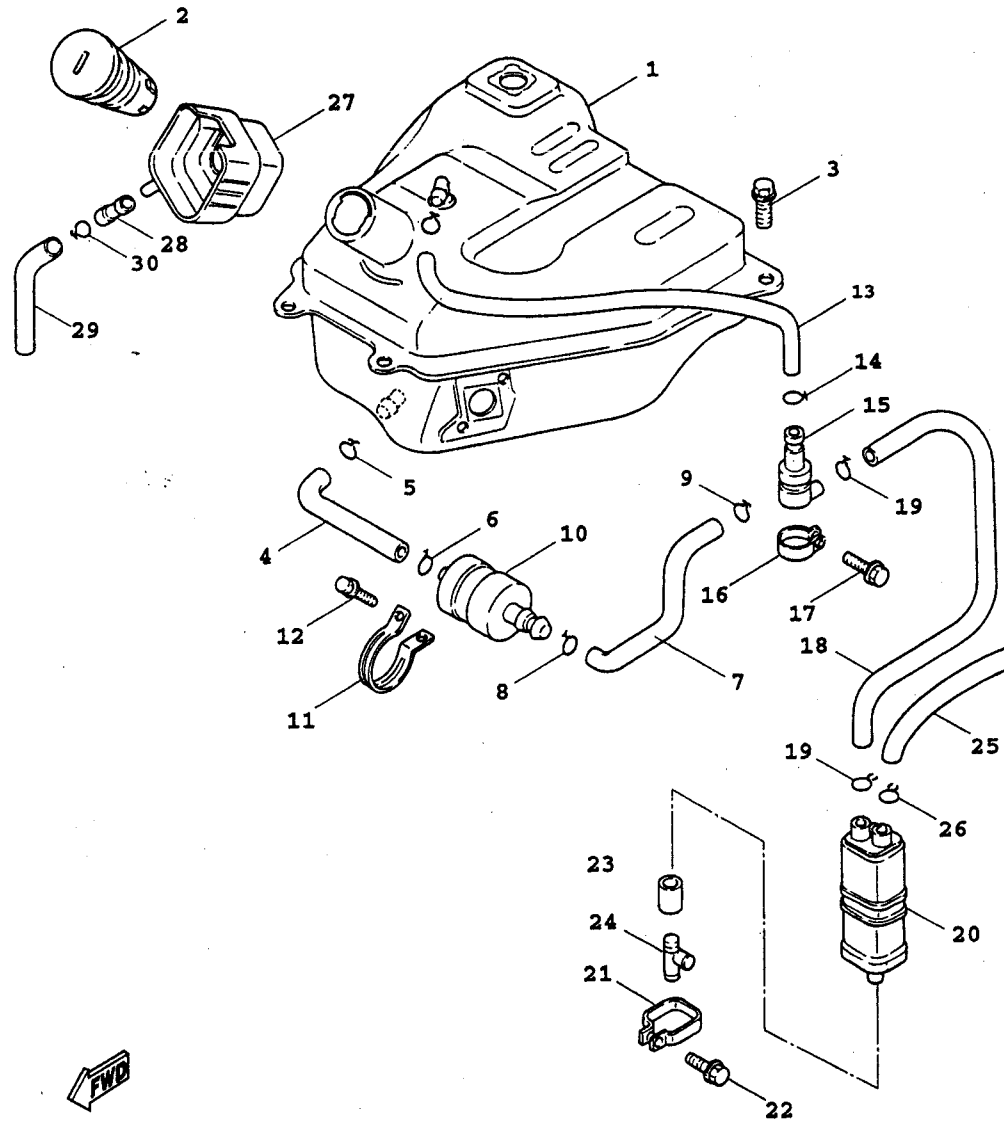

5CA1414-8190

FIG. 23 汽油箱

項次	部品番號	英文名稱	中文名稱	用量	建議價格	備註	代碼	工時
1	5CA-F4110-00-33	FUEL TANK COMP.	汽油箱總成	1	1,100	山葉黑色		
2	3UH-F4610-10	CAP ASSY	汽油箱蓋總成	1	200			
3	95807-06012	BOLT, FLG	凸緣螺栓	4	3			
4	5CA-F4311-00	PIPE, FUEL 1	汽油管	1	10			
5	90467-10041	CLIP	止夾	1	5			
6	90467-08003	CLIP	止夾	1	3			
7	90445-091K5	HOSE	管	1	5			
8	90467-08003	CLIP	止夾	1	3			
9	90467-09006	CLIP	止夾	1	5			
10	5CA-F4560-00	FILTER ASSY	過濾器	1	50			
11	5CA-F4568-00	BAND, FILTER	束帶	1	15			
12	95027-06010	BOLT, FLG	凸緣螺栓	1	5			
13	90445-098B2	HOSE	管	1	15			
14	90467-09006	CLIP	止夾	2	5			
15	3UH-F4180-02	ROLL OVER VALVE ASSY	控制閥總成	1	120			
16	90461-15801	CLAMP	夾環	1	33			
17	97607-05212	SCREW, W/WASHER	六角螺栓附墊圈	1	5			
18	5CA-F4314-00	PIPE 4	油管	1	15			
19	90467-09006	CLIP	止夾	2	5			

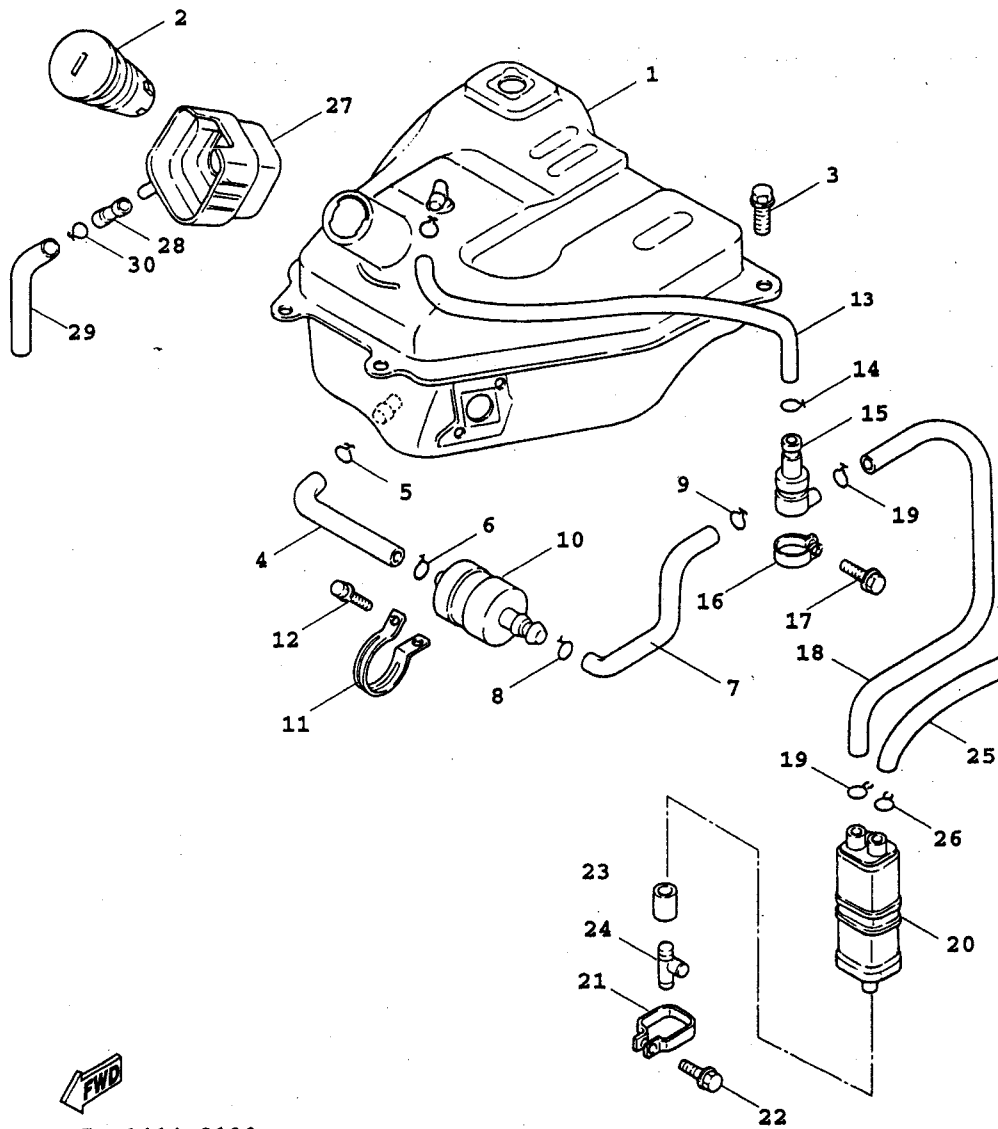

5CA1414-8190

FIG. 23 汽油箱

項次	部品番號	英文名稱	中文名稱	用量	建議價格	備註	代碼	工時
20	4JJ-F4170-01	CANISTER ASSY	活性碳罐	1	135			
21	5CA-F134X-00	BRACKET, CANISTER	支架	1	20			
22	90159-06813	SCREW, WITH WASHER	螺絲附墊圈	1	3			
23	90445-11865	HOSE	管	1	7			
24	3UH-F4376-00	PIPE, JOINT 1	連接管	1	29			
25	90445-098B3	HOSE	管	1	20			
26	90467-09006	CLIP	止夾	2	5			
27	5CA-F414A-00	COVER, FILLER	蓋	1	40			
28	4TE-F1753-00	BOSS, CONNECTOR	接頭	1	5			
29	91A10-07048	HOSE	管	1	15			
30	90464-23811	CLAMP	夾	1	7			

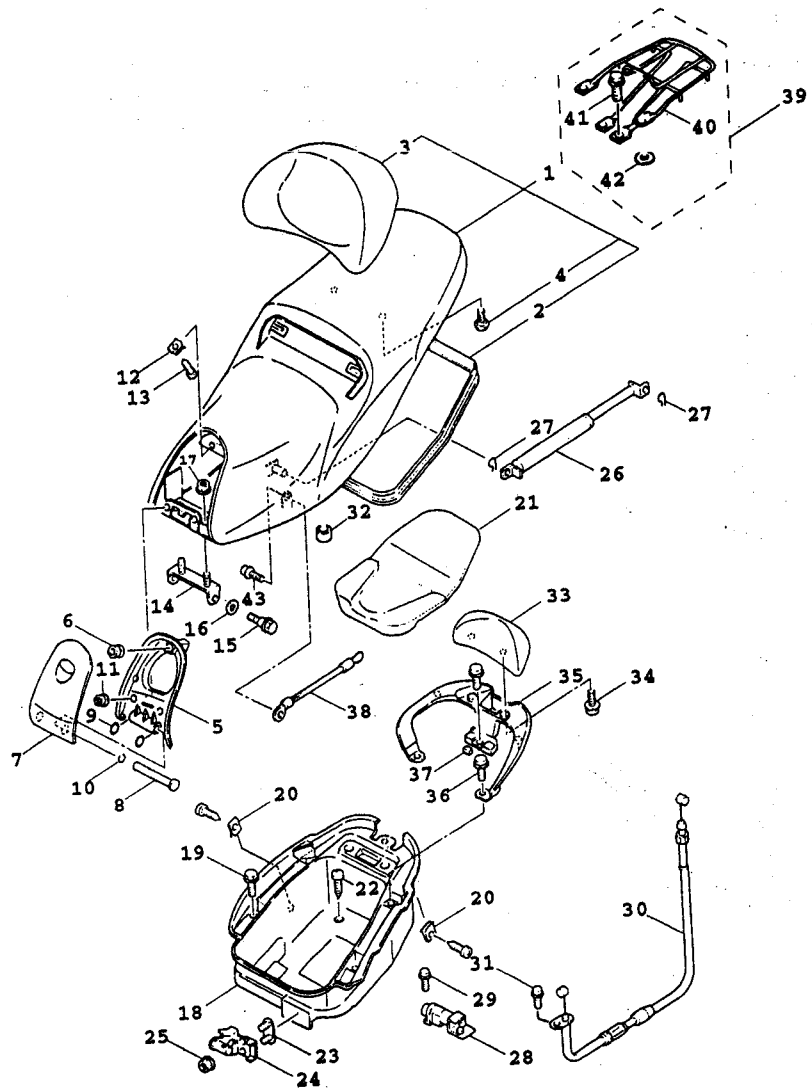

5CA1414-8201

FIG. 24 座墊

項次	部品番號	英文名稱	中文名稱	用量	建議價格	備註	代碼	工時
1	5CA-F4730-00	DOUBLE SEAT ASSY	雙人座墊	1	1,800			
2	5CA-F475M-00	.SEAL	封圈	1	130			
3	5CA-F4790-00	.SEAT BACK ASSY	靠背	1	410			
4	90149-06834	.SCREW	螺絲	2	5			
5	5CA-F473F-00	PANEL, FRONT	前嵌板	1	35			
6	90480-01884	GROMMET	索環	1	10			
7	5CA-F473T-00	LID 1	箱蓋	1	35			
8	90240-05047	PIN, CLEVIS	附孔銷	1	10			
9	93210-058H0	O-RING	護油圈	2	5			
10	90468-12007	CLIP	止夾	1	3			
11	98907-06010	SCREW, BIND HEAD	有帽螺絲	2	3			
12	90183-05807	NUT, SPRING	彈簧螺帽	1	5			
13	97707-50016	SCREW, TAPPING	攻螺絲	1	3			
14	5CA-F197J-00	HINGE 1	絞鏈1	1	50			
15	90109-06877	BOLT	螺栓	2	5			
16	90206-10808	WASHER, WAVE	波形墊圈	2	5			
17	95707-08500	NUT, FLG	凸緣螺帽	2	3			
18	5CA-F473R-00	BOX 1	置物箱	1	300			
19	90109-063F1	BOLT	螺栓	4	5			

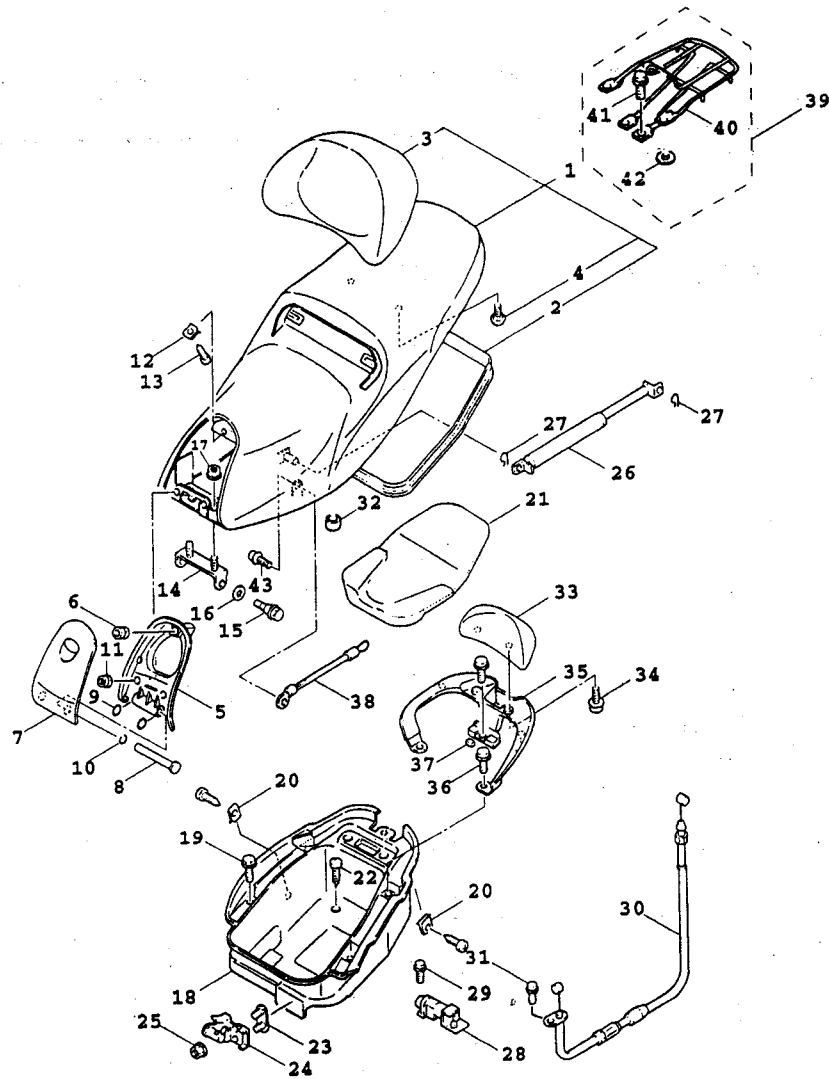

5CA1414-8201

FIG. 24 座墊

項次	部品番號	英文名稱	中文名稱	用量	建議價格	備註	代碼	工時
20	90183-05807	NUT, SPRING	彈簧螺帽	3	5			
21	5CA-F4723-00	DAMPER, SEAT	防震墊	1	150			
22	97707-50016	SCREW, TAPPING	攻螺絲	2	3			
23	5CA-F4766-00	REINF.	補強材	1	15			
24	5CA-F4738-00	BRACKET, SEAT	座墊卡架	1	35			
25	95707-06500	NUT, FLG	凸緣螺帽	2	3			
26	5CA-F478G-00	STOPPER	停止器	1	500			
27	90468-18121	CLIP	止夾	2	5			
28	4UE-F4780-02	SEAT LOCK ASSY	座墊鎖總成	1	125			
29	95807-06016	BOLT, FLG	凸緣螺栓	2	3			
30	5CA-F478E-00	WIRE, SEAT HOOK	座墊鎖線	1	100			
31	98507-05010	SCREW, PAN HEAD	盤頭螺絲	1	3			
32	3UH-F7114-00	STOPPER, MAIN STAND	停止器	2	7			
33	5CA-F840F-00	BACK REST ASSY	靠背	1	530			
34	95707-06500	NUT, FLG	凸緣螺帽	2	3			
35	5CA-F4812-00-4B	HANDLE	把手	1	800			黑色 2 ,5CA7,5CA8
	5CA-F4812-10	HANDLE	把手	1				5CA4 曲面印刷
36	90119-08838	BOLT, WITH WASHER	六角套頭螺栓	3	5			
37	4DH-F6199-00	PLUG, BLIND	堵塞	2	10			

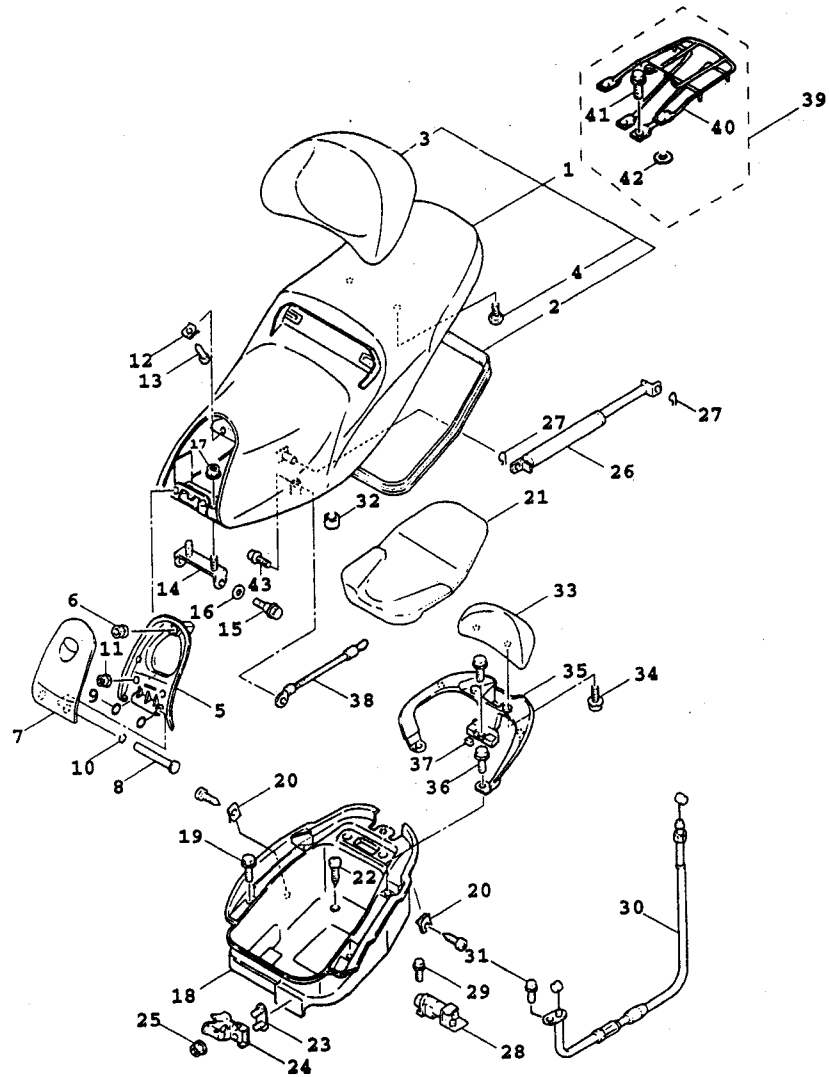

5CA1414-8201

FIG. 24 座墊

項次	部品番號	英文名稱	中文名稱	用量	建議價格	備註	代碼	工時
38	5CA-F1398-00	HANGER, HELMET	安全帽吊架	1	30			
39	5CA-W2484-00	CARRIER ASSY	後架總成	1	650			
40	5CA-F4842-00	.CARRIER, REAR	托架2	1	600	OPTION PARTS		
41	91317-06020	.BOLT, HEX. SOCKET	六角套頭螺栓	4	5	OPTION PARTS		
42	90201-06050	.WASHER, PLATE	平墊圈	4	3	OPTION PARTS		
43	90109-06001	BOLT	螺栓	1	5			

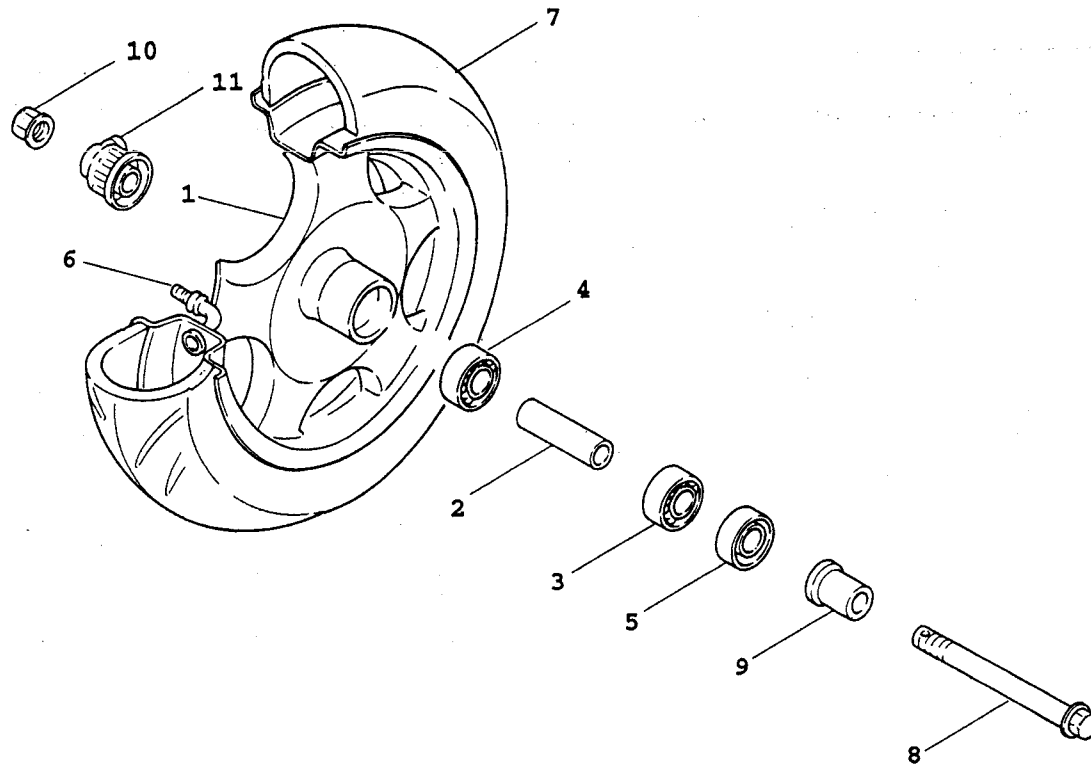

5CA1414-8210

FIG. 25 前輪

項次	部品番號	英文名稱	中文名稱	用量	建議價格	備註	代碼	工時
1	5CA-F5168-00-1V	CAST WHEEL, FRONT	前鑄輪	1	1,700	銀色		
2	90387-128V2	COLLAR	軸環	1	25			
3	93306-201Y2	BRG.	軸承	1	50			
4	93306-301Y3	BRG.	軸承	1	55			
5	93102-17853	SEAL, OIL	油封	1	7			
6	93900-00802	VALVE, RIM	氣門嘴	1	35			
7	94112-12800	TIRE	輪胎	1				
8	3UH-F2141-00	SHAFT, PIVOT	後臂軸	1	43			
9	90387-125J1	COLLAR	軸環	1	23			
10	95607-12200	NUT, SELF-LOCKING	U型螺帽	1	20			
11	5CA-F5190-00	GEAR UNIT ASSY	齒輪組件總成	1	300			

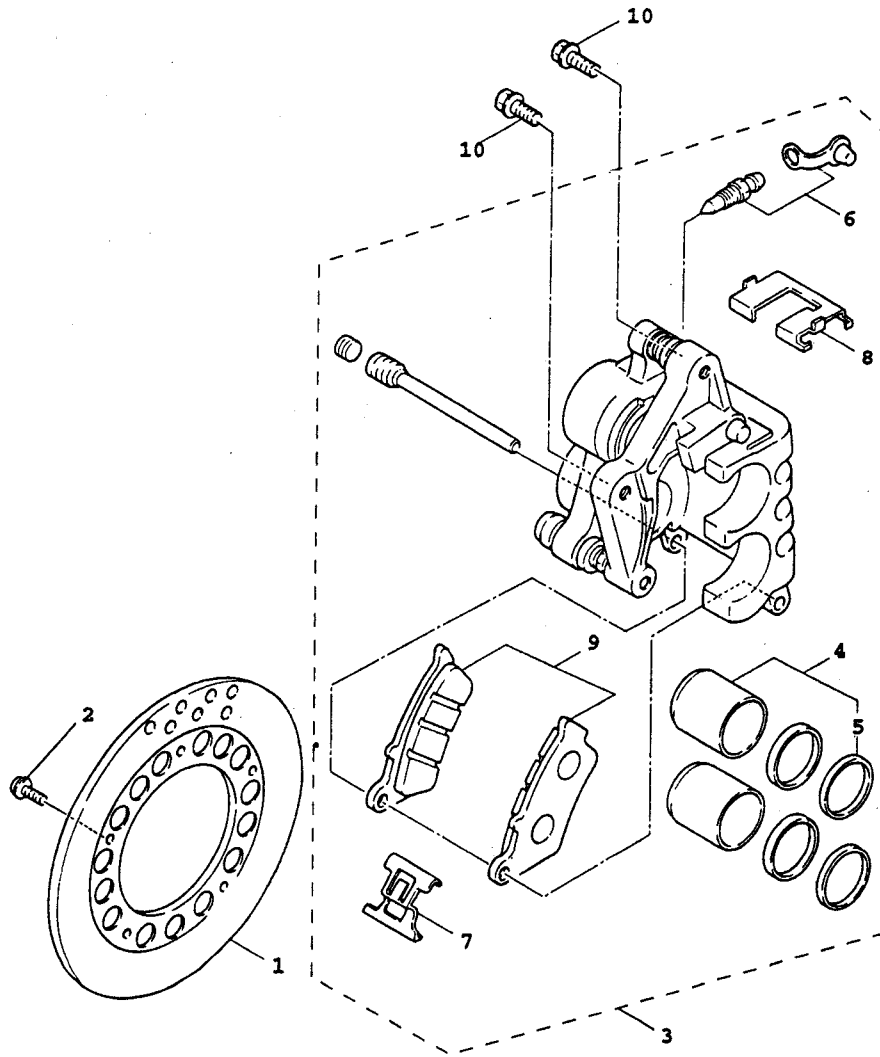

5CA1414-8220

FIG. 26 前剎車卡鉗

項次	部品番號	英文名稱	中文名稱	用量	建議價格	備註	代碼	工時
1	5CA-F582U-00	DISC, BRAKE (RIGHT)	剎車圓盤	1	1,000			
2	90149-08814	SCREW	螺絲	5	7			
3	5CA-F580U-00	CALIPER ASSY (RIGHT)	卡鉗總成	1	1,500			
4	5AG-W0057-00	.PISTON ASSY, CALIPER	卡鉗活塞	2	100			
5	5AG-W0047-00	..CALIPER SEAL KIT	卡鉗封圈組	2	55			
6	5AG-W0048-00	.BREED SCREW KIT	螺栓桿組	1	30			
7	5AG-F5919-00	.SUPPORT, PAD	緩衝器支座	1	20			
8	5AG-F5919-10	.SUPPORT, PAD	緩衝器支座	1	20			
9	5AG-W0045-00	.BRAKE PAD KIT	前剎車片組	1	400			
10	90105-10850	BOLT, WASHER BASED	墊圈座帽螺栓	2	8			

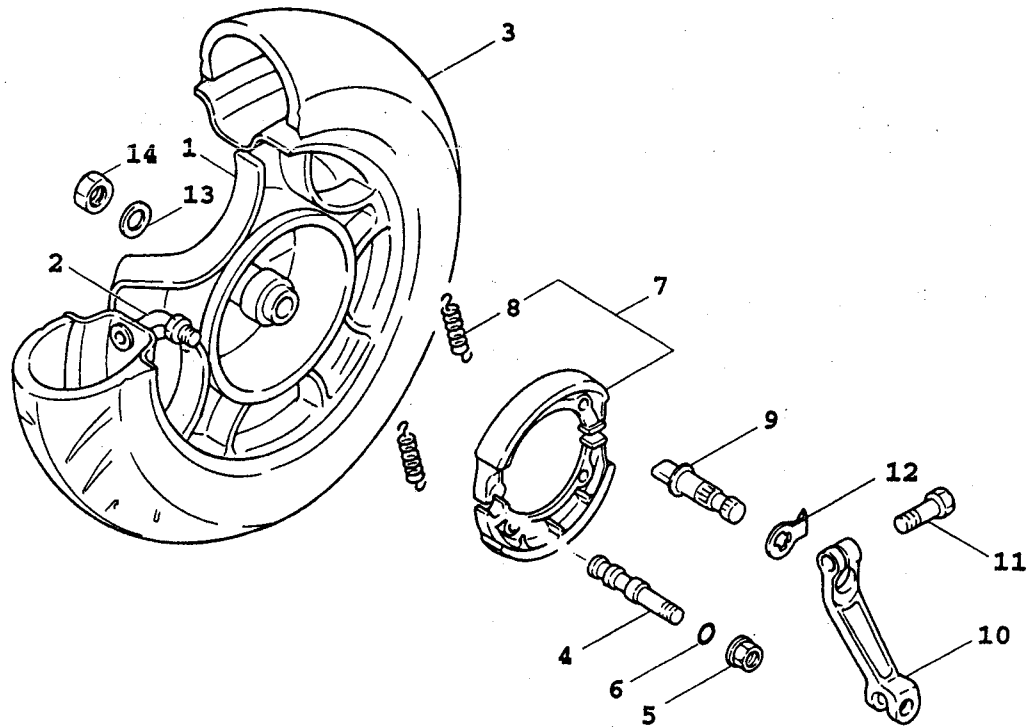

5CA1414-8230

FIG. 27 後輪

項次	部品番號	英文名稱	中文名稱	用量	建議價格	備註	代碼	工時
1	5CA-F5338-00-1V	CAST WHEEL, REAR	後鑄輪	1	1,900	銀色		
2	93900-00802	VALVE, RIM	氣門嘴	1	35			
3	94113-12800	TIRE	輪胎	1				
4	3UH-F5326-00	PIN, PIVOT	叉銷	1	18			
5	95707-10500	NUT, FLG	凸緣螺帽	1	5			
6	93210-07890	O-RING	護油圈	1	5			
7	3UH-X2533-00	BRAKE SHOE SET	剎車塊組	1	240			
8	90506-16447	.SPRING, TENSION	拉力彈簧	2	10			
9	3UH-F5351-00	CAMSHAFT	凸輪軸	1	38			
10	5CA-F5355-00	LEVER, CAMSHAFT	凸輪軸臂桿	1	120			
11	90101-06878	BOLT	六角螺栓	1	3			
12	4VP-F533A-00	PLATE, INDICATOR	指示板	1	5			
13	90201-220J8	WASHER, PLATE	平墊圈	1	10			
14	90185-14124	NUT, SELF-LOCKING	自鎖螺帽	1	45			

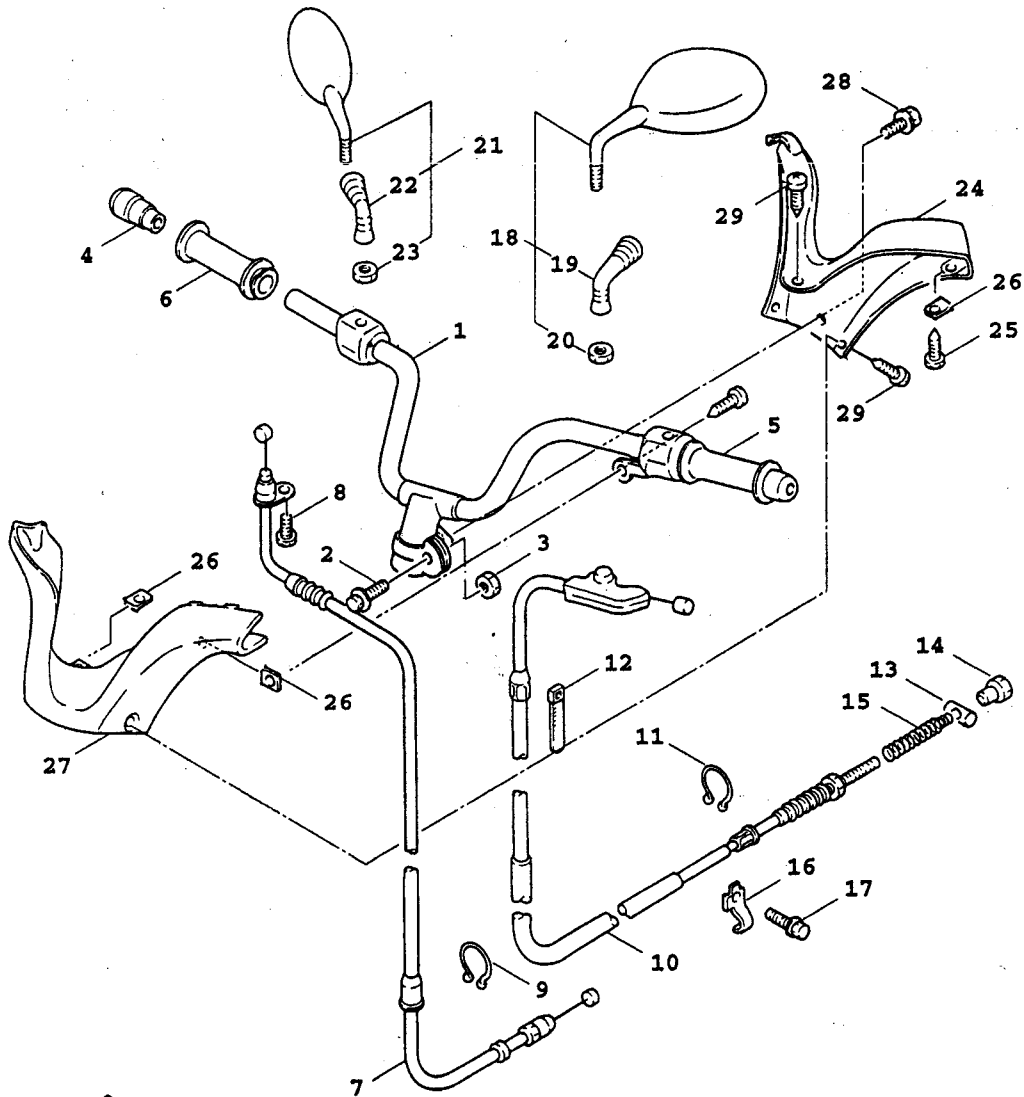

5CA1414-8240

FIG. 28 轉向把手，鋼索

項次	部品番號	英文名稱	中文名稱	用量	建議價格	備註	代碼	工時
1	5CA-F6110-00	HANDLE COMP.	把手整體	1	450			
2	90105-10036	BOLT, WASHER BASED	墊圈座帽螺栓	1	7			
3	95607-10200	NUT, SELF-LOCKING	U型螺帽	1	5			
4	5CA-F6246-00	END, GRIP	握把尾端	2	40			
5	5CA-F6241-00	GRIP (LEFT)	左握把	1	25			
6	5CA-F6240-00	GRIP ASSY	右握把總成	1	40			
7	5CA-F6311-00	CABLE, THROTTLE 1	節流鋼索1	1	120			
8	98507-05010	SCREW, PAN HEAD	盤頭螺絲	1	3			
9	90464-23811	CLAMP	夾	1	7			
10	5CA-F6351-11	CABLE, BRAKE	剎車鋼索2	1	210			
11	90464-23811	CLAMP	夾	1	7			
12	90465-13275	CLAMP	夾	2	14			
13	90249-12008	PIN	銷	1	5			
14	90179-06411	NUT	螺帽	1	7			
15	90501-16869	SPRING, COMPRESSION	壓力彈簧	1	10			
16	5CA-F627E-00	CLAMP, WIRE	夾	1	15			
17	95027-06016	BOLT, FLG	凸緣螺栓	1	3			
18	5CA-F6280-00	REAR VIEW MIRROR ASSY	左後視鏡總成	1	110			
19	5CA-F629T-00	.BOOT 1	保護罩	1	20			

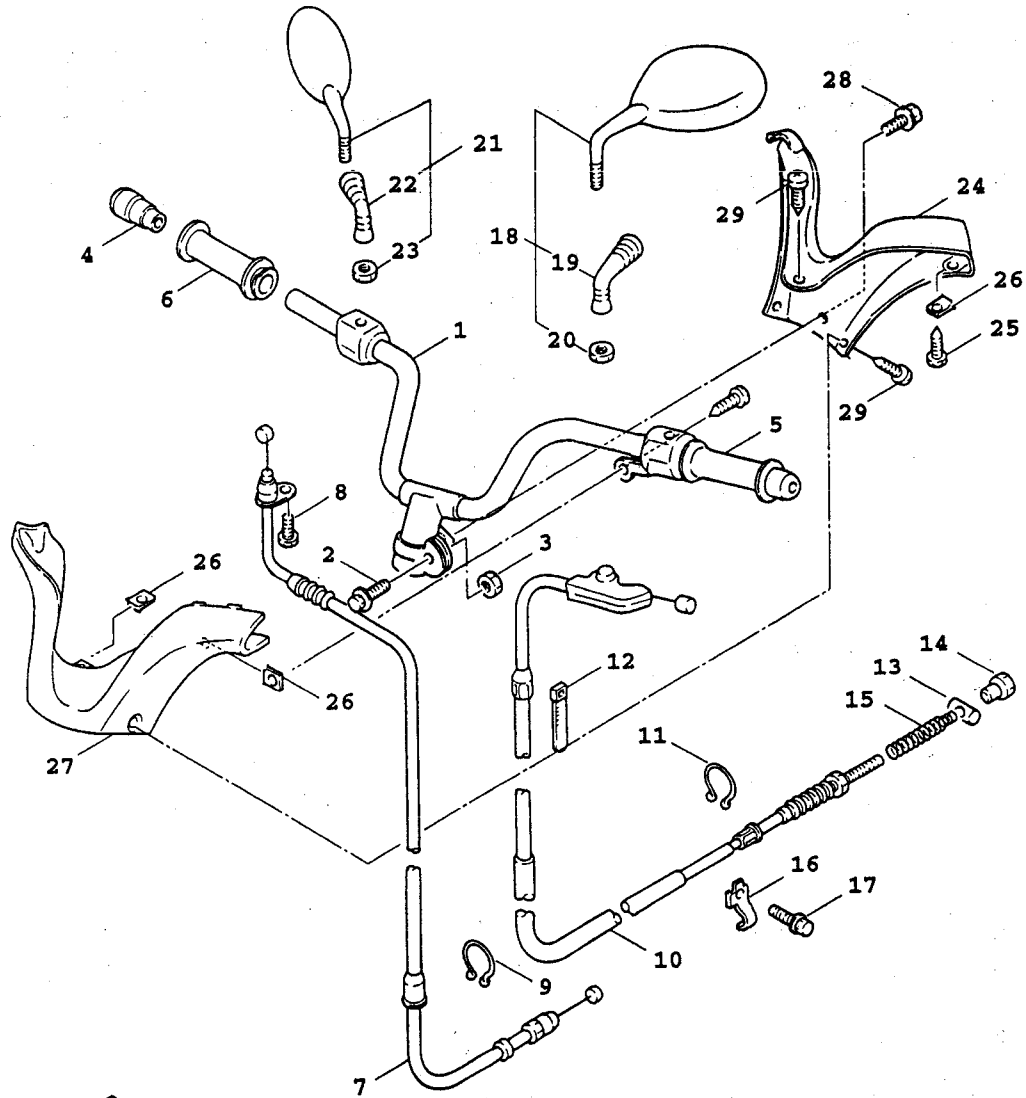

5CA1414-8240

FIG. 28 轉向把手，鋼索

項次	部品番號	英文名稱	中文名稱	用量	建議價格	備註	代碼	工時
20	5CA-F6294-00	.NUT 1	螺帽	1	10			
21	5CA-F6290-00	REAR VIEW MIRROR ASSY	右後視鏡總成	1	110			
22	5CA-F629T-00	.BOOT 1	保護罩	1	20			
23	5CA-F6295-00	.NUT, 2	螺帽	1	10			
24	5CA-F6143-00	COVER, HANDLEBAR UPPER 1	把手蓋 1	1	100			
25	97707-50016	SCREW, TAPPING	攻螺絲	2	3			
26	90183-05807	NUT, SPRING	彈簧螺帽	5	5			
27	5CA-F6145-00	COVER, HANDLEBAR UPPER 2	把手蓋 2	1	80			
28	90159-05831	SCREW, WITH WASHER	螺絲附墊圈	1	5			
29	97707-50016	SCREW, TAPPING	攻螺絲	5	3			

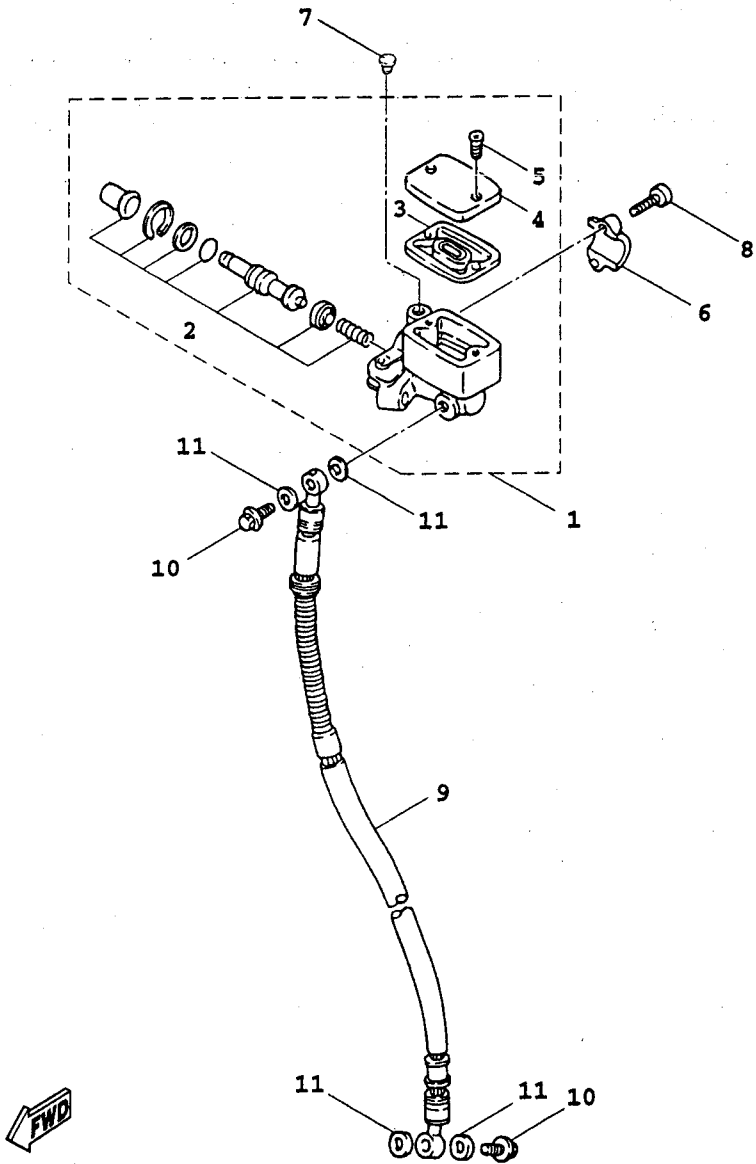

5CA1414-8250

FIG. 29 前主缸

項次	部品番號	英文名稱	中文名稱	用量	建議價格	備註	代碼	工時
1	5CA-F5870-00	MASTER CYLINDER SUB ASSY	主缸總成	1	700			
2	5CA-W0041-00	.CYLINDER KIT, MASTER	主缸推進器	1	190			
3	3GF-F5854-00	.DIAPHRAGM, RESERVOIR	油槽隔片	1	23			
4	3GF-F5852-00	.CAP, RESERVOIR	油槽蓋	1	39			
5	98707-04012	.SCREW, FLAT HEAD	平頭螺絲	2	7			
6	3GF-F5867-00	BRACKET, MASTER CYLINDER	主缸支架	1	22			
7	90338-09012	PLUG	塞	1	5			
8	91317-06025	BOLT, HEX. SOCKET	六角套頭螺栓	2	5			
9	5CA-F5872-00	HOSE, BRAKE 1	剎車管 1	1	600			
10	90401-10805	BOLT, UNION	接合螺栓	2	11			
11	90201-10118	WASHER, PLATE	平墊圈	4	3			

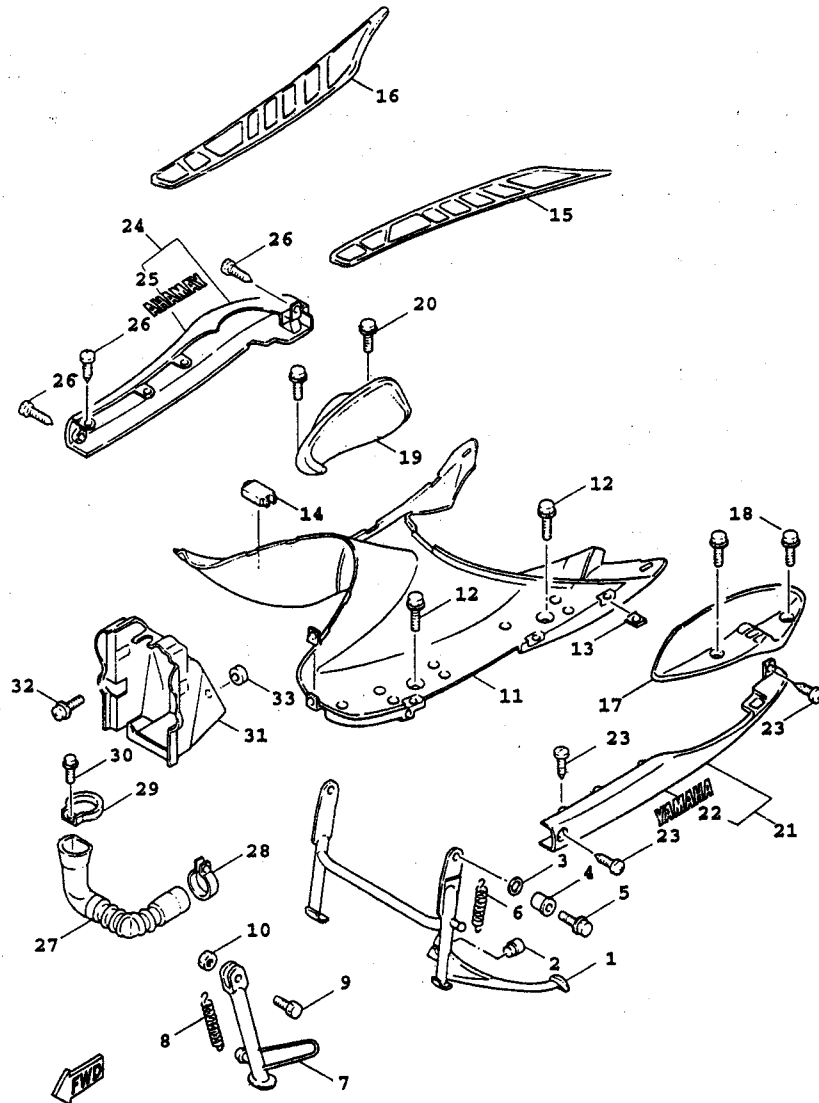

5CA1414-8261

FIG. 30 支架、置腳踏 YP125D(5CA4)

項次	部品番號	英文名稱	中文名稱	用量	建議價格	備註	代碼	工時
1	5CA-F7111-00	STAND, MAIN	主支架	1	320	5CA4		
2	3UH-F7114-00	STOPPER, MAIN STAND	停止器	1	7			
3	90202-15804	WASHER, PLATE	平墊圈	2	5			
4	90387-10800	COLLAR	軸環	2	20			
5	95827-10035	BOLT, FLG	凸緣螺栓	2	5			
6	90506-32834	SPRING, TENSION	拉力彈簧	1	15			
7	5CA-F7311-00	STAND, SIDE	側支架	1	100			
8	90506-20841	SPRING, TENSION	拉力彈簧	1	8			
9	90109-08881	BOLT	螺栓	1	10			
10	90185-08818	NUT, SELF-LOCKING	自鎖螺帽	1	7			
11	5CA-F7481-00	BOARD, FOOTREST	置腳踏板	1	300			
12	90119-06821	BOLT, WITH WASHER	六角套頭螺栓	4	5			
13	90183-05807	NUT, SPRING	彈簧螺帽	14	5			
14	5CA-F7453-00	COVER 1	蓋 1	1	15			
15	5CA-F7483-00	MAT 1	置腳踏板墊	1	80			
16	5CA-F7484-00	MAT 2	置腳踏板墊	1	80			
17	5CA-F7486-00	COVER 1	蓋 1	1	60			
18	90119-06821	BOLT, WITH WASHER	六角套頭螺栓	2	5			
19	5CA-F7487-00	COVER 2	蓋 2	1	60			

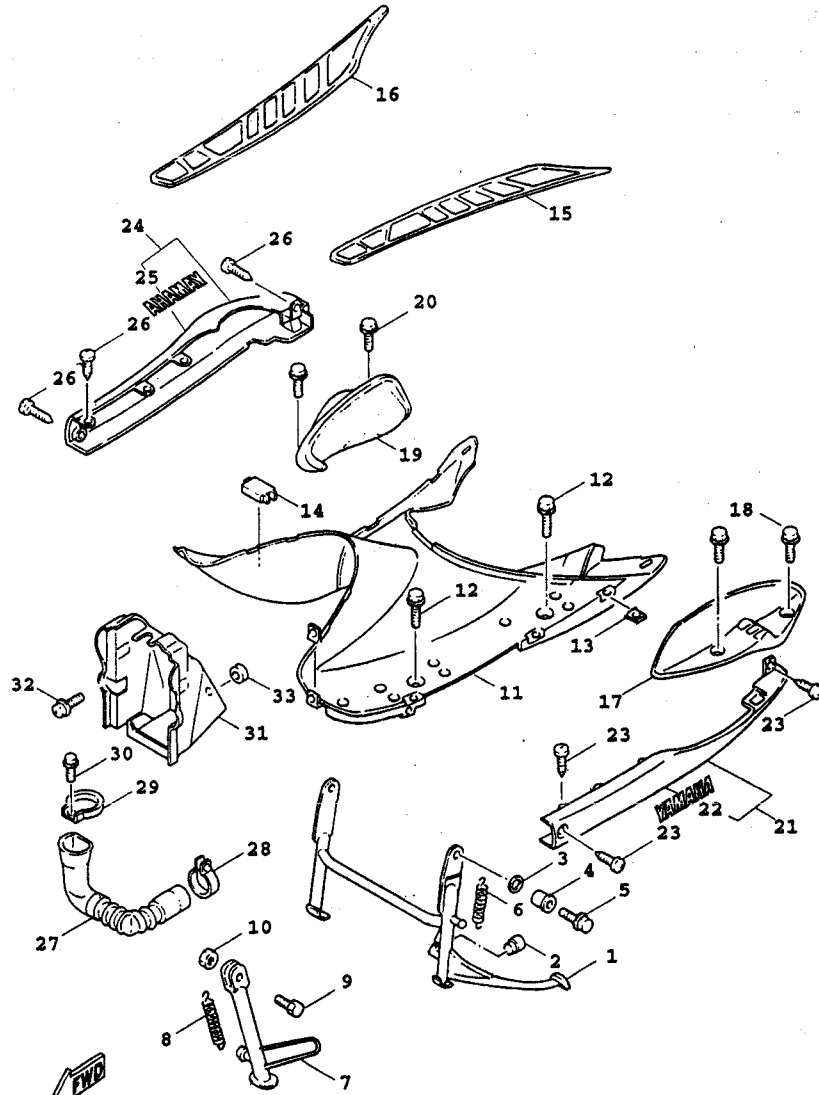

5CA1414-8261

FIG. 30 支架、置腳踏 YP125D(5CA4)

項次	部品番號	英文名稱	中文名稱	用量	建議價格	備註	代碼	工時
20	90119-06821	BOLT, WITH WASHER	六角套頭螺栓	2	5			
21	5CA-X7496-10-4B	MOLE SIDE 1	護片 1	1	300	黑色 2		
22	5CA-F748A-10	.GRAPHIC 1	圖案	1				
23	97707-50016	SCREW, TAPPING	攻螺絲	6	3			
24	5CA-X7497-10-4B	MOLE SIDE 2	護片 2	1	300	黑色 2		
25	5CA-F748A-10	.GRAPHIC 1	圖案	1				
26	97707-50016	SCREW, TAPPING	攻螺絲	6	3			
27	5CA-F1557-00	DUCT AIR	空氣導管	1	190			
28	5CA-F1823-00	CLAMP, HOSE	夾	1	25			
29	5CA-F1161-00	HOLDER, CABLE	鋼索導件	1	30			
30	95807-06012	BOLT, FLG	凸緣螺栓	1	3			
31	5CA-F174F-00	GUARD, RADIATOR	防護板	1	90			
32	90159-06150	SCREW, WITH WASHER	螺絲附墊圈	2	5			
33	90480-23885	GROMMET	索環	1	10			

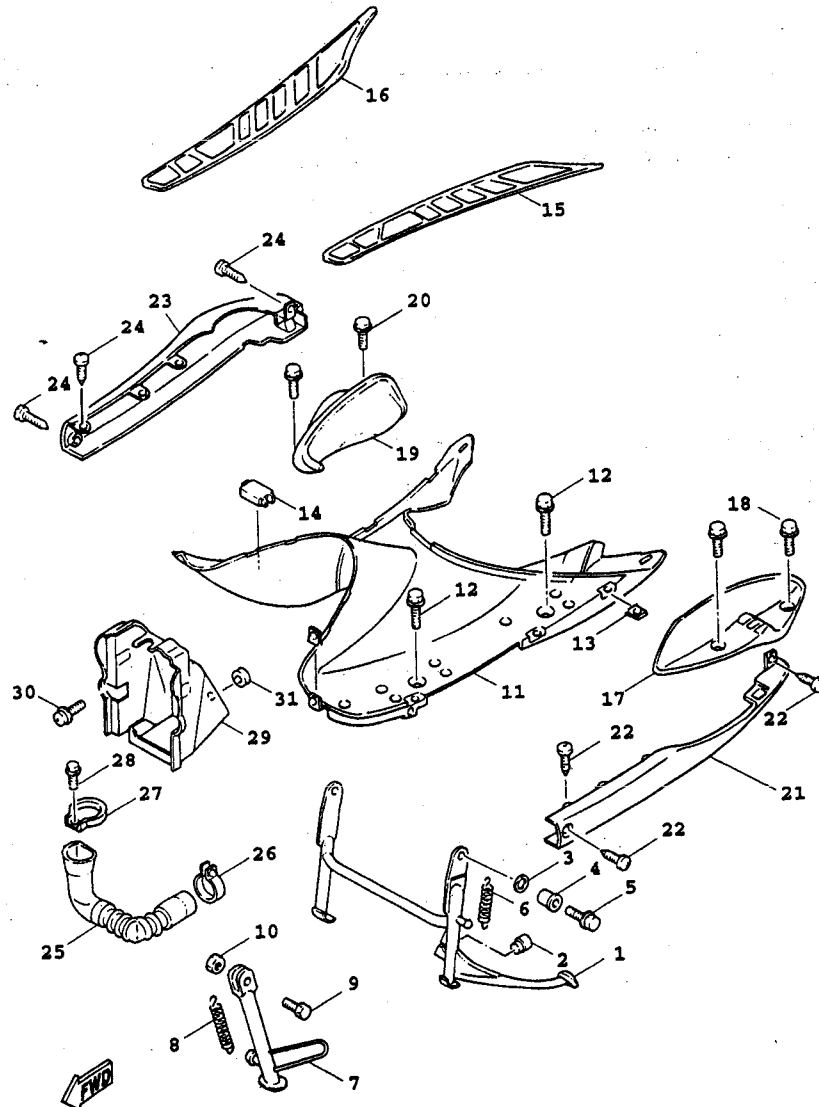

5CA7414-0310

FIG. 31 支架，置腳踏 YP125C(5CA7)

項次	部品番號	英文名稱	中文名稱	用量	建議價格	備註	代碼	工時
1	5CA-F7111-00	STAND, MAIN	主支架	1	320		5CA7	
2	3UH-F7114-00	STOPPER, MAIN STAND	停止器	1	7			
3	90202-15804	WASHER, PLATE	平墊圈	2	5			
4	90387-10800	COLLAR	軸環	2	20			
5	95827-10035	BOLT.FLG	凸緣螺栓	2	5			
6	90506-32834	SPRING, TENSION	拉力彈簧	1	15			
7	5CA-F7311-00	STAND, SIDE	側支架	1	100			
8	90506-20841	SPRING, TENSION	拉力彈簧	1	8			
9	90109-08881	BOLT	螺栓	1	10			
10	90185-08818	NUT, SELF-LOCKING	自鎖螺帽	1	7			
11	5CA-F7481-00	BOARD, FOOTREST	置腳踏板	1	300			
12	90119-06821	BOLT, WITH WASHER	六角套頭螺栓	4	5			
13	90183-05807	NUT, SPRING	彈簧螺帽	14	5			
14	5CA-F7453-00	COVER 1	蓋 1	1	15			
15	5CA-F7483-00	MAT 1	置腳踏板墊	1	80			
16	5CA-F7484-00	MAT 2	置腳踏板墊	1	80			
17	5CA-F7486-00	COVER 1	蓋 1	1	60			
18	90119-06821	BOLT, WITH WASHER	六角套頭螺栓	2	5			
19	5CA-F7487-00	COVER 2	蓋 2	1	60			

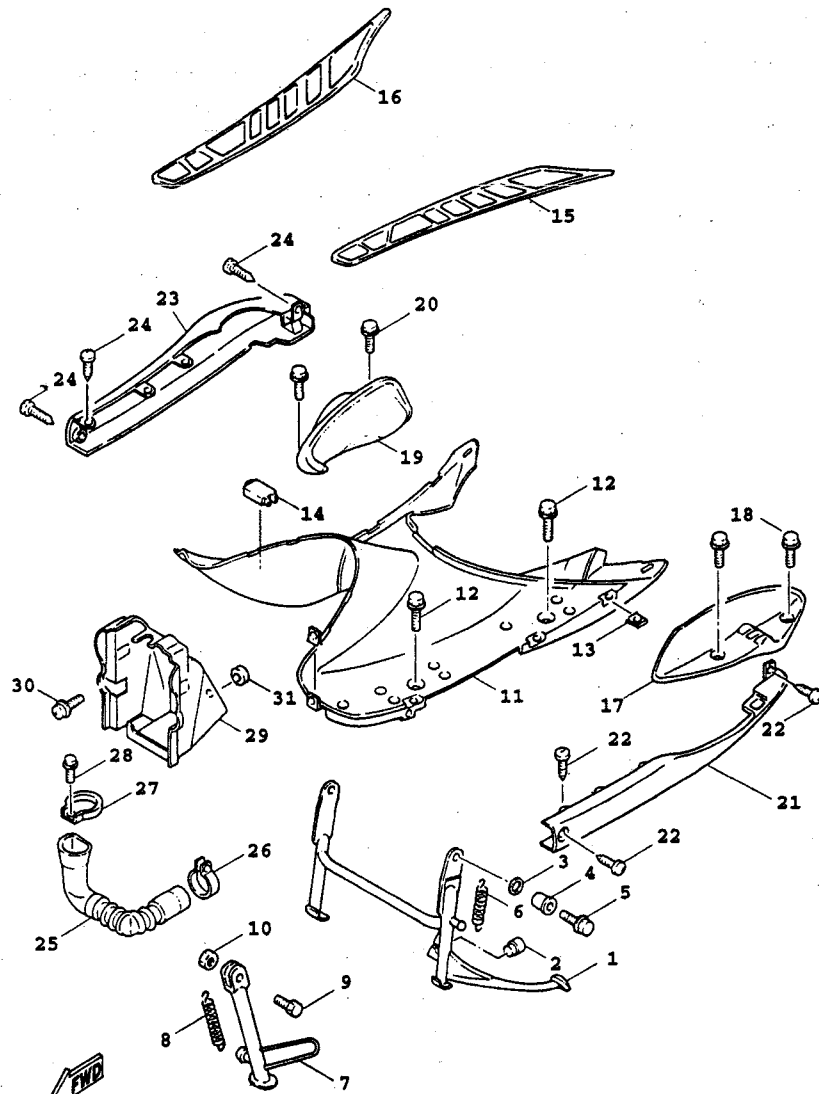

5CA7414-0310

FIG. 31 支架，置腳踏 YP125C(5CA7)

項次	部品番號	英文名稱	中文名稱	用量	建議價格	備註	代碼	工時
20	90119-06821	BOLT, WITH WASHER	六角套頭螺栓	2	5			
21	5CA-F7496-00-P7	MOLE 1	護片 1	1	260	用於黑車		
	5CA-F7496-00-1V	MOLE 1	護片 1	1	260	用於銀車		
	5CA-F7496-00-P4	MOLE 1	護片 1	1	260	用於深綠車		
22	97707-50016	SCREW, TAPPING	攻螺絲	6	3			
23	5CA-F7497-00-P7	MOLE 2	護片 2	1	260	用於黑車		
	5CA-F7497-00-1V	MOLE 2	護片 2	1	260	用於銀車		
	5CA-F7497-00-P4	MOLE 2	護片 2	1	260	於深綠車		
24	97707-50016	SCREW, TAPPING	攻螺絲	6	3			
25	5CA-F1557-00	DUCT AIR	空氣導管	1	190			
26	5CA-F1823-00	CLAMP, HOSE	夾	1	25			
27	5CA-F1161-00	HOLDER, CABLE	鋼索導件	1	30			
28	95807-06012	BOLT, FLG	凸緣螺栓	1	3			
29	5CA-F174F-00	GUARD, RADIATOR	防護板	1	90			
30	90159-06150	SCREW, WITH WASHER	螺絲附墊圈	2	5			
31	90480-23885	GROMMET	索環	1	10			

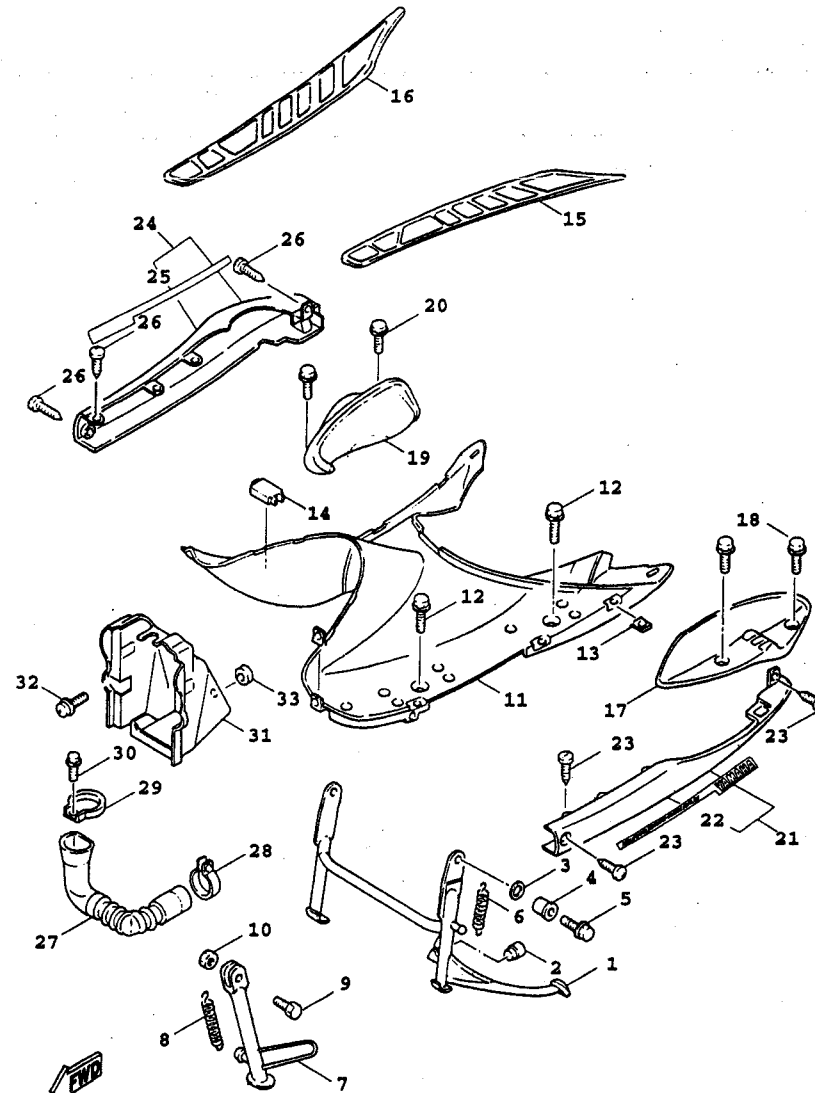

5CA8414-0320

FIG. 32 支架，置腳踏 YP125A(5CA8)

項次	部品番號	英文名稱	中文名稱	用量	建議價格	備註	代碼	工時
1	5CA-F7111-00	STAND, MAIN	主支架	1	320	5CA8		
2	3UH-F7114-00	STOPPER, MAIN STAND	停止器	1	7			
3	90202-15804	WASHER, PLATE	平墊圈	2	5			
4	90387-10800	COLLAR	軸環	2	20			
5	95827-10035	BOLT.FLG	凸緣螺栓	2	5			
6	90506-32834	SPRING, TENSION	拉力彈簧	1	15			
7	5CA-F7311-00	STAND, SIDE	側支架	1	100			
8	90506-20841	SPRING, TENSION	拉力彈簧	1	8			
9	90109-08881	BOLT	螺栓	1	10			
10	90185-08818	NUT, SELF-LOCKING	自鎖螺帽	1	7			
11	5CA-F7481-00	BOARD, FOOTREST	置腳踏板	1	300			
12	90119-06821	BOLT, WITH WASHER	六角套頭螺栓	4	5			
13	90183-05807	NUT, SPRING	彈簧螺帽	14	5			
14	5CA-F7453-00	COVER 1	蓋 1	1	15			
15	5CA-F7483-00	MAT 1	置腳踏板墊	1	80			
16	5CA-F7484-00	MAT 2	置腳踏板墊	1	80			
17	5CA-F7486-00	COVER 1	蓋 1	1	60			
18	90119-06821	BOLT, WITH WASHER	六角套頭螺栓	2	5			
19	5CA-F7487-00	COVER 2	蓋 2	1	60			

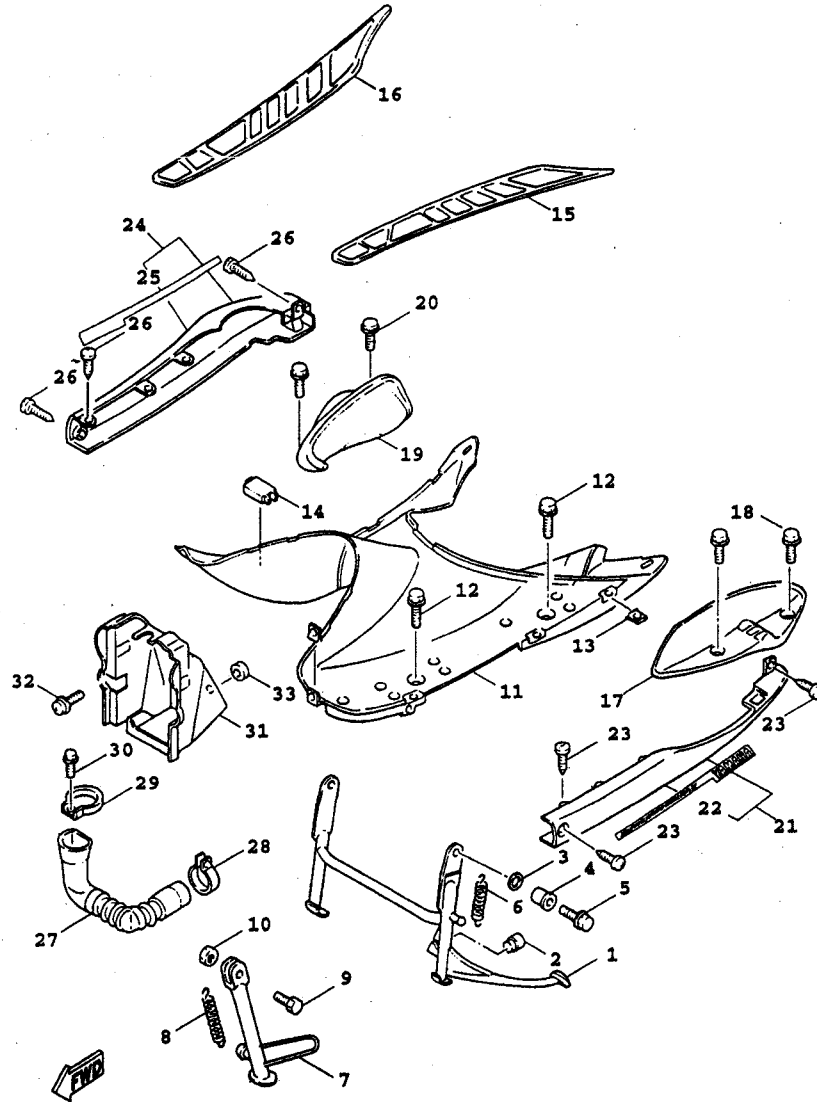

5CA8414-0320

FIG. 32 支架，置腳踏 YP125A(5CA8)

項次	部品番號	英文名稱	中文名	用量	建議價格	備註	代碼	工時
20	90119-06821	BOLT, WITH WASHER	六角套頭螺栓	2	5			
21	5CA-X7496-20-4B	MOLE SIDE 1	護片 1	1	300	用於黑車		
	5CA-X7496-20-1V	MOLE SIDE 1	護片 1	1	300	用於銀車		
22	5CA-F7402-00	.GRAPHIC SET	左圖案組	1		用於黑車		
	5CA-F7402-10	.GRAPHIC SET	左圖案組	1		用於銀車		
23	97707-50016	SCREW, TAPPING	攻螺絲	6	3			
24	5CA-X7497-20-4B	MOLE SIDE 2	護片 2	1	300	用於黑車		
	5CA-X7497-20-1V	MOLE SIDE 2	護片 2	1	300	用於銀車		
25	5CA-F7403-00	.GRAPHIC SET	右圖案組	1		用於黑車		
	5CA-F7403-10	.GRAPHIC SET	右圖案組	1		用於銀車		
26	97707-50016	SCREW, TAPPING	攻螺絲	6	3			
27	5CA-F1557-00	DUCT AIR	空氣導管	1	190			
28	5CA-F1823-00	CLAMP, HOSE	夾	1	25			
29	5CA-F1161-00	HOLDER, CABLE	鋼索導件	1	30			
30	95807-06012	BOLT, FLG	凸緣螺栓	1	3			
31	5CA-F174F-00	GUARD, RADIATOR	防護板	1	90			
32	90159-06150	SCREW, WITH WASHER	螺絲附墊圈	2	5			
33	90480-23885	GROMMET	索環	1	10			

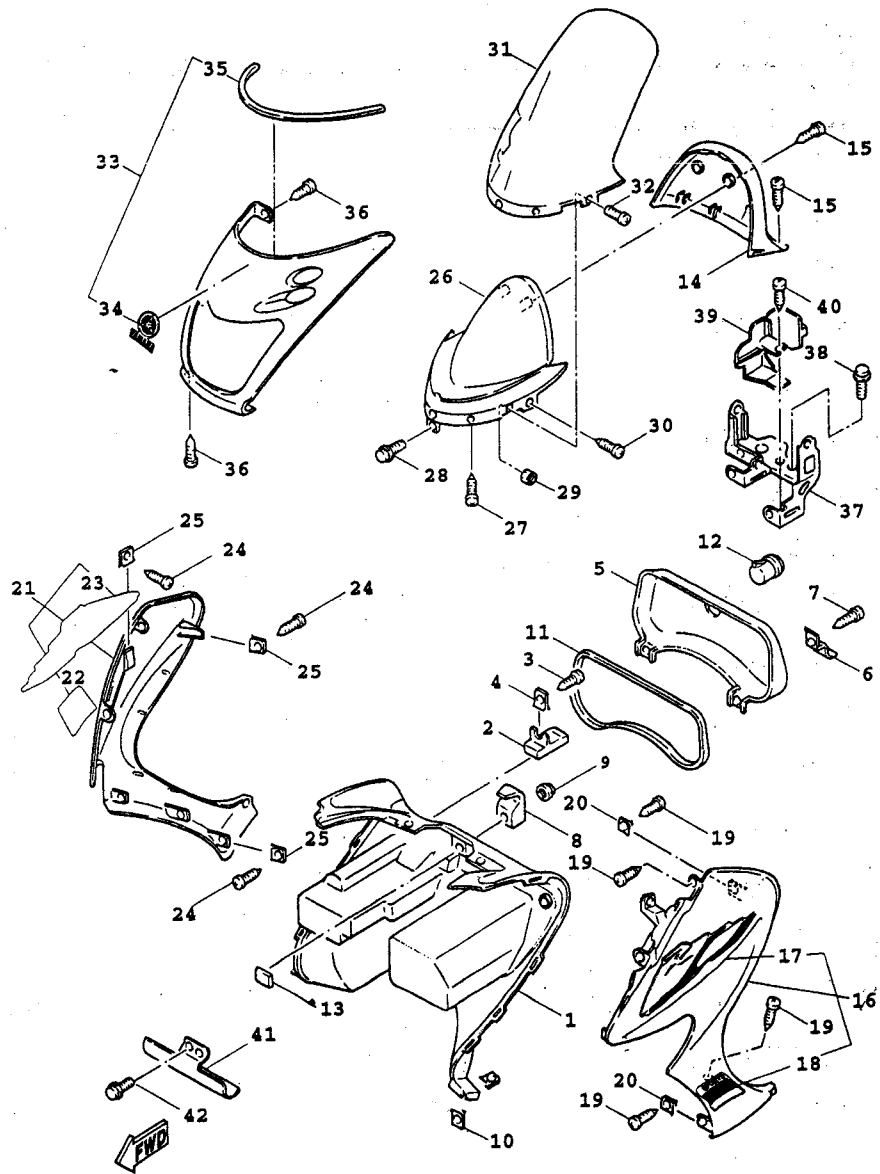

5CA4414-0330

FIG. 33 腳防護板 YP125D(5CA4)

項次	部品番號	英文名稱	中文名稱	用量	建議價格	備註	代碼	工時
1	5CA-F8311-00	LEG SHIELD 1	腳防護板 1	1	270		5CA4	
2	5CA-F8365-00	COVER	蓋	1	15			
3	97707-50016	SCREW, TAPPING	攻螺絲	1	3			
4	90183-05807	NUT, SPRING	彈簧螺帽	1	5			
5	5CA-F8313-00	LID	行李箱蓋	1	70			
6	1NT-F1796-00	HINGE	絞鏈	2	5			
7	97707-40512	SCREW, TAPPING	攻螺絲	2	3			
8	5CA-F8257-00	HOOK 1	鉤 1	1	10			
9	90176-06805	NUT, CROWN	有蓋螺帽	1	5			
10	90183-05807	NUT, SPRING	彈簧螺帽	4	5			
11	4TE-F8371-00	DAMPER	防震墊	1	5			
12	23Y-F1708-V0	SIDE COVER LOCK ASSY	箱蓋鎖	1	60			
13	1NT-F834V-00	PROTECTOR 1	護罩 1	1	3			
14	5CA-F836L-00	PANEL, INNER 2	內嵌板 2	1	80			
15	97707-50016	SCREW, TAPPING	攻螺絲	4	3			
16	5CA-X283U-00-2X	PANEL	前蓋	1	700			用於藍車
	5CA-X283U-00-3X	PANEL	前蓋	1	700			用於銀車
17	5CA-F8391-00	.GRAPHIC 1	圖案	1				用於藍車
	5CA-F8391-10	.GRAPHIC 1	圖案	1				用於銀車

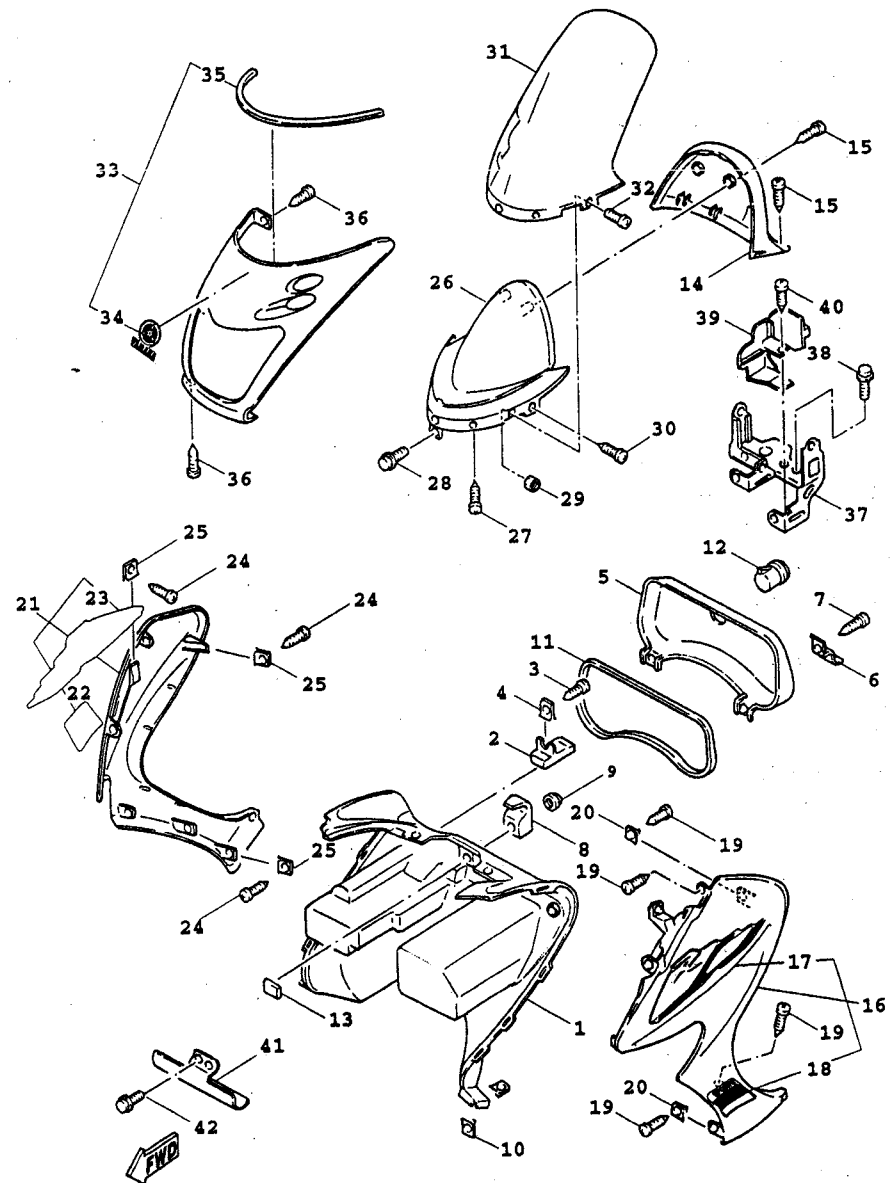

5CA4414-0330

FIG. 33 腳防護板 YP125D(5CA4)

項次	部品番號	英文名稱	中文名稱	用量	建議價格	備註	代碼	工時
18	5CA-F8393-00	.GRAPHIC 3	圖案	1		用於藍車		
	5CA-F8393-10	.GRAPHIC 3	圖案	1		用於銀車		
19	97707-50016	SCREW, TAPPING	攻螺絲	7	3			
20	90183-05807	NUT, SPRING	彈簧螺帽	7	5			
21	5CA-X283V-00-2X	PANEL	前蓋	1	700	用於藍車		
	5CA-X283V-00-3X	PANEL	前蓋	1	700	用於銀車		
22	5CA-F8392-00	.GRAPHIC 2	圖案	1		用於藍車		
	5CA-F8392-10	.GRAPHIC 2	圖案	1		用於銀車		
23	5CA-F8394-00	.GRAPHIC 4	圖案	1		用於藍車		
	5CA-F8394-10	.GRAPHIC 4	圖案	1		用於銀車		
24	97707-50016	SCREW, TAPPING	攻螺絲	7	3			
25	90183-05807	NUT, SPRING	彈簧螺帽	7	5			
26	5CA-F836K-00	PANEL, INNER 1	整流罩結合板	1	60			
27	97707-50016	SCREW, TAPPING	攻螺絲	2	3			
28	90119-06821	BOLT, WITH WASHER	六角套頭螺栓	1	5			
29	90179-05849	NUT	螺帽	5	7			
30	90159-05083	SCREW, WITH WASHER	螺絲附墊圈	2	3			
31	5CA-F837U-10	SCREEN	透明罩	1	1,300			
32	90150-05024	SCREW, ROUND HEAD	螺絲	5	15			

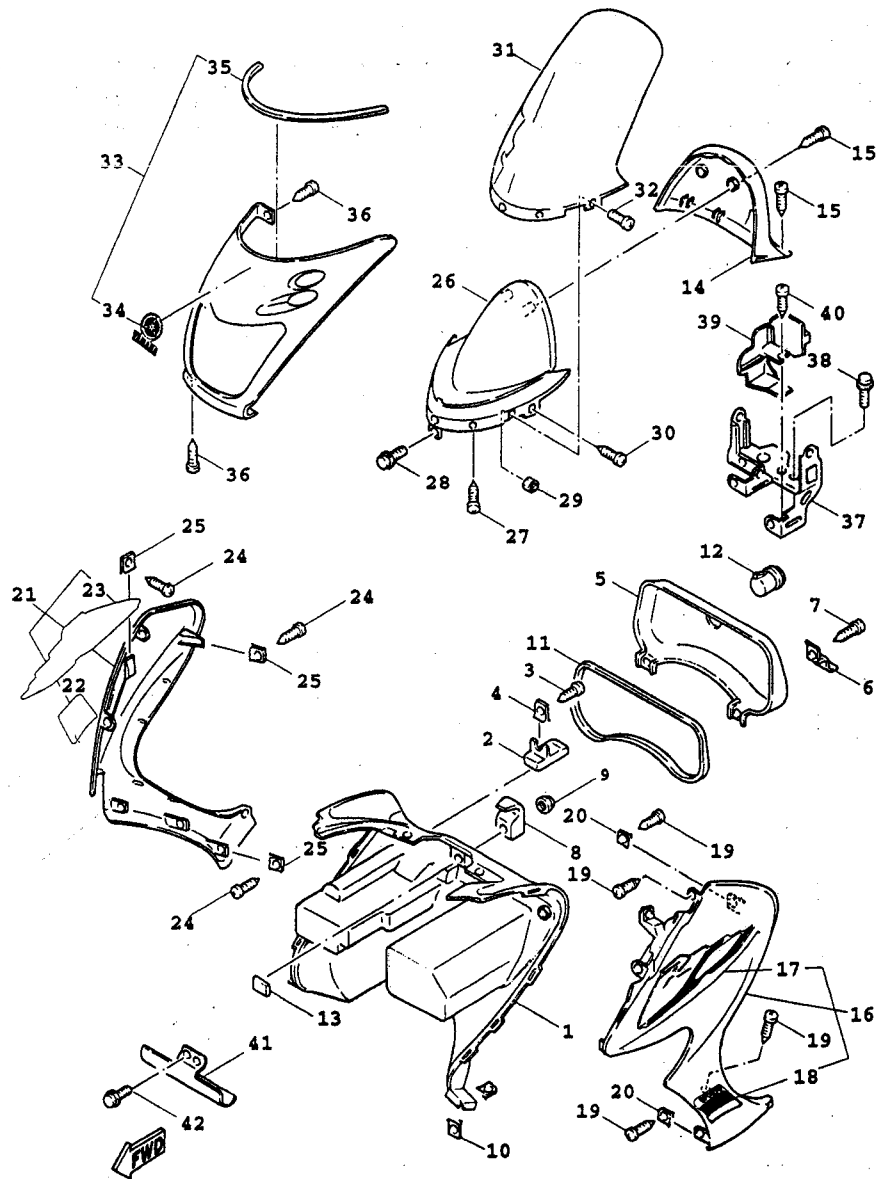

5CA4414-0330

FIG. 33 腳防護板 YP125D(5CA4)

項次	部品番號	英文名稱	中文名稱	用量	建議價格	備註	代碼	工時
33	5CA-X2834-10-4B	MOLE 1	護板	1	1,350			
34	5CA-F8328-00	.EMBLEM	標誌	1				
35	5CA-F8347-00	.MOLE 3	護片 3	1	15			
36	97707-50016	SCREW, TAPPING	攻螺絲	4	3			
37	5CA-F8356-10	STAY 1	固定座 1	1	250			
38	95807-06012	BOLT, FLG	凸緣螺栓	2	3			
39	5CA-F834V-00	PROTECTOR 1	護罩 1	1	20			
40	90159-06813	SCREW, WITH WASHER	螺絲附墊圈	1	3			
41	5CA-F834W-00	PROTECTOR 2	護罩 2	1	70			
42	95807-06014	BOLT, FLG	凸緣螺栓	2	3			

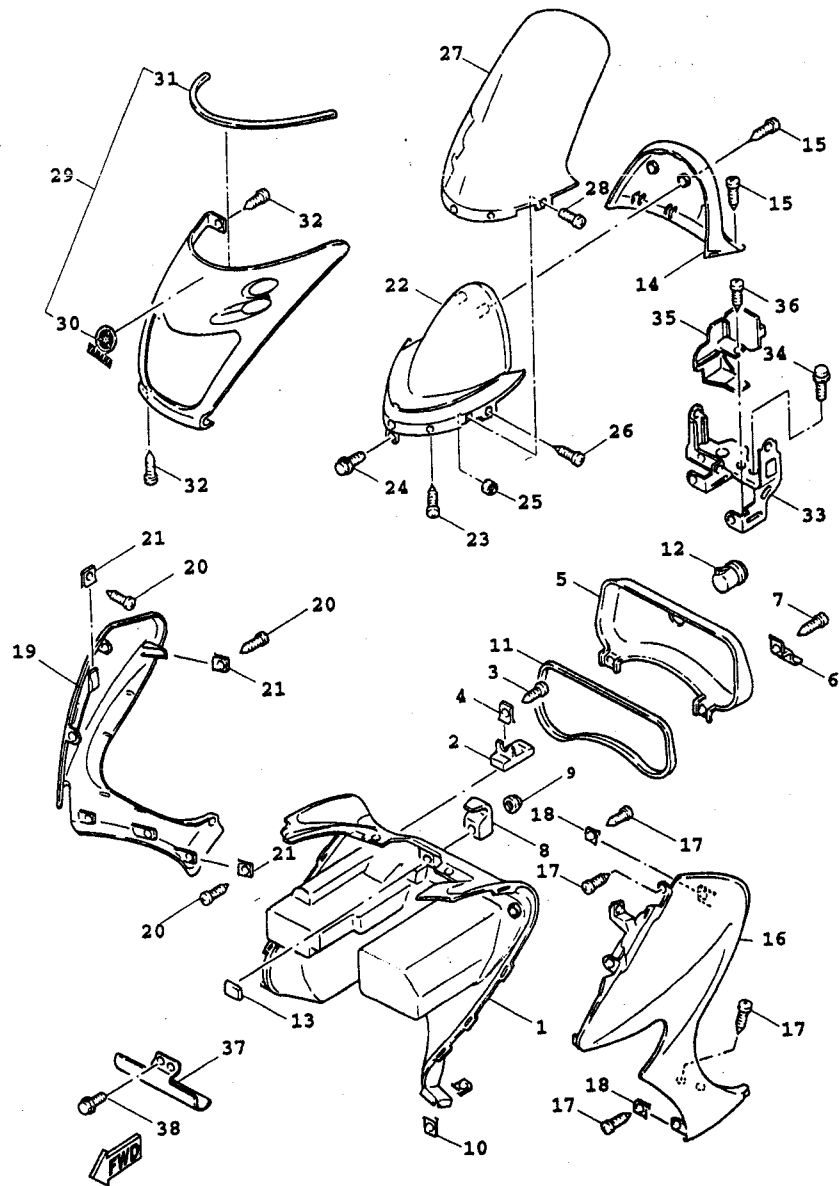

5CA7414-0340

FIG. 34 腳防護板 YP125C(5CA7)

項次	部品番號	英文名稱	中文名稱	用量	建議價格	備註	代碼	工時
1	5CA-F8311-00	LEG SHIELD 1	腳防護板 1	1	270		5CA7	
2	5CA-F8365-00	COVER	蓋	1	15			
3	97707-50016	SCREW, TAPPING	攻螺絲	1	3			
4	90183-05807	NUT, SPRING	彈簧螺帽	1	5			
5	5CA-F8313-00	LID	行李箱蓋	1	70			
6	1NT-F1796-00	HINGE	絞鏈	2	5			
7	97707-40512	SCREW, TAPPING	攻螺絲	2	3			
8	5CA-F8257-00	HOOK 1	鉤 1	1	10			
9	90176-06805	NUT, CROWN	有蓋螺帽	1	5			
10	90183-05807	NUT, SPRING	彈簧螺帽	4	5			
11	4TE-F8371-00	DAMPER	防震墊	1	5			
12	23Y-F1708-V0	SIDE COVER LOCK ASSY	箱蓋鎖	1	60			
13	1NT-F834V-00	PROTECTOR 1	護罩 1	1	3			
14	5CA-F836L-00	PANEL, INNER 2	內嵌板 2	1	80			
15	97707-50016	SCREW, TAPPING	攻螺絲	4	3			
16	5CA-F835U-00-P6	PANEL 1	前蓋	1	650			用於黑車
	5CA-F835U-00-1V	PANEL 1	前蓋	1	650			用於銀車
	5CA-F835U-00-P4	PANEL 1	前蓋	1	650			用於深綠車
17	97707-50016	SCREW, TAPPING	攻螺絲	7	3			

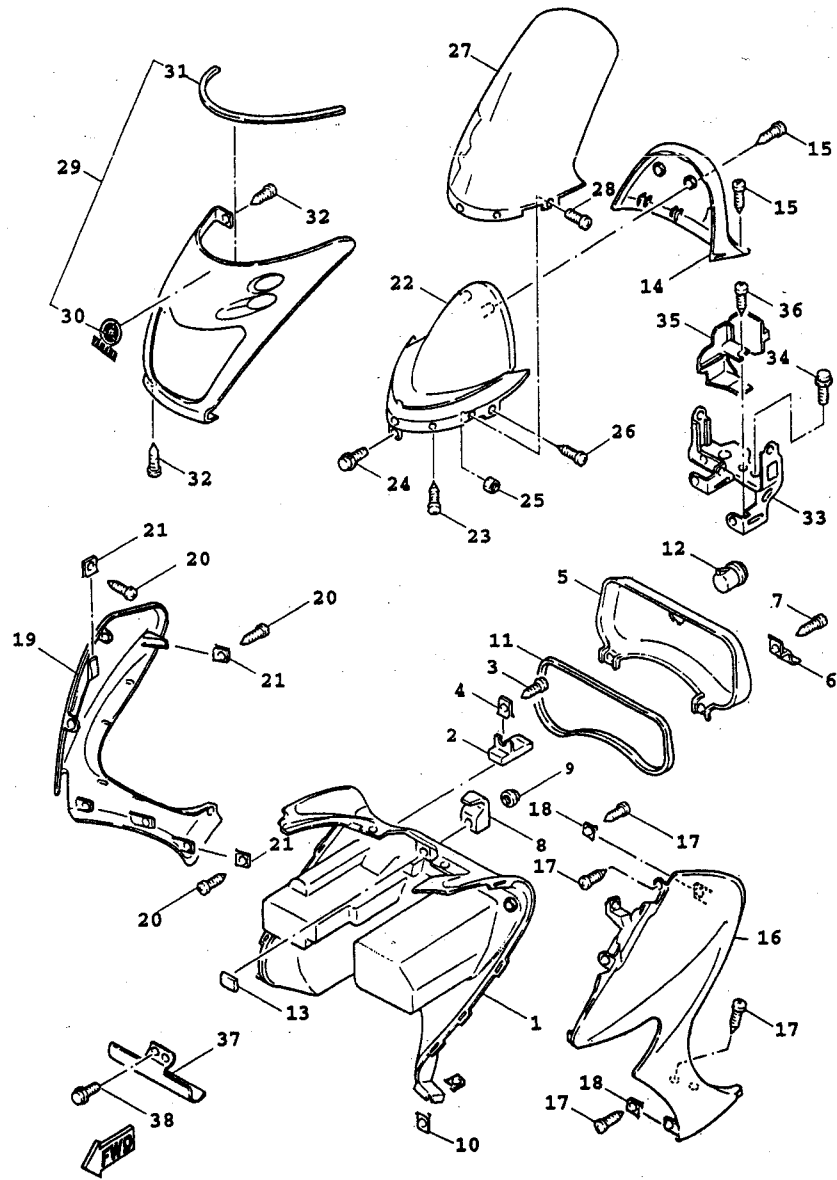

5CA7414-0340

FIG. 34 腳防護板 YP125C(5CA7)

項次	部品番號	英文名稱	中文名稱	用量	建議價格	備註	代碼	工時
18	90183-05807	NUT, SPRING	彈簧螺帽	7	5			
19	5CA-F835V-00-P6	PANEL 2	前蓋 2	1	650	用於黑車		
	5CA-F835V-00-1V	PANEL 2	前蓋 2	1	650	用於銀車		
	5CA-F835V-00-P4	PANEL 2	前蓋 2	1	650	用於深綠車		
20	97707-50016	SCREW, TAPPING	攻螺絲	7	3			
21	90183-05807	NUT, SPRING	彈簧螺帽	7	5			
22	5CA-F836K-00	PANEL, INNER 1	整流罩結合板	1	60			
23	97707-50016	SCREW, TAPPING	攻螺絲	2	3			
24	90119-06821	BOLT, WITH WASHER	六角套頭螺栓	1	5			
25	90179-05849	NUT	螺帽	5	7			
26	90159-05083	SCREW, WITH WASHER	螺絲附墊圈	2	3			
27	5CA-F837U-10	SCREEN	透明罩	1	1,300			
28	90150-05024	SCREW, ROUND HEAD	螺絲	5	15			
29	5CA-X2834-00-4B	MOLE 1	護板	1	350	黑色 2		
30	5CA-F8328-00	. EMBLEM	標誌	1				
31	5CA-F8347-00	. MOLE 3	護片 3	1	15			
32	97707-50016	SCREW, TAPPING	攻螺絲	4	3			
33	5CA-F8356-10	STAY 1	固定座 1	1	250			
34	95807-06012	BOLT, FLG	凸緣螺栓	2	3			

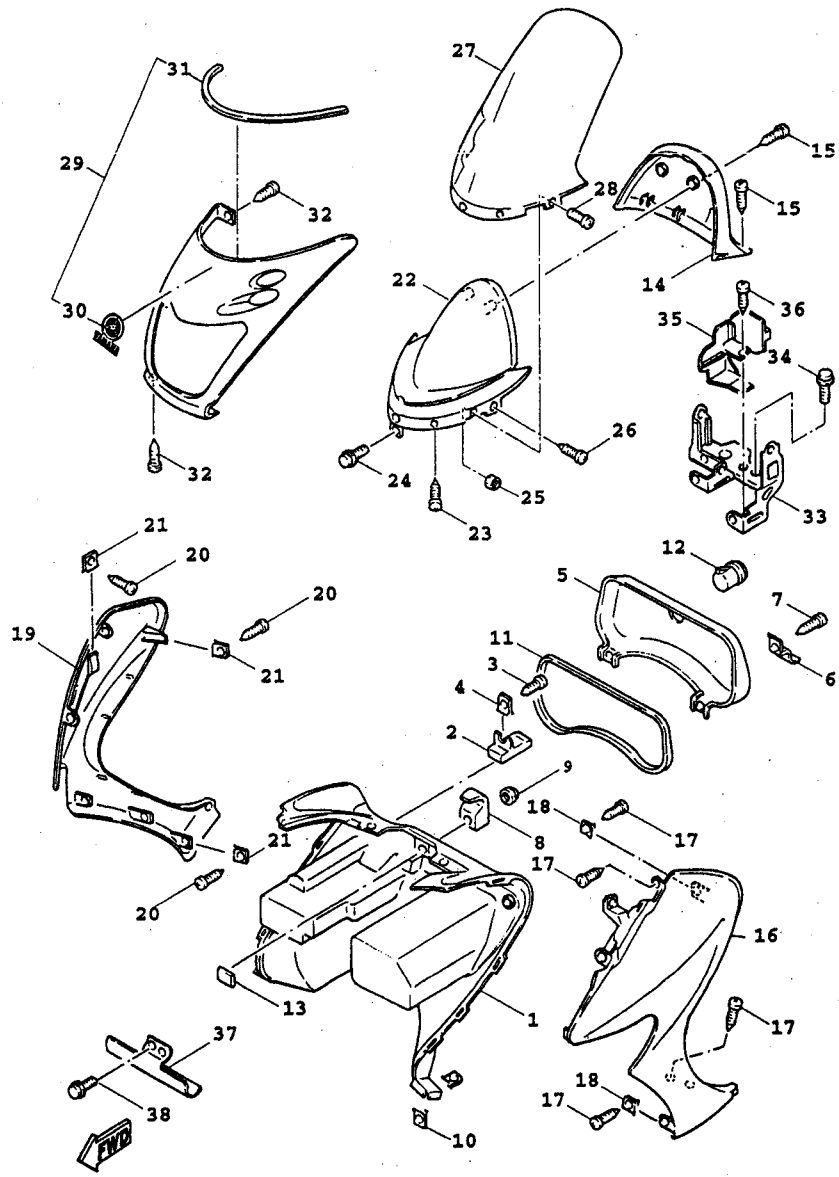

5CA7414-0340

FIG. 34 腳防護板 YP125C(5CA7)

項次	部品番號	英文名稱	中文名稱	用量	建議價格	備註	代碼	工時
35	5CA-F834V-00	PROTECTOR 1	護罩 1	1	20			
36	90159-06813	SCREW, WITH WASHER	螺絲附墊圈	1	3			
37	5CA-F834W-00	PROTECTOR 2	護罩 2	1	70			
38	95807-06014	BOLT, FLG	凸緣螺栓	2	3			

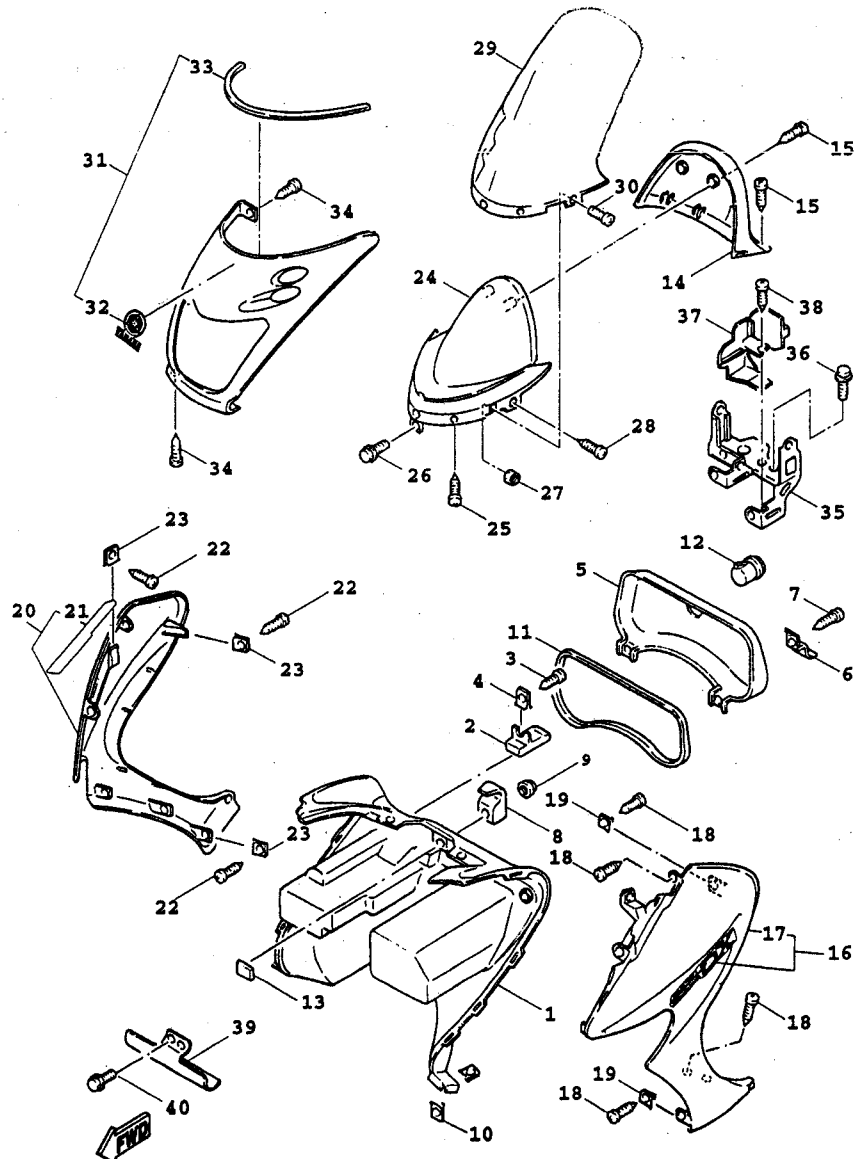

5CA5414-8271

FIG. 35 腳防護板 YP125A(5CA8)

項次	部品番號	英文名稱	中文名稱	用量	建議價格	備註	代碼	工時
1	5CA-F8311-00	LEG SHIELD 1	腳防護板 1	1	270	5CA8		
2	5CA-F8365-00	COVER	蓋	1	15			
3	97707-50016	SCREW, TAPPING	攻螺絲	1	3			
4	90183-05807	NUT, SPRING	彈簧螺帽	1	5			
5	5CA-F8313-00	LID	行李箱蓋	1	70			
6	1NT-F1796-00	HINGE	絞鏈	2	5			
7	97707-40512	SCREW, TAPPING	攻螺絲	2	3			
8	5CA-F8257-00	HOOK 1	鉤 1	1	10			
9	90176-06805	NUT, CROWN	有蓋螺帽	1	5			
10	90183-05807	NUT, SPRING	彈簧螺帽	4	5			
11	4TE-F8371-00	DAMPER	防震墊	1	5			
12	23Y-F1708-V0	SIDE COVER LOCK ASSY	箱蓋鎖	1	60			
13	1NT-F834V-00	PROTECTOR 1	護罩 1	1	3			
14	5CA-F836L-00	PANEL, INNER 2	內嵌板 2	1	80			
15	97707-50016	SCREW, TAPPING	攻螺絲	4	3			
16	5CA-X283U-20-4B	PANEL	前蓋	1	700	用於黑車		
	5CA-X283U-10-1V	PANEL	前蓋	1	700	用於銀車		
17	5CA-F832L-00	.GRAPHIC 13	圖案	1		用於黑車		
	5CA-F832L-10	.GRAPHIC 13	圖案	1		用於銀車		

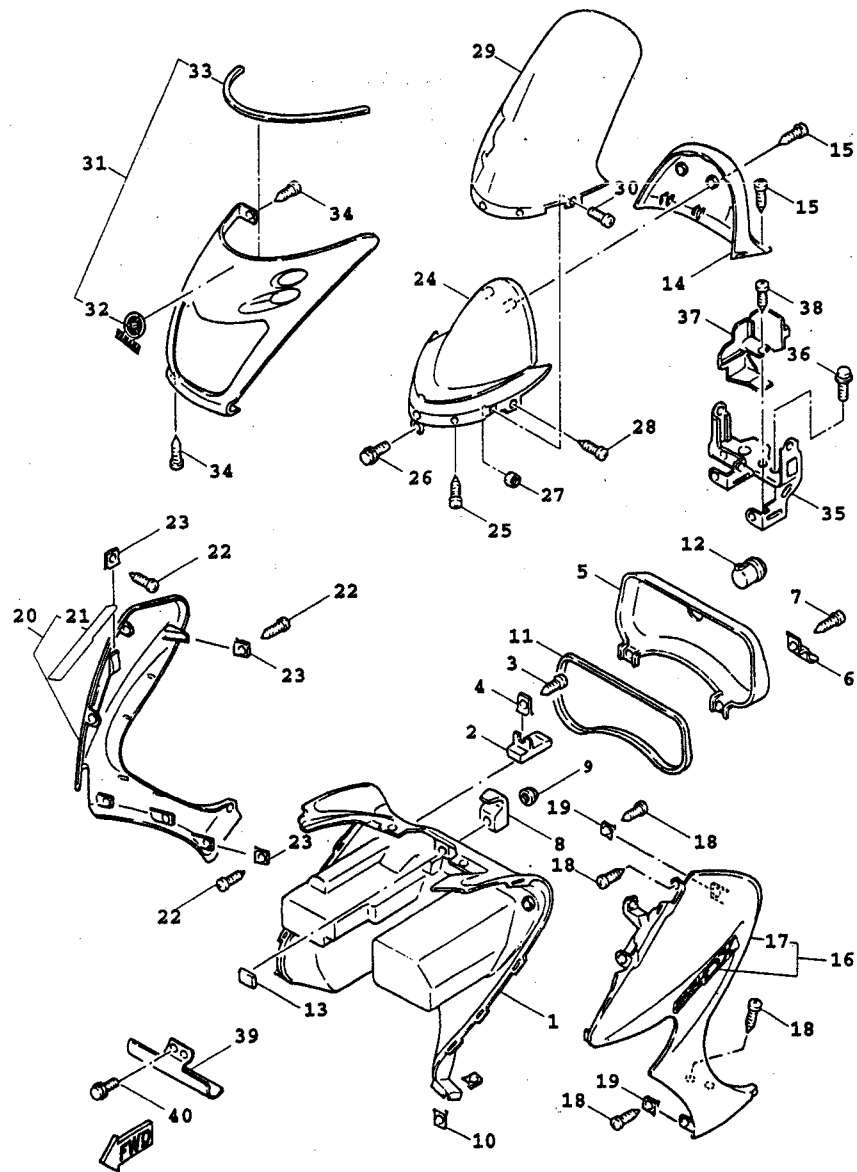

SCA5414-8271

FIG. 35 腳防護板 YP125A(5CA8)

項次	部品番號	英文名稱	中文名稱	用量	建議價格	備註	代碼	工時
18	97707-50016	SCREW, TAPPING	攻螺絲	7	3			
19	90183-05807	NUT, SPRING	彈簧螺帽	7	5			
20	5CA-X283V-20-4B	PANEL	前蓋	1	700	用於黑車		
	5CA-X283V-10-1V	PANEL	前蓋	1	700	用於銀車		
21	5CA-F832P-00	.GRAPHIC	圖案	1		用於黑車		
	5CA-F832P-10	.GRAPHIC	圖案	1		用於銀車		
22	97707-50016	SCREW, TAPPING	攻螺絲	7	3			
23	90183-05807	NUT, SPRING	彈簧螺帽	7	5			
24	5CA-F836K-00	PANEL, INNER 1	整流罩結合板	1	60			
25	97707-50016	SCREW, TAPPING	攻螺絲	2	3			
26	90119-06821	BOLT, WITH WASHER	六角套頭螺栓	1	5			
27	90179-05849	NUT	螺帽	5	7			
28	90159-05083	SCREW, WITH WASHER	螺絲附墊圈	2	3			
29	5CA-F837U-10	SCREEN	透明罩	1	1,300			
30	90150-05024	SCREW, ROUND HEAD	螺絲	5	15			
31	5CA-X2834-00-4B	MOLE 1	護板	1	350	黑色 2		
32	5CA-F8328-00	.EMBLEM	標誌	1				
33	5CA-F8347-00	.MOLE 3	護片 3	1	15			
34	97707-50016	SCREW, TAPPING	攻螺絲	4	3			

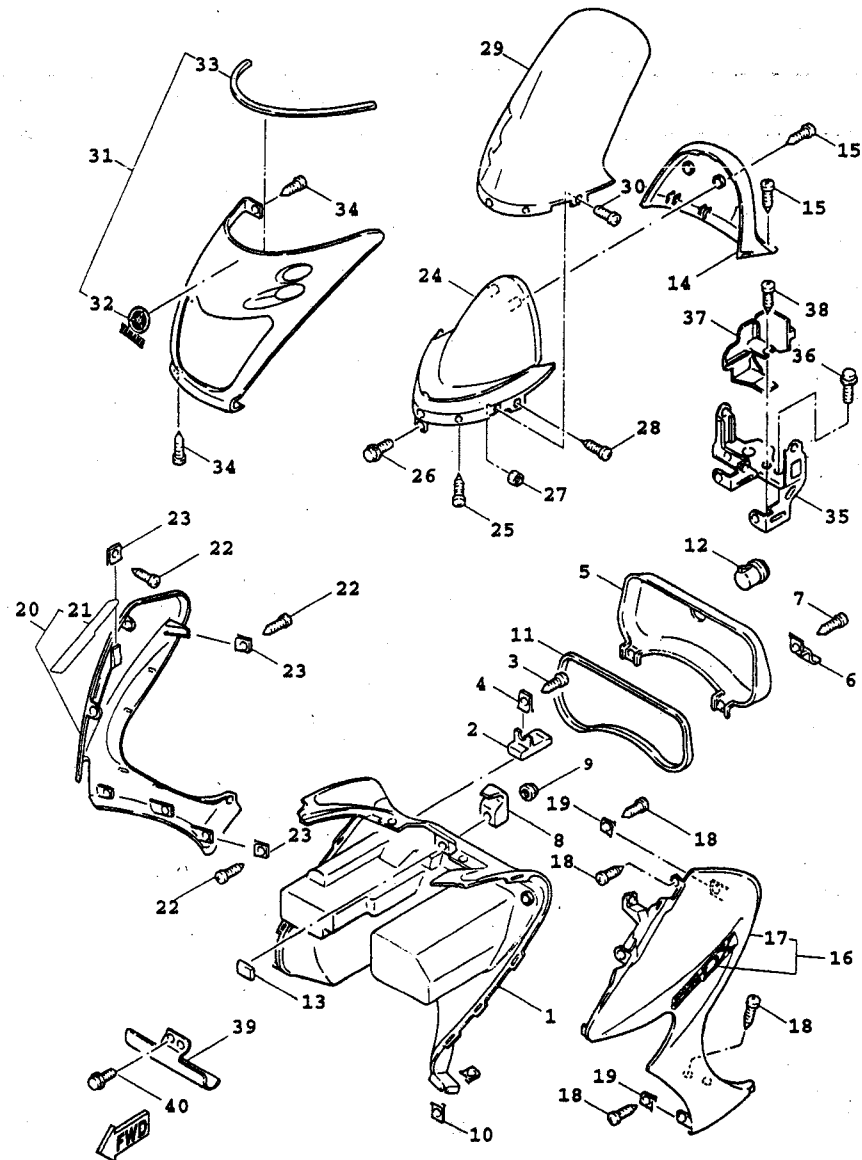

5CA5414-8271

FIG. 35 腳防護板 YP125A(5CA8)

項次	部品番號	英文名稱	中文名稱	用量	建議價格	備註	代碼	工時
35	5CA-F8356-10	STAY 1	固定座1	1	250			
36	95807-06012	BOLT, FLG	凸緣螺栓	2	3			
37	5CA-F834V-00	PROTECTOR 1	護罩1	1	20			
38	90159-06813	SCREW, WITH WASHER	螺絲附墊圈	1	3			
39	5CA-F834W-00	PROTECTOR 2	護罩2	1	70			
40	95807-06014	BOLT, FLG	凸緣螺栓	2	3			

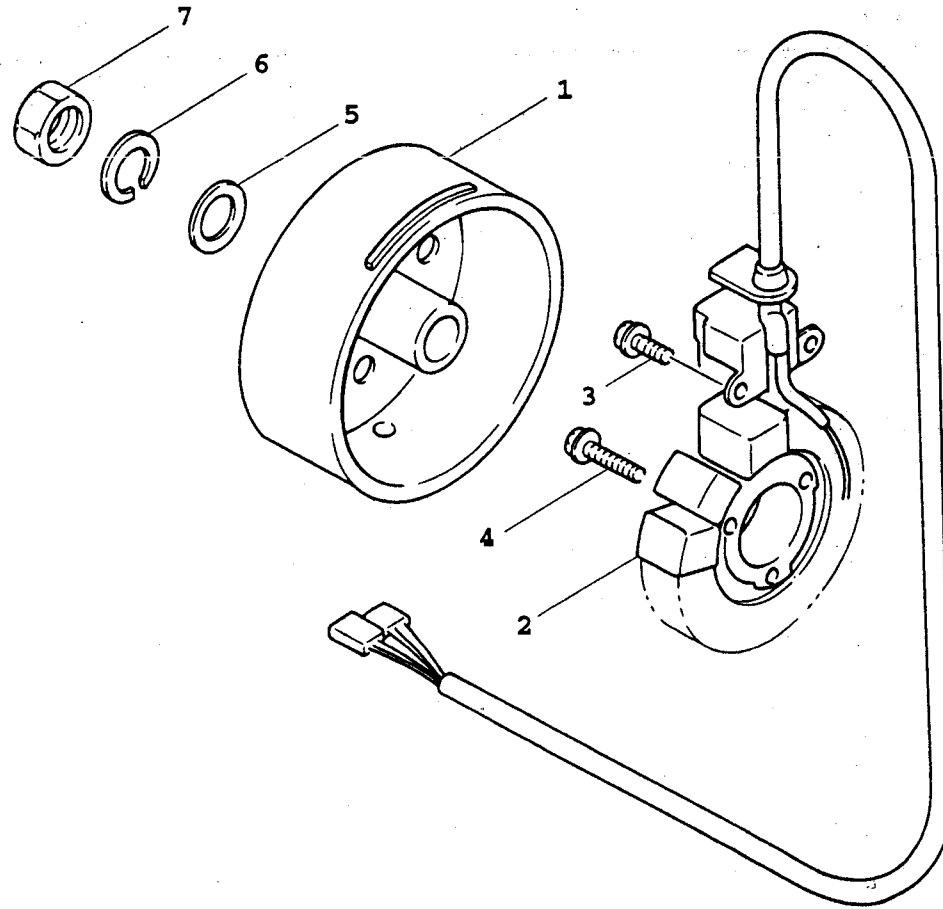

5CA1414-8280

FIG. 36 發電機

項次	部品番號	英文名稱	中文名稱	用量	建議價格	備註	代碼	工時
1	5CA-H5550-00	ROTOR ASSY	轉子總成	1	650			
2	5CA-H5510-00	STATOR ASSY	電樞總成	1	1,600			
3	97607-06216	SCREW, W/WASHER	六角螺栓附墊圈	2	3			
4	97607-06230	SCREW, W/WASHER	六角螺栓附墊圈	3	5			
5	92907-12600	WASHER, PLATE	平墊圈	1	3			
6	92907-12100	WASHER, PLATE	平墊圈	1	3			
7	90170-12181	NUT	六角螺帽	1	8			

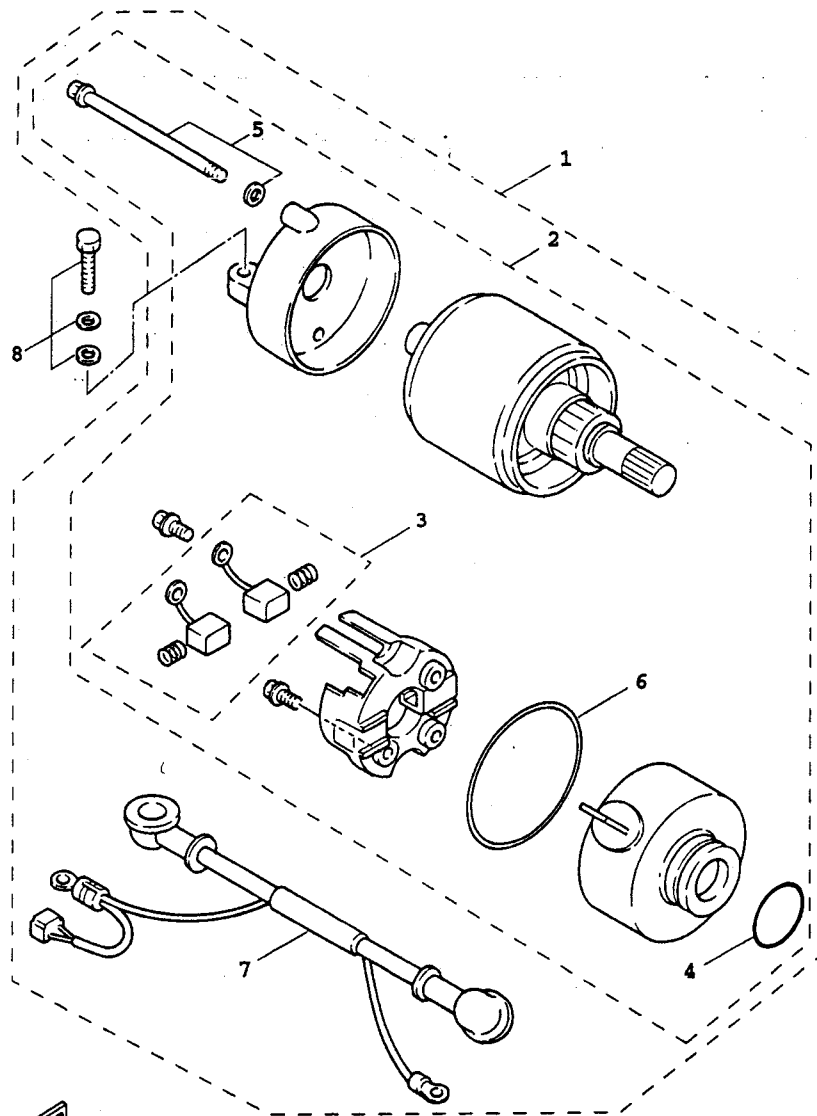

5CA1414-8290

FIG. 37 起動馬達

項次	部品番號	英文名稱	中文名稱	用量	建議價格	備註	代碼	工時
1	5CA-H1800-00	STARTING MOTOR ASSY	起動馬達總成	1	2,100			
2	4CB-W8180-00	.STARTING MOTOR SET	起動馬達組	1	2,160			
3	3KW-H1801-00	..BRUSH SET	碳刷組	1	130			
4	3KW-H1861-00	..GASKET	墊片	1	23			
5	3UH-H1828-01	..BOLT 2	螺栓	1	11			
6	93210-26668	..O-RING	護油圈	1	7			
7	5CA-H183G-00	.CORD COMP.	起動馬達線	1	200			
8	97507-06525	BOLT,W/WASHER	六角螺栓附墊圈	2	5			

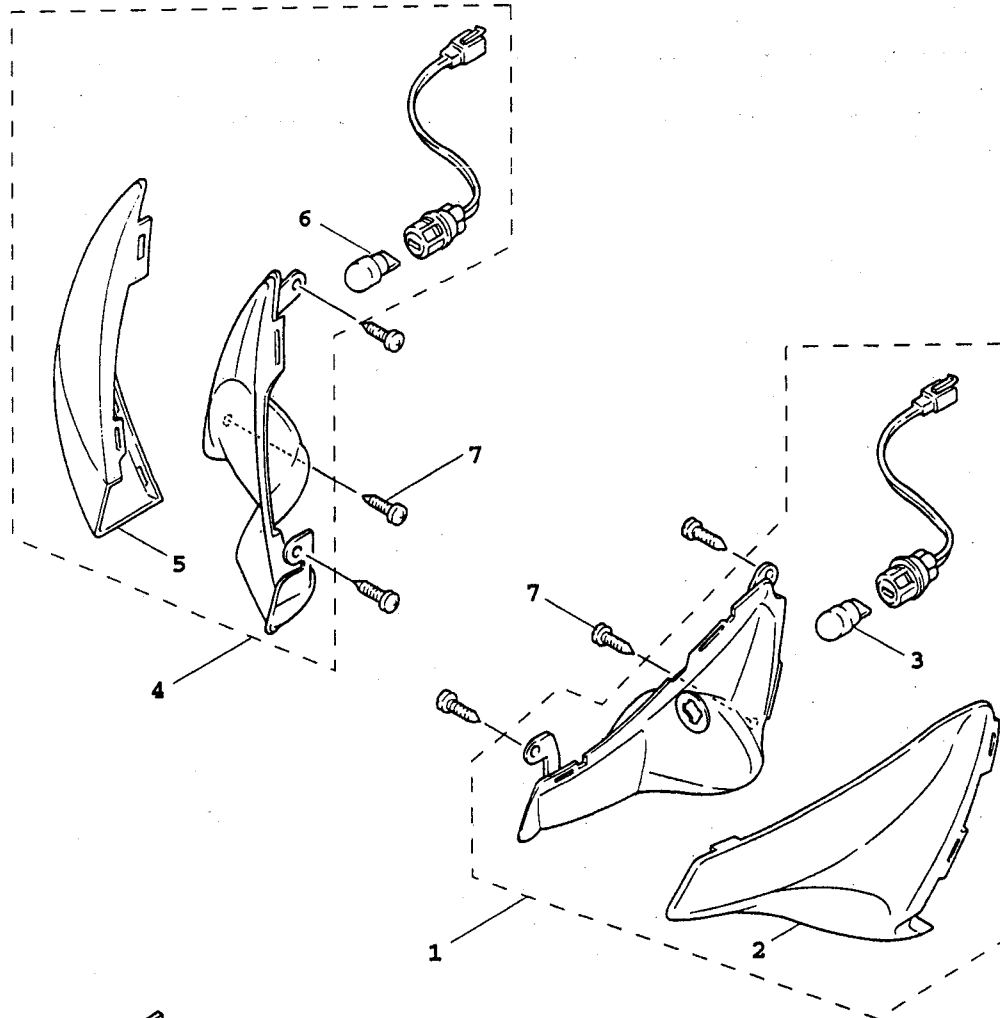

5CA1414-8300

FIG. 38 方向燈

項次	部品番號	英文名稱	中文名稱	用量	建議價格	備註	代碼	工時
1	5CA-H3310-00	FRONT FLASHER LIGHT ASSY	前方向燈總成 1	1	110	5CA4, 5CA7		
	5CA-H3310-10	FRONT FLASHER LIGHT ASSY	前方向燈總成 1	1	110	5CA8		
2	5CA-H3312-00	.LENS, FLASHER	方向燈燈罩 1	1	30	5CA4, 5CA7		
	5CA-H3312-10	.LENS, FLASHER	方向燈燈罩 1	1	30	5CA8		
3	3XG-H3311-00	.BULB, FLASHER	方向燈泡	1	25			
4	5CA-H3320-00	FRONT FLASHER LIGHT ASSY	前方向燈總成 2	1	110	5CA4, 5CA7		
	5CA-H3320-10	FRONT FLASHER LIGHT ASSY	前方向燈總成 2	1	110	5CA8		
5	5CA-H3322-00	.LENS, FLASHER 2	方向燈燈罩 2	1	30	5CA4, 5CA7		
	5CA-H3322-10	.LENS, FLASHER 2	方向燈燈罩 2	1	30	5CA8		
6	3XG-H3311-00	.BULB, FLASHER	方向燈泡	1	25			
7	97707-50016	SCREW, TAPPING	攻螺絲	6	3			

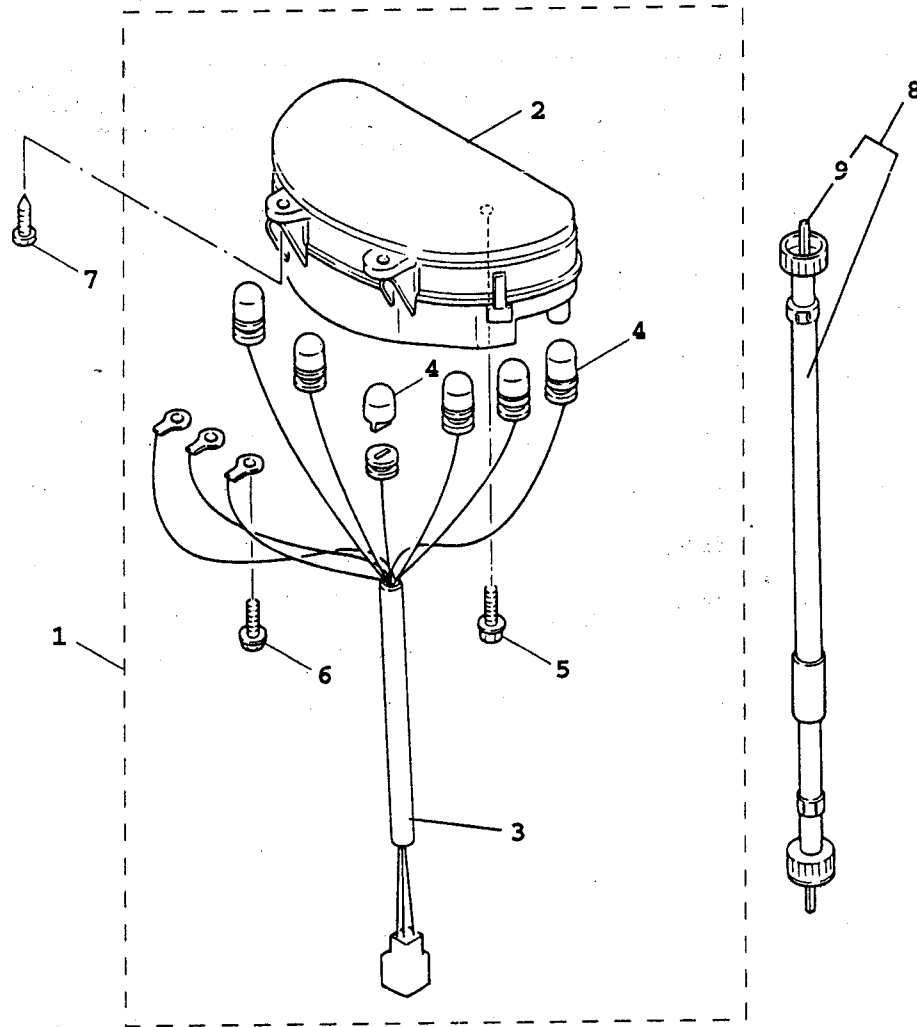

5CA1414-8310

FIG. 39 計量表

項次	部品番號	英文名稱	中文名稱	用量	建議價格	備註	代碼	工時
1	5CA-H3500-21	SPEEDOMETER ASSY	計量表總成	1	6,300	5CA4		
	5CA-H3500-30	SPEEDOMETER ASSY	計量表總成	1	6,300	5CA8		
	5CA-H3500-00	SPEEDOMETER ASSY	計量表總成	1	1,300	5CA7		
2	5CA-H3511-00	.LENS, SPEEDOMETER	速度錶蓋	1	75	5CA7		
3	5CA-H3509-00	.SOCKET CORD ASSY	燈座總成	1	150	5CA7		
4	3KW-H3517-00	.BULB	計量表燈泡	6	10	5CA7		
5	97607-04312	.SCREW, W/WASHER	六角螺栓附墊圈	3	5	5CA7		
6	90159-03102	.SCREW, WITH WASHER	螺絲附墊圈	3	3	5CA7		
7	97707-50016	SCREW, TAPPING	攻螺絲	4	3			
8	5CA-H3550-00	SPEEDOMETER CABLE ASSY	速度錶鋼索總成	1	50	5CA7		
9	5CA-H3550-10	SPEEDOMETER CABLE ASSY	速度錶鋼索總成	1	50	5CA4, 5CA8		
10	5CA-H3551-00	.WIRE, SPEEDOMETER CABLE	速度錶內線	1	20			

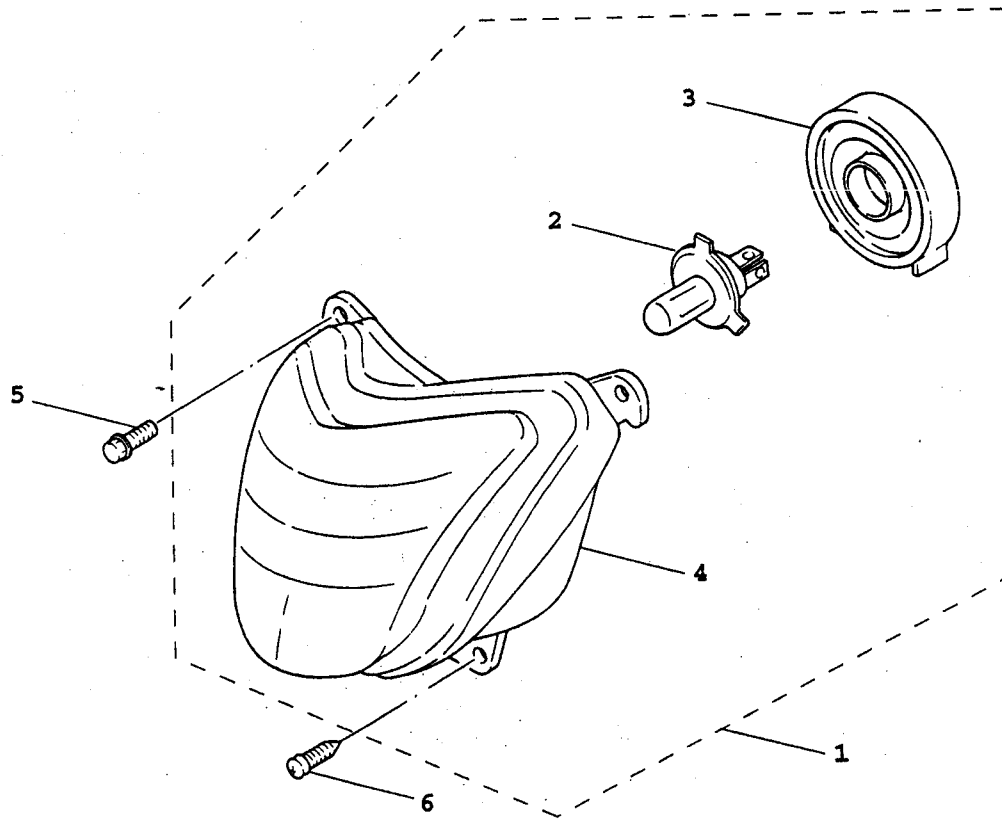

5CA1414-8321

FIG. 40 前燈

項次	部品番號	英文名稱	中文名稱	用量	建議價格	備註	代碼	工時
1	5CA-H4310-00	HEADLIGHT UNIT ASSY	前燈總成	1	900			
2	3YB-H4314-00	.BULB, HEADLIGHT	前燈泡	1	210			
3	5CA-H4396-00	.COVER	蓋	1	50			
4	5CA-H430A-00	.HEADLIGHT NUIT	前燈單元	1	650			
5	90119-06806	BOLT, WITH WASHER	六角套頭螺栓	2	5			
6	97707-50016	SCREW, TAPPING	攻螺絲	2	3			

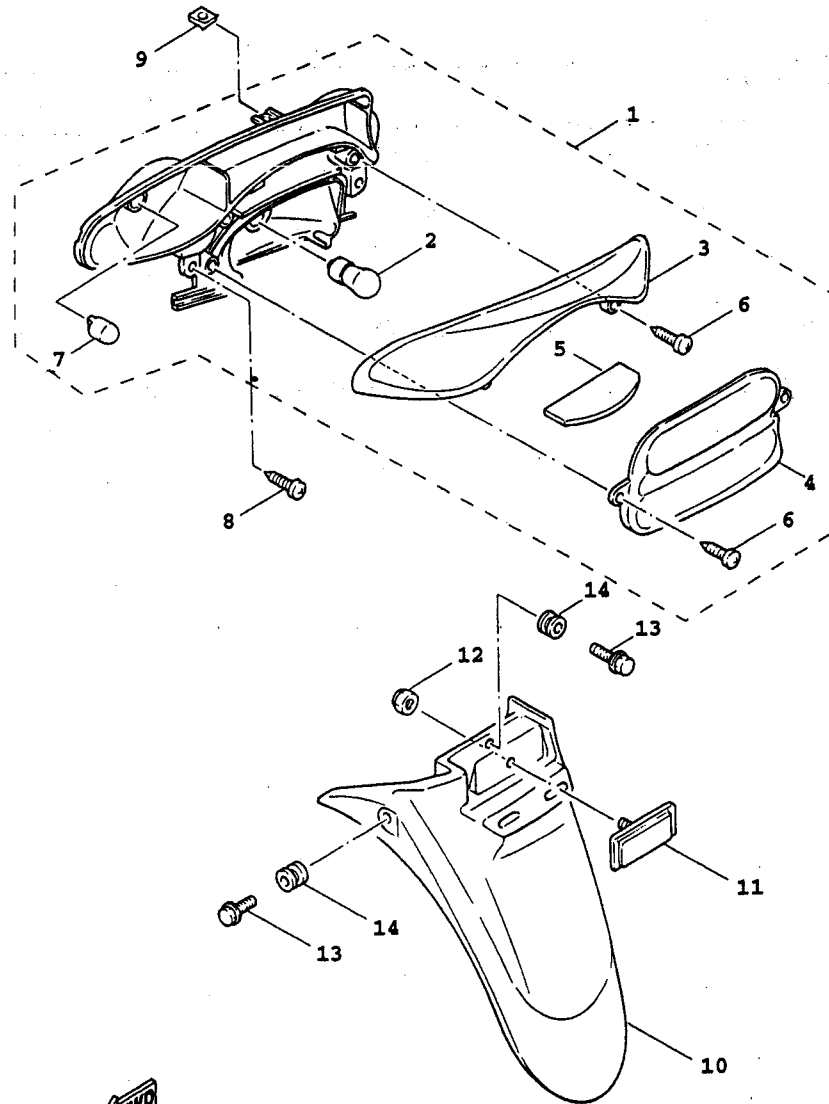

5CA1414-8330

FIG. 41 後燈

項次	部品番號	英文名稱	中文名稱	用量	建議價格	備註	代碼	工時
1	5CA-H4710-00	TAILLIGHT UNIT ASSY	後燈單元總成	1	450	5CA4, 5CA7		
	5CA-H4710-10	TAILLIGHT UNIT ASSY	後燈單元總成	1	450	5CA8		
2	4TE-H4714-00	.BULB	後燈泡	1	25			
3	5CA-H3332-00	.LENS, FLASHER	後方向燈燈罩1	1	60	5CA4, 5CA7		
	5CA-H3332-10	.LENS, FLASHER	後方向燈燈罩1	1	60	5CA8		
4	5CA-H4721-00	.LENS, TAILLIGHT	後燈燈罩	1	55			
5	5CA-H4743-00	.LENS, LICENCE LIGHT	牌照燈罩	1	15			
6	97707-04616	.SCREW TAPPING	攻螺絲	4	5			
7	3XG-H3311-00	.BULB, FLASHER	方向燈泡	2	25			
8	97707-50016	SCREW, TAPPING	攻螺絲	2	3			
9	90183-05807	NUT, SPRING	彈簧螺帽	1	5			
10	5CA-F1685-00	BRACKET, LICENSE	牌照支架	1	70			
11	3KW-H5130-00	REAR REFLECTOR ASSY	後反射鏡總成	1	30			
12	95707-05500	NUT, FLG	凸緣螺帽	1	3			
13	95807-06014	BOLT, FLG	凸緣螺栓	3	3			
14	90387-068W4	COLLAR	軸環	3	5			

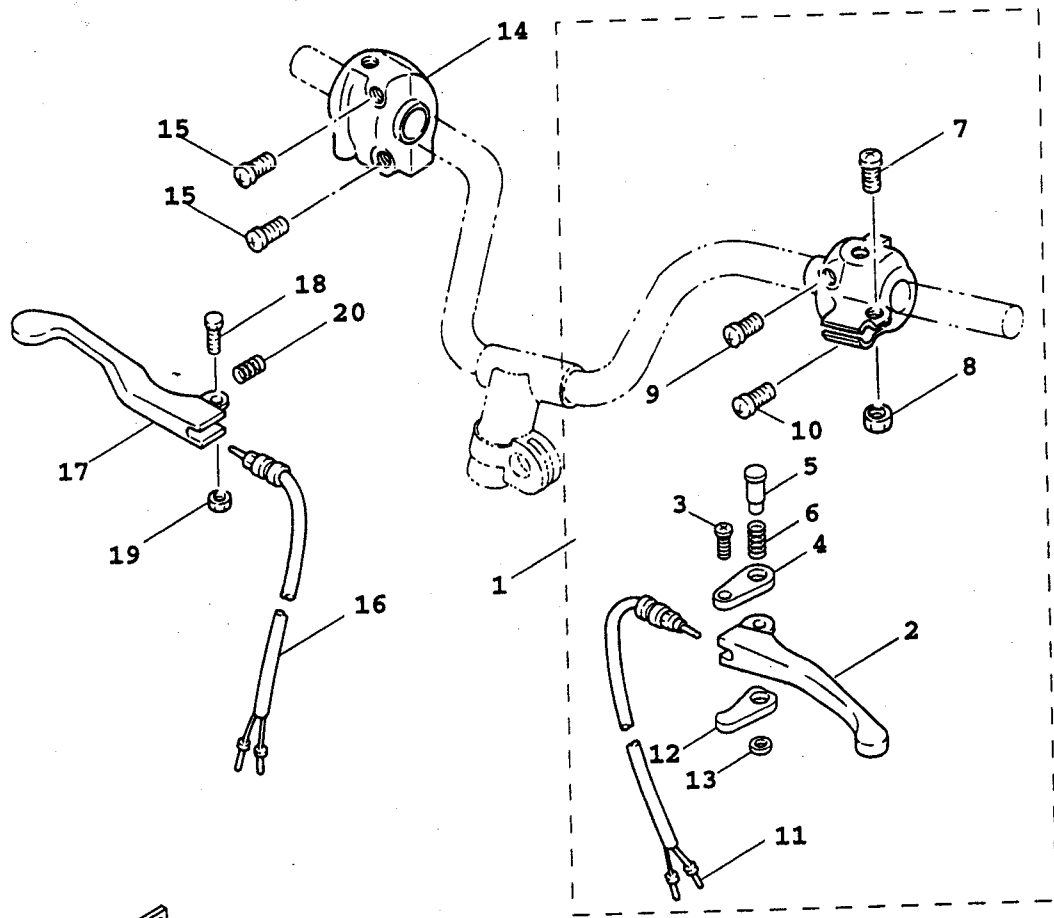

5CA1414-8341

FIG. 42 把手開關，把手

項次	部品番號	英文名稱	中文名稱	用量	建議價格	備註	代碼	工時
1	5CA-H2910-10	LEVER HOLDER ASSY (LEFT)	左把手控制座總成	1	480			
2	5CA-H3912-10	.LEVER 1	左把手	1	80			
3	97607-03108	..SCREW, W/WASHER	六角螺栓附墊圈	1				
4	5CA-H3935-00	..COVER	蓋	1				
5	5CA-H396K-00	..BUTTON	按鈕	1				
6	5CA-H3962-00	..SPRING	彈簧	1				
7	3XG-H3915-00	.SCREW, LEVER FITTING	固定螺栓	1	5			
8	95607-05100	.NUT, U	U型螺帽	1	8			
9	98507-05020	.SCREW, PAN HEAD	盤頭螺絲	1	3			
10	98507-05030	.SCREW, PAN HEAD	盤頭螺絲	1	3			
11	3XG-H3980-01	.FRONT STOP SWITCH ASSY	前剎車燈開關總成	1	25			
12	5CA-H2588-00	.PLATE	板	1	50			
13	92907-05600	.WASHER, PLATE	平墊圈	1				
14	5CA-H3975-10	SWITCH, HANDLE 2	把手開關	1	300			
15	98507-05025	.SCREW, PAN HEAD	盤頭螺絲	2	5			
16	3GF-H3980-00	FRONT STOP SWITCH ASSY	前剎車燈開關總成	1	24			
17	4VP-H3922-00	LEVER 2	右把手	1	40			
18	90109-06577	BOLT	螺栓	1	5			
19	95607-06100	NUT, U	U型螺帽	1	8			

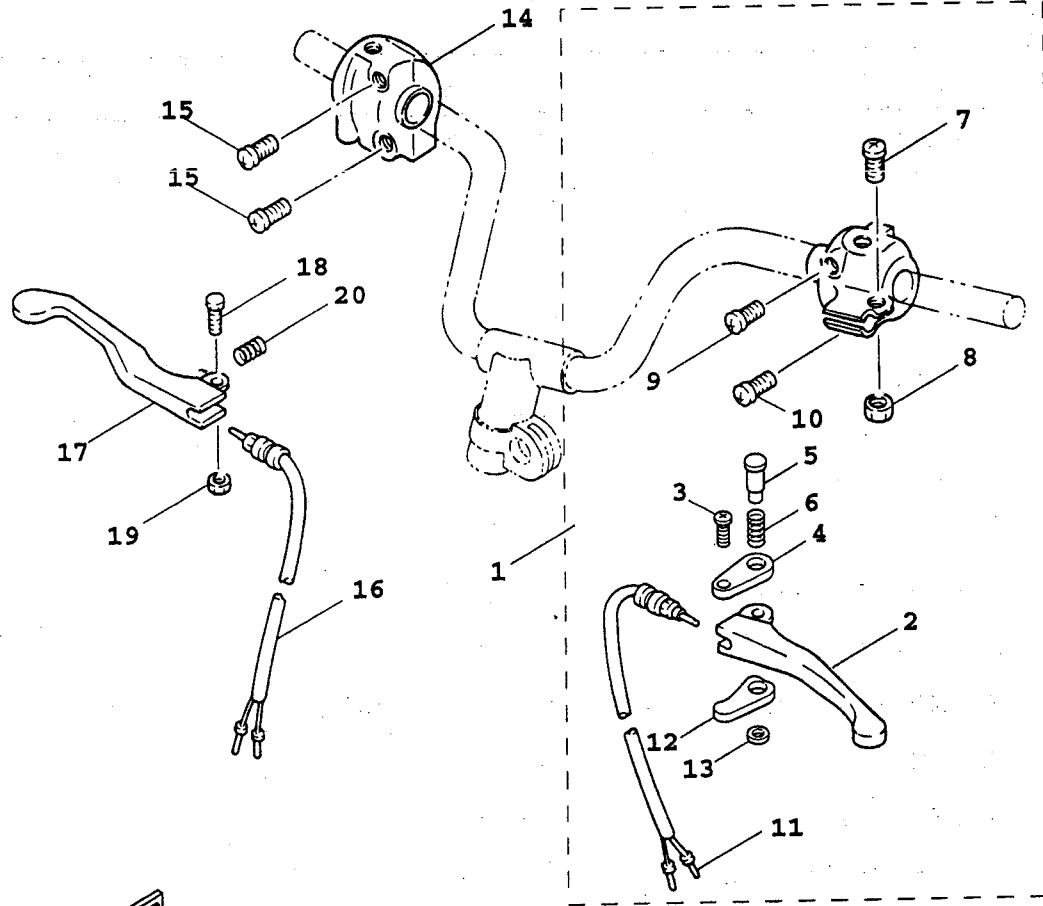

5CA1414-8341

FIG. 42 把手開關，把手

項次	部品番號	英文名稱	中文名稱	用量	建議價格	備註	代碼	工時
20	90501-10312	SPRING, COMPRESSION	壓力彈簧	1	5			

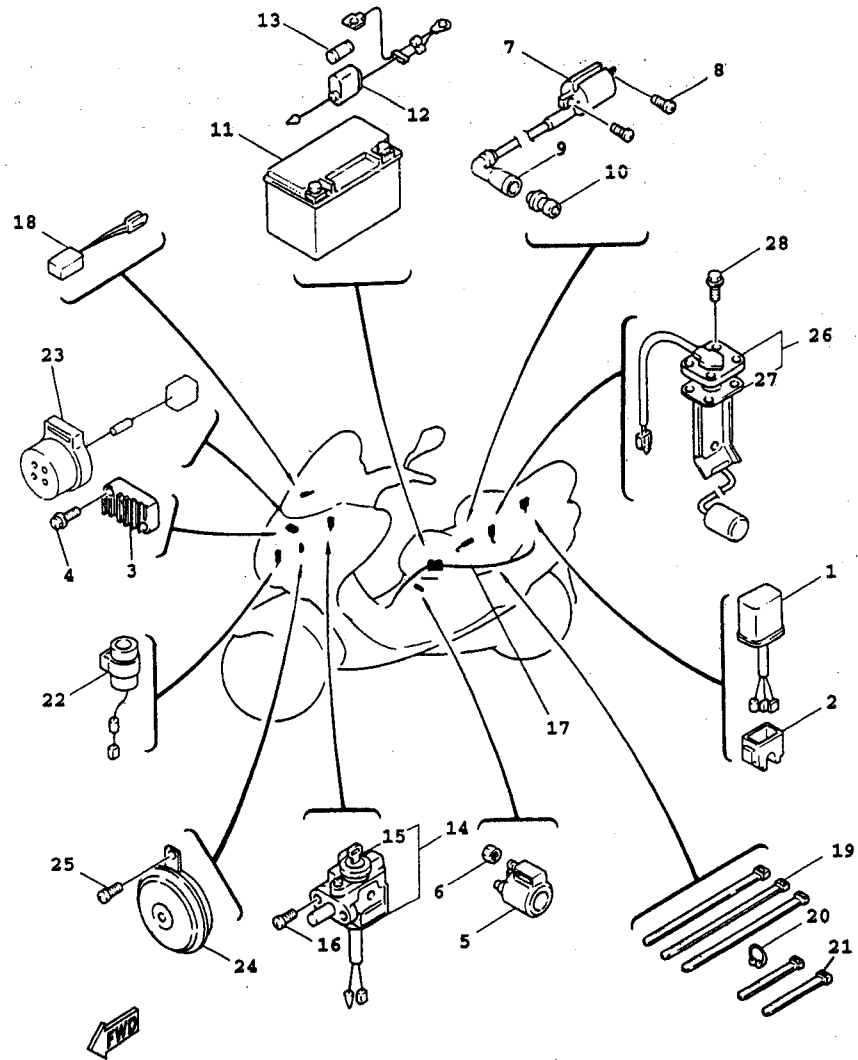

5CA1414-8351

FIG. 43 電裝1

項次	部品番號	英文名稱	中文名稱	用量	建議價格	備註	代碼	工時
1	5CA-H5540-00	C.D.I. UNIT ASSY	C.D.I 組件總成	1	1,300	5CA4, 5CA7		
	5CA-H5540-10	C.D.I. UNIT ASSY	C.D.I 組件總成	1	2,450	5CA8		
2	4KP-H5546-00	BAND	束帶	1	20	5CA4, 5CA7		
	5CA-H5546-00	BAND	束帶	1	20	5CA8		
3	5AG-H1960-00	RECTIFIER & REGULATOR ASSY	整流器調整器總成	1	770			
4	97607-05225	SCREW, W/WASHER	六角螺栓附墊圈	2	3			
5	4CW-H1940-01	STARTER RELAY ASSY	起動繼電器	1	185			
6	95307-06700	NUT, HEXAGON	六角螺帽	2	3			
7	5CA-H2310-00	IGNITION COIL ASSY	點火線圈總成	1	350			
8	98507-06018	SCREW, PAN HEAD	盤頭螺絲	2	3			
9	4CW-H2370-00	PLUG CAP ASSY	火星塞蓋總成	1	45			
10	4CW-H2372-00	SEAL, PLUG CAP	火星塞蓋封圈	1	13			
11	4CB-H2100-00	BATTERY ASSY	蓄電池總成	1	1,000			
12	5CA-H2150-00	FUSE HOLDER ASSY	保險絲盒總成	1	130			
13	2GE-H2151-00	.FUSE	保險絲	2	5			
14	5CA-H2501-01	MAIN SWITCH STEERING LOCK	主開關舵鎖總成	1	420	5CA4, 5CA7		
	5CA-H2501-10	MAIN SWITCH STEERING LOCK	主開關舵鎖總成	1	1,300	5CA8		
15	4TE-H2552-00	.CAP, SWITCH	開關蓋	1	10	5CA4, 5CA7		
	4TE-H2552-10	.CAP, SWITCH	開關蓋	1	10	5CA8		

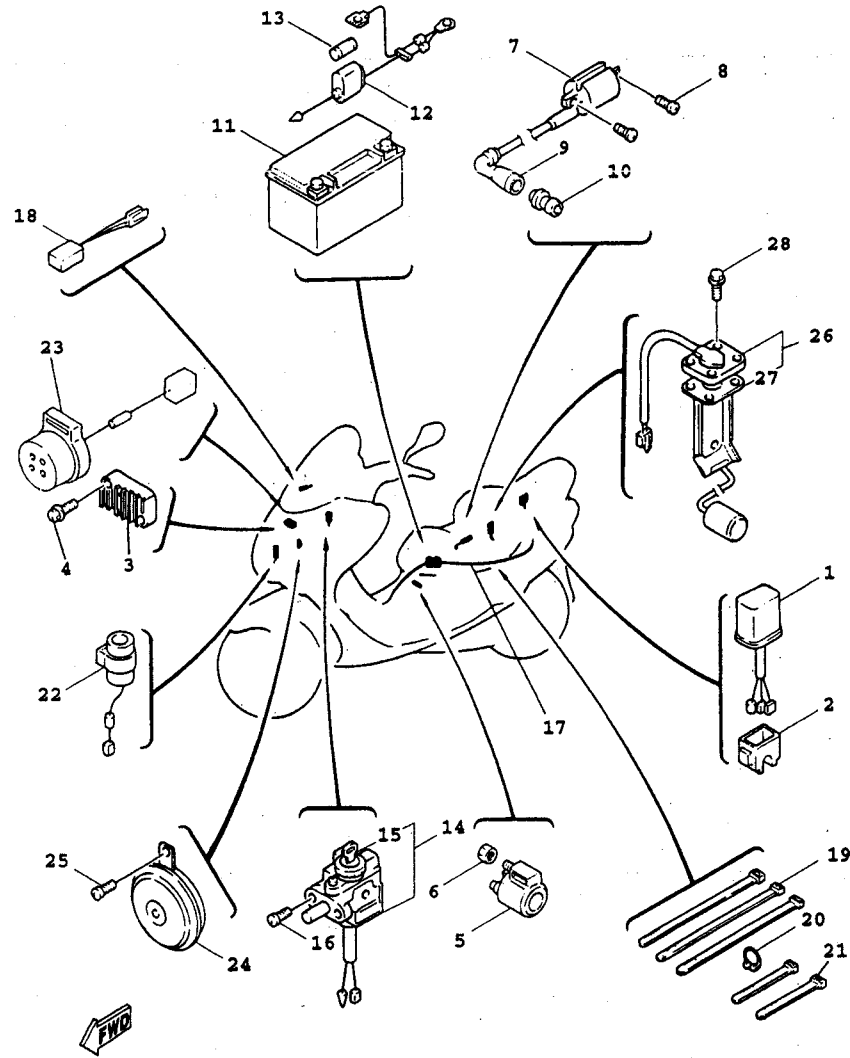

5CA1414-8351

FIG. 43 電裝1

項次	部品番號	英文名稱	中文名稱	用量	建議價格	備註	代碼	工時
16	98507-06012	SCREW, PAN HEAD	盤頭螺絲	2	3			
17	5CA-H2590-20	WIRE HARNESS ASSY	電線總成	1	440	5CA4		
	5CA-H2590-30	WIRE HARNESS ASSY	電線總成	1	440	5CA8		
	5CA-H2590-40	WIRE HARNESS ASSY	電線總成	1		5CA7		
18	5CA-H1980-00	RECTIFIER 2	整流器	1	70			
19	90464-12812	CLAMP	夾	3	14			
20	90464-23811	CLAMP	夾	1	7			
21	90464-15840	CLAMP	夾	2	15			
22	5CA-H3350-00	FLASHER RELAY ASSY	方向斷續器總成	1	230			
23	3XY-H3390-01	AUDIO PILOT ASSY	嚮導警報器總成	1	85			
24	4KP-H3371-01	HORN	喇叭	1	80			
25	98507-06010	SCREW, PAN HEAD	盤頭螺絲	1	3			
26	5CA-X8575-00	SENDER ASSY	油面感應器總成	1	170			
27	53X-H5753-00	.GASKET, SENDER UNIT	墊片	1	8			
28	90119-05071	BOLT, WITH WASHER	六角套頭螺栓	4	3			
29	5CA-82021-01	KEY SET	鎖整組	1	600	5CA4, 5CA7		
	5CA-82021-20	KEY SET	鎖整組	1	1,600	5CA8		

部品番號索引

部品番號	項次	部品番號	項次	部品番號	項次	部品番號	項次	部品番號	項次	部品番號	項次
5CA-E1102-00	1- 1	5CA-E2481-00	5-13	4CW-E4806-00	9-40	5CA-E5471-00	10-29	5CA-F1398-00	24-38	5CA-F1731-00	20-11
3UH-E111F-00	3-21	5CA-E2482-00	5-14	5CA-E4849-00	9-33	5CA-E5472-00	10-30	5CA-F1410-00	14- 5	5CA-F174F-00	30-31
5CA-E1166-00	4-13	5CA-E2483-00	5-15	3UH-E4871-10	1- 5	4DM-E5481-00	10-39	5CA-F1420-11	14- 2	5CA-F174F-00	31-29
5DS-E1185-00	4- 6	5CA-E2576-00	5-23	5CA-E4872-00	9-24	5CA-E5521-00	11- 3	4CW-F1481-00	14- 3	5CA-F174F-00	32-31
3KW-E1186-00	1- 8	5CA-E2590-00	5-10	5CA-E4876-00	9-26	5CA-E5524-00	11- 7	5CA-F1511-01-P4	16- 1	5CA-F174G-00	20- 2
5CA-E1351-00	1-17	5CA-E3300-00	6- 1	5CA-E4883-00	9-29	3UH-E5532-00	11- 5	5CA-F1511-01-P6	16- 1	5CA-F174G-10	20- 2
5CA-E1400-00	2- 1	3UH-E3324-00	2- 9	5CA-E4884-00	9-35	4CW-E5570-00	11-10	5CA-F1511-01-P7	15- 1	5CA-F174H-00	20- 3
5CA-E1422-00	2- 6	3UH-E3325-00	6- 2	5CA-E4885-00	9-36	4CW-E5601-00	11-12	5CA-F1511-01-1V	15- 1	5CA-F174H-10	20- 3
3UH-E1445-00	2- 8	3KW-E3411-00	6- 9	5CA-E4901-00	8- 1	4CW-E5620-00	11-18	5CA-F1511-01-1V	16- 1	5CA-F174J-00	20- 7
5CA-E1603-00	2-15	3UH-E3416-00	10-11	5CA-E5111-00	10- 1	4CW-E5630-00	11-20	5CA-F1511-01-1V	17- 1	5CA-F174J-10	20- 7
5CA-E1631-00	2-12	5CA-E3451-00	2-10	5CA-E5138-00	10- 3	5CA-E5650-00	11- 1	5CA-F1511-01-4B	17- 1	5CA-F174K-00	20- 8
3UH-E1633-00	2-13	5CA-E3542-00	9-38	5CA-E5191-00	10-26	3UH-E5657-00	12-11	1MH-F1518-00	15- 2	5CA-F174K-10	20- 8
5CA-E1651-00	2- 5	5CA-E3575-00	7- 4	5CA-E5316-00	10-34	4CW-E5659-00	11-22	1MH-F1518-00	16- 2	5CA-F1741-00-P4	19-14
5CA-E1681-00	2- 3	5CA-E3585-00	7- 1	4CW-E5317-00	14- 8	4CW-E5673-00	11-21	1MH-F1518-00	17- 2	5CA-F1741-00-P6	19-14
3UH-E1951-00	4-11	5CA-E3910-00	7-23	5CA-E5326-00	10-35	4CW-E5687-00	11-13	5CA-F1521-00	14-13	5CA-F1741-00-P7	18-14
3UH-E2111-01	3- 1	5CA-E3929-00	7-28	5CA-E5335-00	10-36	5CA-E6111-00	12- 1	5CA-F1523-00	15- 8	5CA-F1741-00-1V	18-14
3UH-E2121-00	3- 2	4CW-E4293-00	8-31	5CA-E5337-00	10-37	4CW-E6611-00	12- 4	5CA-F1523-00	16- 8	5CA-F1741-00-1V	19-14
3UH-E2156-00	3-11	5CA-E4294-00	7-25	3UH-E5351-00	6- 8	4TE-E6620-00	12-26	5CA-F1523-00	17- 8	5CA-F1741-00-1V	20-16
4CW-E2157-00	3-25	5CA-E4410-00	7- 5	4Y4-E5363-00	10-16	4CW-E6626-00	12-27	5CA-F1552-00	15- 5	5CA-F1741-00-4B	20-16
5CA-E2170-01	3-12	5CA-E4412-00	7- 7	5CA-E5363-00	10-57	5CA-E7211-00	13- 5	5CA-F1552-00	16- 5	4TE-F1753-00	23-28
3UH-E2176-00	3-13	5CA-E4425-00	7-19	5CA-E5371-00	10- 5	5CA-E7410-00	13- 1	5CA-F1552-00	17- 5	5CA-F1785-00	19- 2
4CW-E2210-01	3-18	5CA-E4426-00	7-20	5CA-E5373-00	10- 6	5CA-E7421-00	13- 4	5CA-F1557-00	30-27	5CA-F1785-00	19- 6
4DH-E2213-01	3-19	4TE-E4451-00	7- 9	4CW-E5379-00	10-38	4HP-E7611-00	12-17	5CA-F1557-00	31-25	5CA-F1785-10	19- 2
5CA-E2231-00	3-16	5CA-E4452-00	7-11	5CA-E5407-00	10-31	5CA-E7620-00	12- 6	5CA-F1557-00	32-27	5CA-F1785-10	19- 6
5CA-E2241-00	3-17	5CA-E4476-00	7-10	5CA-E5411-00	10-22	4CW-E7623-00	12- 9	5CA-F1611-00	15-10	5CA-F1785-20	19- 2
5CA-E2279-00	3-24	5CA-E4610-00-98	9- 1	5CA-E5417-00	10-40	4TE-E7632-00	12- 8	5CA-F1611-00	16-10	5CA-F1785-20	19- 6
5CA-E240A-00	5- 6	3UH-E4613-00	9-11	5CA-E542A-00	10-50	3UH-E7660-00	12-19	5CA-F1611-00	17-10	5CA-F1786-00	18- 2
5CA-E2405-00	5- 8	5CA-E4627-00	9-18	5CA-E542B-00	10-51	4CW-E7664-00	12-23	5CA-F1639-00	15-11	5CA-F1786-10	18- 2
5CA-E2413-00	5- 2	3UH-E4651-00	1- 4	5CA-E542C-00	10-52	5CA-E7670-00	12-20	5CA-F1639-00	16-11	5CA-F1787-00	18- 6
5DS-E2420-00	4- 1	5CA-E4708-01	9- 2	5CA-E5421-00	10-18	3UH-E7684-00	12-25	5CA-F1639-00	17-11	5CA-F1787-10	18- 6
5DS-E2422-00	4- 4	5CA-E4728-00	9- 7	5CA-E5426-00	10-48	5CA-F1110-00-33	14- 1	5CA-F1685-00	41-10	1NT-F1796-00	33- 6
4DH-E2428-00	4- 5	4CW-E4766-00	9-15	5CA-E5431-00	10-33	5CA-F1110-10-33	14- 1	23Y-F1708-V0	33-12	1NT-F1796-00	34- 6
3UH-E2450-00	4- 2	5CA-E4766-00	9- 9	5CA-E5451-00	10-23	5CA-F1161-00	30-29	23Y-F1708-V0	34-12	1NT-F1796-00	35- 6
5CA-E2460-00	5- 7	5CA-E4766-10	9- 4	5CA-E5453-00	10-41	5CA-F1161-00	31-27	23Y-F1708-V0	35-12	5CA-F1815-00	18-18
5CA-E2462-00	5-11	5CA-E4799-00	9-16	5CA-E5455-00	10-27	5CA-F1161-00	32-29	5CA-F1731-00	18- 9	5CA-F1815-00	19-18
5CA-E2477-00	5-20	5CA-E4803-00	9-31	5CA-E5461-00	10-19	5CA-F134X-00	23-21	5CA-F1731-00	19- 9	5CA-F1815-00	20-20

部品番號索引

部品番號	項次	部品番號	項次	部品番號	項次	部品番號	項次	部品番號	項次	部品番號	項次
5CA-F1823-00	30-28	3UR-F3181-00	22-13	5CA-F5190-00	25-11	3UH-F7114-00	24-32	5CA-F7497-00-P4	31-23	5CA-F835V-00-P6	34-19
5CA-F1823-00	31-26	3UR-F3181-00	22-27	3UH-F5326-00	27- 4	3UH-F7114-00	30- 2	5CA-F7497-00-P7	31-23	5CA-F835V-00-1V	34-19
5CA-F1823-00	32-28	3UH-F3191-00	22-14	4VP-F533A-00	27-12	3UH-F7114-00	31- 2	5CA-F7497-00-1V	31-23	5CA-F8356-10	33-37
5CA-F1871-00	18-16	3UH-F3191-00	22-28	5CA-F5338-00-1V	27- 1	3UH-F7114-00	32- 2	4TE-F8100-00	14-17	5CA-F8356-10	34-33
5CA-F1871-00	19-16	3UH-F3192-00	22-15	3UH-F5351-00	27- 9	4CW-F7114-00	14-11	5CA-F8257-00	33- 8	5CA-F8356-10	35-35
5CA-F1871-00	20-18	3UH-F3192-00	22-29	5CA-F5355-00	27-10	5CA-F7114-00	14-12	5CA-F8257-00	34- 8	5CA-F836K-00	33-26
5CA-F197J-00	24-14	5CA-F3340-00	22-30	5CA-F580U-00	26- 3	5CA-F7311-00	30- 7	5CA-F8257-00	35- 8	5CA-F836K-00	34-22
3UH-F2141-00	25- 8	5CA-F3346-00	22-31	5CA-F582U-00	26- 1	5CA-F7311-00	31- 7	5CA-F8311-00	33- 1	5CA-F836K-00	35-24
5CA-F2171-10	21- 1	4TE-F3416-00	22-36	3GF-F5852-00	29- 4	5CA-F7311-00	32- 7	5CA-F8311-00	34- 1	5CA-F836L-00	33-14
5CA-F2210-00	21- 9	4VP-F3418-00	22-39	3GF-F5854-00	29- 3	5CA-F7402-00	32-22	5CA-F8311-00	35- 1	5CA-F836L-00	34-14
4X6-F2216-00	10- 4	5CA-F4110-00-33	23- 1	3GF-F5867-00	29- 6	5CA-F7402-10	32-22	5CA-F8313-00	33- 5	5CA-F836L-00	35-14
4X6-F2216-00	21- 8	5CA-F414A-00	23-27	5CA-F5870-00	29- 1	5CA-F7403-00	32-25	5CA-F8313-00	34- 5	5CA-F8365-00	33- 2
5CA-F2220-00	21-10	4JJ-F4170-01	23-20	5CA-F5872-00	29- 9	5CA-F7403-10	32-25	5CA-F8313-00	35- 5	5CA-F8365-00	34- 2
5CA-F3100-10-1V	22- 1	3UH-F4180-02	23-15	5CA-F5875-00	22-40	5CA-F7453-00	30-14	5CA-F832L-00	35-17	5CA-F8365-00	35- 2
5CA-F3102-10-1V	22- 2	5CA-F4311-00	23- 4	5CA-F5876-00	22-42	5CA-F7453-00	31-14	5CA-F832L-10	35-17	5CA-F837U-10	33-31
5CA-F3103-10-1V	22-16	5CA-F4314-00	23-18	5AG-F5919-00	26- 7	5CA-F7453-00	32-14	5CA-F832P-00	35-21	5CA-F837U-10	34-27
5CA-F3110-00	22- 4	3UH-F4376-00	23-24	5AG-F5919-10	26- 8	5CA-F748A-10	30-22	5CA-F832P-10	35-21	5CA-F837U-10	35-29
5CA-F3110-00	22-18	5CA-F4560-00	23-10	5CA-F6110-00	28- 1	5CA-F748A-10	30-25	5CA-F8328-00	33-34	4TE-F8371-00	33-11
4HP-F3111-00	22-11	5CA-F4568-00	23-11	5CA-F6143-00	28-24	5CA-F7481-00	30-11	5CA-F8328-00	34-30	4TE-F8371-00	34-11
4HP-F3111-00	22-25	3UH-F4610-10	23- 2	5CA-F6145-00	28-27	5CA-F7481-00	31-11	5CA-F8328-00	35-32	4TE-F8371-00	35-11
5CA-F3126-10-1V	22- 3	5CA-F4723-00	24-21	4DH-F6199-00	24-37	5CA-F7481-00	32-11	1NT-F834V-00	33-13	5CA-F8391-00	33-17
5CA-F3136-10-1V	22-17	5CA-F473F-00	24- 5	5CA-F6240-00	28- 6	5CA-F7483-00	30-15	1NT-F834V-00	34-13	5CA-F8391-10	33-17
5CA-F3141-00	22- 9	5CA-F473R-00	24-18	5CA-F6241-00	28- 5	5CA-F7483-00	31-15	1NT-F834V-00	35-13	5CA-F8392-00	33-22
5CA-F3141-00	22-23	5CA-F473T-00	24- 7	5CA-F6246-00	28- 4	5CA-F7483-00	32-15	5CA-F834V-00	33-39	5CA-F8392-10	33-22
3UH-F3145-00	22- 5	5CA-F4730-00	24- 1	5CA-F627E-00	28-16	5CA-F7484-00	30-16	5CA-F834V-00	34-35	5CA-F8393-00	33-18
3UH-F3145-00	22-19	5CA-F4738-00	24-24	5CA-F6280-00	28-18	5CA-F7484-00	31-16	5CA-F834V-00	35-37	5CA-F8393-10	33-18
3UR-F3147-00	22-10	5CA-F475M-00	24- 2	5CA-F629T-00	28-19	5CA-F7484-00	32-16	5CA-F834W-00	33-41	5CA-F8394-00	33-23
3UR-F3147-00	22-24	5CA-F4766-00	24-23	5CA-F629T-00	28-22	5CA-F7486-00	30-17	5CA-F834W-00	34-37	5CA-F8394-10	33-23
3UH-F3153-00	22- 6	5CA-F478E-00	24-30	5CA-F6290-00	28-21	5CA-F7486-00	31-17	5CA-F834W-00	35-39	5CA-F840F-00	24-33
3UH-F3153-00	22-20	5CA-F478G-00	24-26	5CA-F6294-00	28-20	5CA-F7486-00	32-17	5CA-F8347-00	33-35	5CA-H1800-00	37- 1
3UR-F3158-00	22-12	4UE-F4780-02	24-28	5CA-F6295-00	28-23	5CA-F7487-00	30-19	5CA-F8347-00	34-31	3KW-H1801-00	37- 3
3UR-F3158-00	22-26	5CA-F4790-00	24- 3	5CA-F6311-00	28- 7	5CA-F7487-00	31-19	5CA-F8347-00	35-33	3UH-H1828-01	37- 5
5CA-F3170-00	22- 8	5CA-F4812-00-4B	24-35	5CA-F6351-11	28-10	5CA-F7487-00	32-19	5CA-F835U-00-P4	34-16	5CA-H183G-00	37- 7
5CA-F3170-00	22-22	5CA-F4812-10	24-35	5CA-F7111-00	30- 1	5CA-F7496-00-P4	31-21	5CA-F835U-00-P6	34-16	3KW-H1861-00	37- 4
3UH-F3173-00	22- 7	5CA-F4842-00	24-40	5CA-F7111-00	31- 1	5CA-F7496-00-P7	31-21	5CA-F835U-00-1V	34-16	4CW-H1940-01	43- 5
3UH-F3173-00	22-21	5CA-F5168-00-1V	25- 1	5CA-F7111-00	32- 1	5CA-F7496-00-1V	31-21	5CA-F835V-00-P4	34-19	5AG-H1960-00	43- 3

部品番號索引

部品番號	項次	部品番號	項次	部品番號	項次	部品番號	項次	部品番號	項次	部品番號	項次
5CA-H1980-00	43-25	5CA-H3509-00	39- 3	5AG-W0057-00	26- 4	5CA-X7496-10-4B 30-21		1UY-14565-00	8- 8	90109-06877	24-15
4CB-H2100-00	43-11	5CA-H3511-00	39- 2	3UH-W1136-10	1- 2	5CA-X7496-20-1V 32-21		4CW-14582-00	8-27	90109-08881	30- 9
5CA-H2129-00	18-12	3KW-H3517-00	39- 4	5CA-W1141-00	2- 2	5CA-X7496-20-4B 32-21		4CW-14589-00	8-26	90109-08881	31- 9
5CA-H2129-00	19-12	5CA-H3550-00	39- 8	5CA-W1441-00	7- 6	5CA-X7497-10-4B 30-24		42H-14714-10	9-23	90109-08881	32- 9
5CA-H2129-00	20-14	5CA-H3550-10	39-10	5CA-W1442-00	7- 8	5CA-X7497-20-1V 32-24		5CA-1490J-00	8-17	90116-08836	10-12
5CA-H2150-00	43-12	5CA-H3551-00	39- 9	5CA-W1512-00	10- 2	5CA-X7497-20-4B 32-24		3UR-14933-00	8-15	90116-08839	10-13
2GE-H2151-00	43-13	5CA-H3551-00	39-11	4TE-W1763-10	12-30	5CA-X8575-00	43-33	22V-14940-00	8-35	90119-05071	43-35
5CA-H2151-00	43-20	5CA-H3912-10	42- 2	5CA-W2341-00	22-44	5CA-Y1310-00	1-16	4CW-14940-00	8-16	90119-06806	40- 5
5CA-H2151-00	43-22	3XG-H3915-00	42- 7	5CA-W2484-00	24-39	5DS-11181-00	1-12	3UH-14945-00	8-21	90119-06821	15- 6
5CA-H2151-00	43-24	4VP-H3922-00	42-17	4CB-W8180-00	37- 2	1WG-12113-01	3- 5	3LD-14958-00	8-32	90119-06821	16- 6
5CA-H2310-00	43- 7	5CA-H3935-00	42- 4	5CA-X2171-00-P6 19- 1		1WG-12116-00	3- 4	4CW-14958-00	8-24	90119-06821	17- 6
4CW-H2370-00	43- 9	5CA-H396K-00	42- 5	5CA-X2171-00-P7 18- 1		3UH-12117-00	3- 7	4CW-14959-00	8-13	90119-06821	30-12
4CW-H2372-00	43-10	5CA-H3962-00	42- 6	5CA-X2171-20-1V 18- 1		1WG-12118-00	3- 6	4CW-14962-00	8-25	90119-06821	30-18
5CA-H2501-01	43-14	5CA-H3975-10	42-14	5CA-X2171-20-4B 20- 1		4TE-12119-00	3- 3	1J7-14968-00	8-11	90119-06821	30-20
5CA-H2501-10	43-16	3GF-H3980-00	42-16	5CA-X2171-30-P4 19- 1		3UH-12151-00	3- 8	4G0-14985-00	8-20	90119-06821	31-12
4TE-H2552-00	43-15	3XG-H3980-01	42-11	5CA-X2171-30-1V 19- 1		22F-12159-00	3- 9	5DS-17641-00	12-16	90119-06821	31-18
4TE-H2552-10	43-17	5CA-H430A-00	40- 4	5CA-X2171-40-1V 20- 1		4HC-12411-00	5- 1	4CW-17653-10	12-10	90119-06821	31-20
5CA-H2588-00	42-12	5CA-H4310-00	40- 1	5CA-X2172-00-P6 19- 5		4CW-14103-00	8- 2	22F-23411-01	22-34	90119-06821	32-12
5CA-H2590-20	43-19	3YB-H4314-00	40- 2	5CA-X2172-00-P7 18- 5		4CW-14105-00	8-12	22F-23412-01	22-33	90119-06821	32-18
5CA-H2590-30	43-21	5CA-H4396-00	40- 3	5CA-X2172-20-1V 18- 5		3KW-14107-20	8-18	5CA-82021-01	43-36	90119-06821	32-20
5CA-H2590-40	43-23	5CA-H4710-00	41- 1	5CA-X2172-20-4B 20- 6		4CW-14115-00	8-29	5CA-82021-20	43-36	90119-06821	33-28
5CA-H2910-10	42- 1	4TE-H4714-00	41- 2	5CA-X2172-30-P4 19- 5		4CW-14117-00	8-28	4BA-82560-00	1-22	90119-06821	34-24
5CA-H3310-00	38- 1	5CA-H4721-00	41- 4	5CA-X2172-30-1V 19- 5		4TF-14141-34	8-36	5CA-82560-01	5-26	90119-06821	35-26
3XG-H3311-00	38- 3	5CA-H4743-00	41- 5	5CA-X2172-40-1V 20- 6		4G0-14142-50	8-37	5CA-82560-10	5-25	90119-08838	24-36
3XG-H3311-00	38- 6	3KW-H5130-00	41-11	3UH-X2533-00	27- 7	3UH-14146-00	8-22	90101-06878	27-11	90149-06834	24- 4
3XG-H3311-00	41- 7	5CA-H5510-00	36- 2	5CA-X283U-00-2X 33-16		137-14153-00	8-14	90105-08121	21-11	90149-08814	26- 2
5CA-H3312-00	38- 2	5CA-H5540-00	43- 1	5CA-X283U-00-3X 33-16		4CW-14171-00	8-30	90105-08825	3-14	90150-05024	33-32
5CA-H3320-00	38- 4	5CA-H5540-10	43- 1	5CA-X283U-10-1V 35-16		537-14186-00	8-19	90105-10036	28- 2	90150-05024	34-28
5CA-H3322-00	38- 5	4KP-H5546-00	43- 2	5CA-X283U-20-4B 35-16		12R-14191-00	8- 4	90105-10836	14- 6	90150-05024	35-30
5CA-H3332-00	41- 3	5CA-H5546-00	43- 2	5CA-X283V-00-2X 33-21		4CW-14197-00	8- 6	90105-10850	26-10	90153-06803	1- 6
5CA-H3350-00	43-29	5CA-H5550-00	36- 1	5CA-X283V-00-3X 33-21		3G2-14231-17	8-38	90109-06001	24-43	90154-06807	15- 3
4KP-H3371-01	43-31	53X-H5753-00	43-34	5CA-X283V-10-1V 35-20		620-14231-23	8-34	90109-063F1	24-19	90154-06807	16- 3
3XY-H3390-01	43-30	5CA-W0041-00	29- 2	5CA-X283V-20-4B 35-20		4CW-14243-00	8-10	90109-06577	42-18	90154-06807	17- 3
5CA-H3500-00	39- 1	5AG-W0045-00	26- 9	5CA-X2834-00-4B 34-29		26H-14275-00	8-33	90109-06876	15- 4	90159-03102	39- 6
5CA-H3500-21	39- 1	5AG-W0047-00	26- 5	5CA-X2834-00-4B 35-31		3XV-14396-10	8- 5	90109-06876	16- 4	90159-05083	33-30
5CA-H3500-30	39- 1	5AG-W0048-00	26- 6	5CA-X2834-10	33-33	4CW-14504-00	8- 7	90109-06876	17- 4	90159-05083	34-26

部品番號索引

部品番號	項次	部品番號	項次	部品番號	項次	部品番號	項次	部品番號	項次	部品番號	項次
90159-05083	35-28	90183-05807	20- 4	90201-163J6	12-14	90430-06166	5- 4	90467-09006	23-26	90506-20841	32- 8
90159-05831	28-28	90183-05807	20-10	90201-164J0	12-15	90430-08816	10-15	90467-10008	4-14	90506-32834	30- 6
90159-06150	30-32	90183-05807	20-13	90201-175F6	11-16	90430-08816	10-60	90467-10008	7-27	90506-32834	31- 6
90159-06150	31-30	90183-05807	24-12	90201-220J8	27-13	90445-091K5	23- 7	90467-10041	23- 5	90506-32834	32- 6
90159-06150	32-32	90183-05807	24-20	90202-15804	30- 3	90445-09104	18-20	90467-10857	5-24	90508-40850	11-14
90159-06813	18-17	90183-05807	28-26	90202-15804	31- 3	90445-09104	19-20	90467-12052	7-15	91A10-07048	23-29
90159-06813	19-17	90183-05807	30-13	90202-15804	32- 3	90445-09104	20-22	90467-12052	10- 7	91317-06010	5- 3
90159-06813	20-19	90183-05807	31-13	90202-26142	22-38	90445-098B1	18-19	90467-13813	7-16	91317-06010	9- 8
90159-06813	23-22	90183-05807	32-13	90206-10808	24-16	90445-098B1	19-19	90467-16829	9-37	91317-06012	3-22
90159-06813	33-40	90183-05807	33- 4	90208-12050	12-12	90445-098B1	20-21	90467-16829	9-43	91317-06014	3-20
90159-06813	34-36	90183-05807	33-10	90240-05047	24- 8	90445-098B2	23-13	90467-20810	5-17	91317-06020	24-41
90159-06813	35-38	90183-05807	33-20	90249-12008	28-13	90445-098B3	23-25	90467-20810	5-22	91317-06025	1-15
90170-05302	3-10	90183-05807	33-25	90280-03017	2-11	90445-11865	23-23	90467-21860	5-16	91317-06025	1-19
90170-12181	36- 7	90183-05807	34- 4	90338-09012	29- 7	90446-13805	7-13	90468-08812	9-30	91317-06025	4- 9
90170-12338	12-18	90183-05807	34-10	90338-11820	7-14	90450-25826	5-19	90468-12007	24-10	91317-06025	29- 8
90170-36279	12-28	90183-05807	34-18	90380-17806	11-17	90460-56287	7-21	90468-18121	24-27	91317-06070	9-28
90176-06805	33- 9	90183-05807	34-21	90387-062M9	15-13	90461-15801	23-16	90480-01141	14-16	91317-08030	11-19
90176-06805	34- 9	90183-05807	35- 4	90387-062M9	16-13	90464-08020	10-49	90480-01884	24- 6	91380-06012	9-17
90176-06805	35- 9	90183-05807	35-10	90387-062M9	17-13	90464-12812	43-26	90480-12497	10-54	92907-05600	42-13
90176-08816	1-11	90183-05807	35-19	90387-068F9	10-53	90464-15840	14-14	90480-12887	9-10	92907-06200	9- 5
90179-05849	33-29	90183-05807	35-23	90387-068W4	41-14	90464-15840	43-28	90480-14889	9-13	92907-06600	9-19
90179-05849	34-25	90183-05807	41- 9	90387-068X3	9-12	90464-23811	23-30	90480-15520	9-25	92907-12100	36- 6
90179-05849	35-27	90185-08818	30-10	90387-10800	30- 4	90464-23811	28- 9	90480-18276	14-15	92907-12600	36- 5
90179-06411	28-14	90185-08818	31-10	90387-10800	31- 4	90464-23811	28-11	90480-23885	30-33	93101-19172	10-43
90179-06850	9-20	90185-08818	32-10	90387-10800	32- 4	90464-23811	43-27	90480-23885	31-31	93101-21170	12- 7
90179-14427	12- 5	90185-14124	27-14	90387-125J1	25- 9	90465-13275	28-12	90480-23885	32-33	93102-17853	25- 5
90179-25615	22-37	90201-06050	24-42	90387-128V2	25- 2	90467-08003	23- 6	90480-30167	10-56	93102-19477	10-44
90183-05807	15- 7	90201-064H0	7-17	90387-153N8	21- 7	90467-08003	23- 8	90501-10312	42-20	93102-22800	12- 3
90183-05807	16- 7	90201-06557	9-27	90387-15423	21- 5	90467-08092	9-39	90501-10826	5-21	93102-22843	10-10
90183-05807	17- 7	90201-067L0	9-14	90387-168D2	12-13	90467-09006	7-26	90501-10827	5-18	93102-32894	13- 9
90183-05807	18- 3	90201-077F5	6- 5	90387-168S2	11-11	90467-09006	18-21	90501-16829	6-10	93103-10168	4- 3
90183-05807	18- 8	90201-08609	1-10	90401-10805	29-10	90467-09006	19-21	90501-16869	28-15	93104-41119	12-21
90183-05807	18-11	90201-10118	29-11	90430-06014	1- 7	90467-09006	20-23	90501-452J8	12-24	93106-26823	21- 4
90183-05807	19- 3	90201-105A2	21-13	90430-06014	1-21	90467-09006	23- 9	90506-16447	27- 8	93109-28811	21- 3
90183-05807	19- 8	90201-108A3	11- 4	90430-06014	10-47	90467-09006	23-14	90506-20841	30- 8	93210-058H0	24- 9
90183-05807	19-11	90201-158B8	13- 2	90430-06166	4-10	90467-09006	23-19	90506-20841	31- 8	93210-07890	27- 6

部品番號索引

部品番號	項次	部品番號	項次	部品番號	項次	部品番號	項次	部品番號	項次	部品番號	項次
93210-09884	3-27	94113-12800	27- 3	95807-06014	33-42	97707-50016	18- 4	97707-50016	34-32	98907-06020	10-32
93210-14801	5-27	94591-48094	3-15	95807-06014	34-38	97707-50016	18- 7	97707-50016	35- 3	98980-06020	9- 3
93210-14805	10-17	94700-00826	1-18	95807-06014	35-40	97707-50016	18-10	97707-50016	35-15	99001-05600	6- 6
93210-15862	3-23	95027-06010	1-20	95807-06014	41-13	97707-50016	18-13	97707-50016	35-18	99009-17400	11-15
93210-26668	37- 6	95027-06010	7-24	95807-06016	9-41	97707-50016	18-15	97707-50016	35-22	99009-17400	14- 9
93210-268H1	10-58	95027-06010	23-12	95807-06016	24-29	97707-50016	19- 4	97707-50016	35-25	99009-25400	13- 6
93210-30611	7- 2	95027-06016	5- 9	95817-08016	10-14	97707-50016	19- 7	97707-50016	35-34	99530-08012	10-45
93210-35879	6-11	95027-06016	28-17	95817-08016	10-59	97707-50016	19-10	97707-50016	38- 7	99530-10114	1-13
93210-438H2	12-22	95027-06020	5- 5	95817-08020	9-21	97707-50016	19-13	97707-50016	39- 7	99530-10114	1-14
93210-448C2	1- 9	95027-06020	7- 3	95817-08030	9-22	97707-50016	19-15	97707-50016	40- 6	99530-10114	10- 8
93210-63881	4- 7	95027-06020	10-46	95827-06012	3-26	97707-50016	20- 5	97707-50016	41- 8	99530-10114	10-20
93211-077A5	10-42	95027-06030	10-21	95827-06012	9-34	97707-50016	20- 9	98502-04006	8- 9	99530-10114	10-24
93306-003Y4	11- 8	95027-06035	10-25	95827-08045	21- 2	97707-50016	20-12	98507-05010	24-31		
93306-201Y2	25- 3	95027-06080	10- 9	95827-10025	14-10	97707-50016	20-15	98507-05010	28- 8		
93306-203Y0	12-29	95307-06700	43- 6	95827-10035	30- 5	97707-50016	20-17	98507-05012	9-32		
93306-20427	12- 2	95607-05100	42- 8	95827-10035	31- 5	97707-50016	24-13	98507-05020	42- 9		
93306-272Y0	13- 8	95607-06100	42-19	95827-10035	32- 5	97707-50016	24-22	98507-05025	42-15		
93306-30101	13-10	95607-10200	14- 4	97007-06012	5-12	97707-50016	28-25	98507-05030	42-10		
93306-301Y3	25- 4	95607-10200	14- 7	97507-06525	37- 8	97707-50016	28-29	98507-06010	43-32		
93306-302X1	21- 6	95607-10200	28- 3	97602-04114	8- 3	97707-50016	30-23	98507-06012	4-12		
93306-303Y8	13- 7	95607-12200	25-10	97607-03108	42- 3	97707-50016	30-26	98507-06012	11- 6		
93306-30536	2- 7	95707-05500	41-12	97607-04312	39- 5	97707-50016	31-22	98507-06012	43-18		
93310-6290C	2- 4	95707-06500	24-25	97607-05212	23-17	97707-50016	31-24	98507-06014	15-12		
93311-315Y2	13- 3	95707-06500	24-34	97607-05225	43- 4	97707-50016	32-23	98507-06014	16-12		
93315-110Y6	11- 2	95707-08500	24-17	97607-06216	36- 3	97707-50016	32-26	98507-06014	17-12		
93399-99940	22-32	95707-10500	21-12	97607-06225	7-12	97707-50016	33- 3	98507-06018	43- 8		
93440-10153	1- 3	95707-10500	27- 5	97607-06225	7-22	97707-50016	33-15	98507-06020	7-18		
93450-16068	2-14	95807-06012	22-41	97607-06230	36- 4	97707-50016	33-19	98507-06020	10-55		
93450-35015	11- 9	95807-06012	23- 3	97707-04616	41- 6	97707-50016	33-24	98507-06025	4-15		
93503-16003	22-35	95807-06012	30-30	97707-40512	33- 7	97707-50016	33-27	98507-06050	4-16		
93602-13832	6- 4	95807-06012	31-28	97707-40512	34- 7	97707-50016	33-36	98702-04008	8-23		
93603-12833	6- 3	95807-06012	32-30	97707-40512	35- 7	97707-50016	34- 3	98707-04012	29- 5		
93604-10011	4- 8	95807-06012	33-38	97707-50016	9-42	97707-50016	34-15	98707-06020	6- 7		
93900-00802	25- 6	95807-06012	34-34	97707-50016	15- 9	97707-50016	34-17	98907-06010	10-28		
93900-00802	27- 2	95807-06012	35-36	97707-50016	16- 9	97707-50016	34-20	98907-06010	24-11		
94112-12800	25- 7	95807-06014	22-43	97707-50016	17- 9	97707-50016	34-23	98907-06020	9- 6		

BEST CHOICE

YAMAHA

管理番號 105CA-414C1

台灣山葉機車工業股份有限公司 部品部

2000.08.3.0 X 1 30